



















































switches
OVERALL SOLUTION EXPERT























INDEX

Item	Type	Series	Features	Dimensions(mm)			Earth Terminal	Package	Page	
				W	D	H				
Tact Switch < A >	Surface Mount	TVAU25		Miniature	3	2.1	0.5/0.7	—	10Kpcs/Reel	2
		TVAU19-H		Miniature	3	2.6	0.65	—	10Kpcs/Reel	3
		TVAU19-N		Miniature	3	2.6	0.50	—	10Kpcs/Reel	3
		THAF01		Horizontal	3.5	3	1.4	—	3Kpcs/Reel	4
		TVAF02		Miniature	3.5	3	1.8	—	3Kpcs/Reel	4
		TVAF03		Miniature	3.35	3.35	1.5/2.0		4Kpcs/Reel	5
		TVAF17		Miniature	3.35	3.35	0.85		5Kpcs/Reel	6
		TVAF18		Miniature	3.1	3.1	0.75	—	5Kpcs/Reel	6
		THAM04		Horizontal	4.6	2.3	1.8	—	3Kpcs/Reel	7
		THAM05		Horizontal	4.6	2.3	1.8	—	3Kpcs/Reel	7
		THAM15		Horizontal	4.6	2.3	2.65	—	3Kpcs/Reel	8
		THAM16		Dust-Poof	4.6	2.3	1.8	—	3Kpcs/Reel	8
		TVAF06		Miniature	3.9	2.9	2.0	—	3Kpcs/Reel	9
		TVAU07		Miniature	3.9	2.9	2.0	—	3Kpcs/Reel	9
		THAU08		Horizontal	3.9	2.9	1.5	—	3Kpcs/Reel	10
		THAF09		Horizontal	3.9	2.9	1.5	—	3Kpcs/Reel	10
		TVAU10		Miniature	4.2	3.2	2.5	—	3Kpcs/Reel	11
		TVAF11		Miniature	4.2	3.2	2.5	—	3Kpcs/Reel	11
		THAM12		Horizontal	4.5	2.56	3.3	—	2Kpcs/Reel	12
		THAM16		Horizontal	5.7	2.5	3.5	—	2Kpcs/Reel	12
		THAU13		Horizontal	4.7	3.5	1.6	—	3Kpcs/Reel	13
		THAF14		Horizontal	4.7	3.5	1.6	—	3Kpcs/Reel	13
		TVAU22		Miniature	3.7	3.7	0.35	—	10Kpcs/Reel	14
		TVAF28		Miniature	3.5	3.0	1.7	—	3Kpcs/Reel	15
		TVAU29		Miniature	3.5	3.0	1.7	—	3 Kpcs/Reel	15
		TVAU23		Miniature	4.7	3.6	2.5	—	3Kpcs/Reel	16
TVAF24		Miniature	4.7	3.6	2.5	—	3Kpcs/Reel	16		
Item	Type	Series	Features	Dimensions(mm)			Earth Terminal	Package	Page	
				W	D	H				
Tact Switch < B >	Surface Mount	THBM02		Horizontal	7.0	2.5	3.5	—	2Kpcs/Reel	17
		THBM03		Horizontal	7.0	2.5	3.5	—	2Kpcs/Reel	17
		THBM05		Horizontal	6.1	4.0	1.8	—	2Kpcs/Reel	19

INDEX

Item	Type	Series	Features	Dimensions(mm)			Earth Terminal	Package	Page	
				W	D	H				
Tact Switch < B >	Surface Mount	TVBR14		Vertical	6.0	3.5	4.3/5.0	—	1.5Kpcs/Reel	20
		TVBF09		Vertical	6.0	3.5	4.3/5.0	—	1.5Kpcs/Reel	21
		TVBU10		Vertical	6.0	3.5	4.3/5.0	—	1.5Kpcs/Reel	21
		TVBM11		Vertical	6.0	3.5	4.3/5.0	—	1.5Kpcs/Reel	22
		TVBM17		Dust-proof	6.1	3.7	2.5	●	3Kpcs/Reel	24
		TVBF18		Dust-proof	6.1	3.7	2.5	●	3Kpcs/Reel	24
		TVBU19		Dust-proof	6.1	3.7	2.5	●	3Kpcs/Reel	24
		TVBM20		Vertical	6.1	3.7	2.5	—	3Kpcs/Reel	25
		TVBP21		Vertical	6.0	3.5	2.5	—	3Kpcs/Reel	25
		TVBF22		Normal Closed	6.0	3.8	2.6	—	3Kpcs/Reel	26
	Snap-in	THBP04		Horizontal	6.0	3.5	3.5	—	1Kpcs/Bulk	18
		THBP07		Horizontal	7.3	6.0	4.3	—	1Kpcs/Bulk	18
		TVBP06		Vertical	6.0	3.5	4.3/5.0	—	1Kpcs/Bulk	20
		TVBJ12		Vertical	6.0	3.5	4.3/5.0	—	1Kpcs/Bulk	20
		TVBT16		Vertical	6.0	3.5	4.3/5.0	—	1Kpcs/Box	23
Item	Type	Series	Features	Dimensions(mm)			Earth Terminal	Package	Page	
				W	D	H				
Tact Switch < C >	Surface Mount	TVCM01		Vertical	4.5	4.5	X	—	2Kpcs/Reel(H:3.8/4.3/5.0) 800pcs/Reel(H:6.0/7.0/8.0)	27
		TVCM04		Vertical	4.5	4.3	1.6	—	4Kpcs/Reel	28
		TVCM09		Low-Profile	4.5	4.5	0.55	—	5Kpcs/Reel	29
		TVCU11		Low-Profile	5.2	5.2	0.9	●	4Kpcs/Reel	30
		TVCU12		Low-Profile	5.2	5.2	0.8	—	5Kpcs/Reel	30
		TVCU13		Low-Profile	4.8	4.8	0.55	—	5Kpcs/Reel	31
		TVCM15		Low-Profile	5.2	5.2	1.0	—	4Kpcs/Reel	32
		TVCM16		Dust-proof	5.2	5.2	X	—	4Kpcs/Reel	33
		TVCM17		Dust-proof	5.2	5.2	X	—	4Kpcs/Reel	33
		TVCU18		Dust-proof	5.2	5.2	X	●	4Kpcs/Reel	34
		TVCF19		Dust-proof	5.2	5.2	X	●	4Kpcs/Reel	34





























INDEX

Item	Type	Series	Features	Dimensions(mm)			Earth Terminal	Package	Page	
				W	D	H				
Tact Switch < C >	Snap-in	TVCP02		Vertical	4.5	4.5	X	—	1Kpcs/Bulk	27
		THCP03		Horizontal	4.5	4.5	X	●	1Kpcs/Bulk	27
Item	Type	Series	Features	Dimensions(mm)			Earth Terminal	Package	Page	
				W	D	H				
Tact Switch < D >	Surface Mount	THDM03		Horizontal	6.0	6.0	7.4	●	500pcs/Reel	36
		TVDM04		Vertical	6.0	6.0	X	●	1Kpcs/Reel(H:4.3/6.0) 700pcs/Reel(H:6.5/8.0) 500pcs/Reel(H:8.5/10.0)	37
		TVDM04-G73		Vertical	6.0	6.0	7.3	●	700pcs/Reel	37
		TVDM25		Vertical	6.0	6.0	X	●	1Kpcs/Reel(H:4.3/6.0) 700pcs/Reel(H:6.5/8.0) 500pcs/Reel(H:8.5/10.0)	37
		THDM13		Horizontal	7.1	5.0	7.5	●	500pcs/Reel	41
		TVDU21		Long-Travel	6.0	6.0	5.0	—	1Kpcs/Reel	46
	Snap-in	TVDP01		Vertical	6.0	6.0	X	●	1Kpcs/Bulk	35
		TVDP02		Vertical	6.0	6.0	X	●	1Kpcs/Bulk	35
		TVDP01-G73		Vertical	6.0	6.0	7.3	●	1Kpcs/Bulk	35
		TVDJ06		Vertical	6.0	6.0	X	●	1Kpcs/Bulk	38
		THDP07		Horizontal	6.0	6.0	X	●	1Kpcs/Bulk	38
		THDP19		Horizontal	6.0	6.0	X	●	1Kpcs/Bulk	38
		THDP08		Horizontal	7.5	6.55	7.1	—	1Kpcs/Bulk	39
		THDP09		Horizontal	7.5	6.55	7.1	—	1Kpcs/Bulk	39
		THDP10		Horizontal	7.5	6.55	7.1	—	1Kpcs/Bulk	39
		THDP11		Horizontal	7.5	6.55	7.1	—	1Kpcs/Bulk	40
		THDP12		Horizontal	6.2	6.2	11.25	—	500pcs/Bulk	40
		THDT14		Horizontal	7.4	9.25	7.1	—	700pcs/Box	42
		TVDT17		Vertical	6.0	6.0	X	—	2kpcs/Box	42
		TVDT18		Circle	φ6		4.3/5.0	—	1kpcs/Box	44
		THDP24		Two-Key	7.3	8.0	9.65	—	500pcs/Bulk	45





























INDEX

Item	Type	Series	Features	Dimensions(mm)			Earth Terminal	Package	Page	
				W	D	H				
Tact Switch < E >	Surface Mount	TVEU01		Vertical	6.2	6.2	2.0/2.5/3.1		1.5Kpcs/Reel	47
		TVEF02		Vertical	6.2	6.2	2.0/2.5/3.1		1.5Kpcs/Reel	47
		TVEM04		Dust-proof	6.2	6.2	3.1/5.0		1.5Kpcs/Reel	48
		TVEM05-E		Vertical	6.2	6.2	2.5/3.1/3.4		1.5Kpcs/Reel	49
		TVEJ10		Middle-Travel	6.2	6.2	3.5	—	1.5Kpcs/Reel	51
		TVEM11		Middle-Travel	6.2	6.2	3.5	—	1.5Kpcs/Reel	51
	Snap-in	TVEP07		Vertical	6.2	6.2	2.5/3.1/3.4		1Kpcs/Bulk	50
		TVEJ08		Vertical	6.2	6.2	2.5/3.1/3.4		1Kpcs/Bulk	50
Item	Type	Series	Features	Dimensions(mm)			Earth Terminal	Package	Page	
				W	D	H				
Tact Switch < G >	Surface Mount	TVGM03		Vertical	12.0	12.0	X		900pcs/Reel(H:4.3/5.0) 600pcs/Reel(H:6.0) 500pcs/Reel(H:7.0/7.3)	54
	Snap-in	TVGP01		Vertical	12.0	12.0	X		500pcs/Bulk	53
		TVGP01-□G73		Vertical	12.0	12.0	7.3		500pcs/Bulk	53
		TVGP01-A		Vertical	12.0	12.0	X		500pcs/Bulk	53
Item	Type	Series	Features	Dimensions(mm)			Earth Terminal	Package	Page	
				W	D	H				
Tact Switch < J >	Surface Mount	TVEJ12-□031		Washable	6.2	6.2	3.1	—	1.5Kpcs/Reel	52
		TVEJ12-□052		Washable	6.2	6.2	5.0	—	1.5Kpcs/Reel	52
		TVEJ12-□023		Washable	6.2	6.2	2.3	—	1.5Kpcs/Reel	52
		TVJM17		Washable	6.2	6.2	X	—	1Kpcs/Reel(H:4.3/6.0) 700pcs/Reel(H:6.5/8.0) 500pcs/Reel(H:8.5/10.0)	56
	Snap-in	TVJP13		Washable	6.2	6.2	X	—	1Kpcs/Bulk	55
		TVJP16		Washable	6.2	6.2	8.0~13.0	—	500pcs/Bulk	55
		TVJP14		Washable	8.0	8.0	6.5~13.0	—	1Kpcs/Bulk	57
		TVJP12-N		Washable	100	100	33.6	—	200pcs/Bulk	58
		TVJP12-E		Washable	100	100	33.6		200pcs/Bulk	58
		TVJP11		Washable	100	100	13/23.2	—	500pcs/Bulk	59
TVJP09		Washable	100	100	5.0	—	500pcs/Bulk	60		

















































INDEX

Item	Type	Series	Features	Dimensions(mm)			Earth Terminal	Package	Page
				W	D	H			
Tact Switch < J >	Snap-in	TVJP07	 Washable	φ10		13.0	—	1Kpcs/Box	61
		TVJP08	 Washable	8.0	8.0	13.0	—	1Kpcs/Box	61
		TVJP15	 Washable	12.0	12.0	6.5~12.0	—	500pcs/Bulk	62
Item	Type	Series	Features	Dimensions(mm)			Earth Terminal	Package	Page
				W	D	H			
Multi-Function Switch < H >	Multiway	TMHF07	 Double Action	6.5	6.2	2.0/3.8	—	1Kpcs/Reel	64
		TMHU12	 4-direction & center-push	6.5	6.1	5.0	●	1Kpcs/Reel	65
		TMHU13	 4-direction & center-push	7.5	7.5	5.0	●	1Kpcs/Reel	66
		TMHM14	 4-direction & center-push	10.4	10.0	5.0	●	1Kpcs/Reel	67
		TMHM16	 4-direction & center-push	10.7	10.0	6.50	●	650pcs/Reel	68
		TMHU26	 Push&Lever	11.8	11.7	2.5	—	1Kpcs/Reel	69
		TMHU27	 Push&Lever	12.0	11.8	2.5	—	1Kpcs/Reel	69
		TMHU28	 Push&Lever	11.8	11.3	3.0	—	1Kpcs/Reel	70
		TMHU29	 Push&Lever	11.8	11.4	3.0	—	1Kpcs/Reel	70
		TMHU32	 Push&Lever	9.5	8.15	2.2	—	1.5Kpcs/Reel	71
		TMHU33	 Push&Lever	9.5	8.8	2.2	—	1.5Kpcs/Reel	71
Item	Type	Series	Features	Dimensions(mm)			Self-Lock	Package	Page
				W	D	H			
Light Switch < I >	Surface Mount	LS616	 illuminated	6.0	6.0	7.2	—	100pcs/Tray	79
		LS617	 illuminated	7.5	7.5	11.50	—	100pcs/Tray	80
	Snap-in	LS601	 illuminated	6.0	6.0	7.0/7.2	—	200pcs/Tray	73
		LS602	 illuminated	7.5	7.5	8.2	—	150pcs/Tray	73
		LS603	 illuminated	7.5	7.5	8.2	—	150pcs/Tray	74
		LS604	 illuminated	10.0	10.0	8.5	—	150pcs/Tray	74
		LS605	 illuminated	6.0	6.0	8.5	—	200pcs/Tray	75
		LS606	 illuminated	7.5	7.5	9.6	—	150pcs/Tray	75
		LS609	 illuminated	10	10.0	9.7	—	150pcs/Tray	76
		LS610	 illuminated	φ10.0		9.4	—	150pcs/Tray	76
		LS611	 illuminated	6.0	6.0	7.0	—	200pcs/Tray	77
		LS613	 illuminated	10.0	10.0	10.0	—	150pcs/Tray	78
		LS614	 illuminated	10.0	10.0	10.0	—	150pcs/Tray	78
		LS615	 illuminated	10.0	10.0	8.15	—	100pcs/Tray	79























































INDEX

Item	Type	Series	Features	Dimensions(mm)			Earth Terminal	Package	Page	
				W	D	H				
Light Switch < I >	Snap-in	LS618		illuminated	6.0	6.0	8.9	—	100pcs/Tray	80
		LS619		illuminated	6.0	6.0	9.1	—	100pcs/Tray	81
		LS620		illuminated	6.0	6.0	8.9	—	100pcs/Tray	81
		LS621		illuminated	6.0	6.0	8.9	—	100pcs/Tray	82
		LS622		illuminated	7.5	7.5	9.75	—	100pcs/Tray	82
		LS623		illuminated	9.9	9.9	8.8	—	100pcs/Tray	83
		LS624		illuminated	φ10.0		9.65	—	100pcs/Tray	83
		LS625		illuminated	9.95	9.95	9.60	—	100pcs/Tray	84
		LS626		illuminated	9.95	9.95	9.60	—	100pcs/Tray	84
		LS627		illuminated	12.5	12.5	9.85	—	100pcs/Tray	85
		LS628		illuminated	12.5	12.5	9.85	—	100pcs/Tray	85
		LS629		illuminated	8.3	8.6	10.7	—	100pcs/Tray	86
		LS630		illuminated	8.3	8.6	10.7	—	100pcs/Tray	86
		LS631		illuminated	8.3	8.6	10.7	—	100pcs/Tray	87
		LS8501		illuminated	8.5	7.5	10.1	●	100pcs/Tray	88
		LS8502		illuminated	8.5	7.5	11.5	●	100pcs/Tray	88
		LS8503		illuminated	10.0	10.0	12.5	●	100pcs/Tray	89
		LS8504		illuminated	8.9	9.0	12.85	●	100pcs/Tray	89
		LS8505		illuminated	8.9	9.0	12.85	●	100pcs/Tray	90
		LS8506		illuminated	12.6	12.6	12.75	●	100pcs/Tray	90
		LS8507		illuminated	φ12.6		12.70	●	100pcs/Tray	91
		LS8508		illuminated	12.6	12.6	12.75	●	100pcs/Tray	91
		LS8509		illuminated	φ12.6		12.75	●	100pcs/Tray	92
		LS8510		illuminated	φ12.6		12.75	●	100pcs/Tray	92
		LS8511		illuminated	8.5	8.5	11.2	—	200pcs/Tray	93
		LS8512		illuminated	8.5	8.5	14.0	—	100pcs/Tray	93
		LS1001		illuminated	10.0	10.0	10.7	—	100pcs/Tray	94
		LS1002		illuminated	10.0	10.0	10.7	—	100pcs/Tray	94
		LS1003		illuminated	10.0	10.0	15.2	—	100pcs/Tray	95

INDEX

Item	Type	Series	Features	Dimensions(mm)			Self-Lock	Package	Page	
				W	D	H				
Light Switch < >	Snap-in	LS1004		illuminated	15.1	15.1	12.0		50pcs/Tray	95
		LS1005		illuminated	15.1	15.1	12.0		50pcs/Tray	96
		LS1006		illuminated	10.0	10.0	15.3	—	100pcs/Tray	96
		LS1201		illuminated	12.0	12.0	7.3	—	100pcs/Tray	97
		LS1202		illuminated	12.0	12.0	8.0	—	100pcs/Tray	98
Item	Type	Series	Features	Dimensions(mm)			No-Lock	Package	Page	
				W	D	H				
Push Switch	Surface Mount	PS8004		Self-Lock	8.0	8.0	13.6		1Kpcs/Bulk	102
		PS8007		Self-Lock	8.0	8.0	13.6		1Kpcs/Bulk	102
	Snap-in	PS5801		Self-Lock	5.8	5.8	10.0		1Kpcs/Bulk	100
		PS5804		Self-Lock	5.8	5.8	10.0		1Kpcs/Bulk	100
		PS5807		Self-Lock	5.8	5.8	7.35		1Kpcs/Bulk	100
		PS7001		Self-Lock	7.0	7.0	12.7		1Kpcs/Bulk	101
		PS7004		Self-Lock	7.0	7.0	9.7		1Kpcs/Bulk	101
		PS8001		Self-Lock	8.0	8.0	13.6		1Kpcs/Bulk	102
		PS84501		Self-Lock	8.45	8.45	14.0		1Kpcs/Bulk	103
		PS84504		Self-Lock	8.45	8.45	13.95		1Kpcs/Bulk	103
		PS84507		Self-Lock	8.45	8.45	14.0		1Kpcs/Bulk	103
		PS8501		Self-Lock	8.5	8.5	13.95		1Kpcs/Bulk	104
		PS8504		Self-Lock	8.5	8.5	14.0		1Kpcs/Bulk	104
		PS8507		Self-Lock	8.5	8.5	14.15		1Kpcs/Bulk	104
		PS8510		Self-Lock	8.5	8.5	14.20		1Kpcs/Bulk	105
		PS8513		Self-Lock	8.5	8.5	13.95		1Kpcs/Bulk	105
		PS8516		Self-Lock	8.5	8.5	14.20		1Kpcs/Bulk	105
		PV8519		Self-Lock	13.0	8.5	14.20		1Kpcs/Bulk	106
		PS12301		Self-Lock	12.3	11.0	19.0		1Kpcs/Bulk	107
		PS12303		Self-Lock	12.3	11.0	19.0		1Kpcs/Bulk	107
		PS12305		Self-Lock	12.3	11.0	24.4		1Kpcs/Bulk	107

INDEX

Item	Type	Series	Features	Dimensions(mm)			Halogen-Free	Package	Page	
				W	D	H				
Rotary Coded Switch	Surface Mount	R7M2		Rotary	7.4	7.3	0/3.0		62pcs/Tube	114
		R7M3		Rotary	7.2	7.2	0/3.0		63pcs/Tube	115
		RH-16		Rotary	10.0	10.0	6.85		50pcs/Tube	109
	Snap-in	RH-10		Rotary	10.0	10.0	6.85		50pcs/Tube	109
		RHL-16		Rotary	10.0	10.0	13.75		50pcs/Tube	110
		RHL-10		Rotary	10.0	10.0	13.75		50pcs/Tube	110
		RR3-4		Rotary	9.8	6.74	9.9		48pcs/Tube	111
		RH2		Rotary	9.8	6.64	9.9		48pcs/Tube	112
		RM3		Rotary	9.8	9.9	4.5		48pcs/Tube	113
		RR4		Rotary	9.8	9.8	4.5		48pcs/Tube	113
		R7S2		Rotary	7.4	7.3	0/3.0		62pcs/Tube	114
		R7R4		Rotary	7.2	7.9	7.77		60pcs/Tube	116
		R7H3		Rotary	7.2	7.2	0/3.0		63pcs/Tube	116
		Item	Type	Series	Features	Dimensions(mm)			Top Tape Sealed	Package
W	D					H				
Dip Switch	Surface & Snap-in	DHMF		Half-Pitch	X	4.5	1.5		Details See Behind	118
		DHM		Half-Pitch	X	4.5	1.5			118
		DEM		End Stackable	X	6.0	3.4			119
		DEH		End Stackable	X	6.0	2.8			120
		DAH(S)		Auto Inserting	X	6.2	3.6			121
		DAM		Auto Inserting	X	6.2	3.0			122
		DAF		Auto Inserting	X	6.2	3.0			123
		DPS		New Piano	X	6.0	5.0			124
		DPM		New Piano	X	6.0	5.0			125
		PEH		End Stackable Piano	X	6.0	5.0			126
		PEM		End Stackable Piano	X	6.0	5.0			127
		DS		Silde	X	9.9	7.1			128
		DP		Piano	X	10.8	10.3			129
		DR		Right Angle	X	9.9	9.9			130

01

TACT SWITCH SERIES

Features:

- Microminiature, light operating.
- Good feeling and long life.
- Snap-in type, can be mounted directly on P.C. Board and good for electrostatic discharge.
- It has a lot of choices for button shape, height and it is easily to install all kind of product.

Applications:

They can operate all types of electronic equipment such as the telephone, PDA, DVD, digital camera, audio equipment, instrument and meter equipment, autoimmunization equipments control etc.

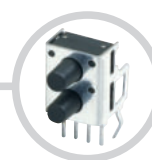
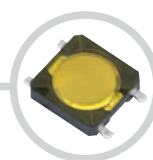
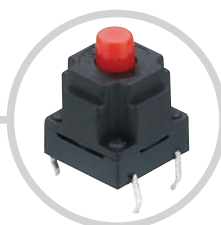

MINI SERIES

2.0x3.0 Miniature Type Vertical Push Tact Switch

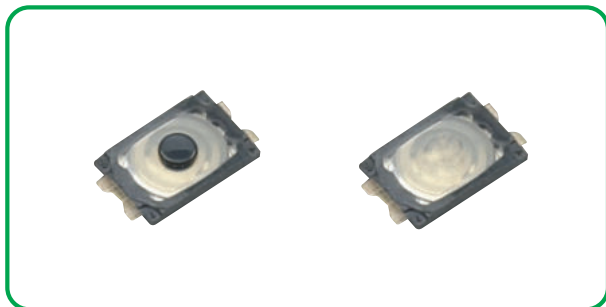

HOW TO ORDER

T V A U 2 5

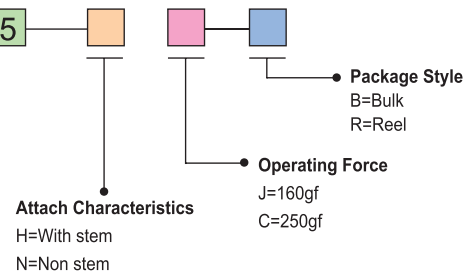

Specification

Items		Standard
Operating temperature range		-30°C to +85°C
Electrical performance	Rating	20mA. 15V DC
	Insulation resistance	50MΩ min. 100V DC
	Dielectric strength	250V AC for 1 min.
	Contact resistance	500mΩ max.
Durability	Lifetime	J:100,000 Cycles C:50,000 Cycles
Mechanical performance	Operating force	J:160gf C:250gf
	Travel	0.15 ± 0.05mm

Diagram

No.	Dimensions	Circuit Diagram
		Pad Layout
1	<p>● TVAU25</p>	

MINI SERIES

2.7x3.0 Miniature Type Vertical Push Tact Switch



TACT SWITCH

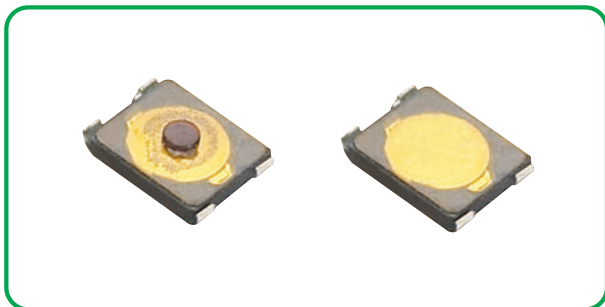

HOW TO ORDER

T V A U 1 9

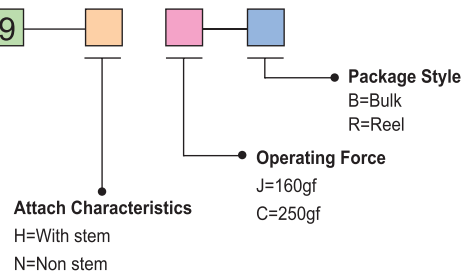

Specification

Items		Standard
Operating temperature range		-30°C to +85°C
Electrical performance	Rating	20mA. 12V DC
	Insulation resistance	50MΩ min. 100V DC
	Dielectric strength	250V AC for 1 min.
	Contact resistance	100mΩ max.
Durability	Lifetime	J:100,000 Cycles C:50,000 Cycles
Mechanical performance	Operating force	J:160gf C:250gf
	Travel	0.15 ± 0.05mm

Diagram

No.	Dimensions	Circuit Diagram Pad Layout
1	<p>● TVAU19-H</p>	
2	<p>● TVAU19-N</p>	

MINI SERIES

3.0x3.5 Miniature Type Horizontal Push & Vertical Push Tact Switch



HOW TO ORDER

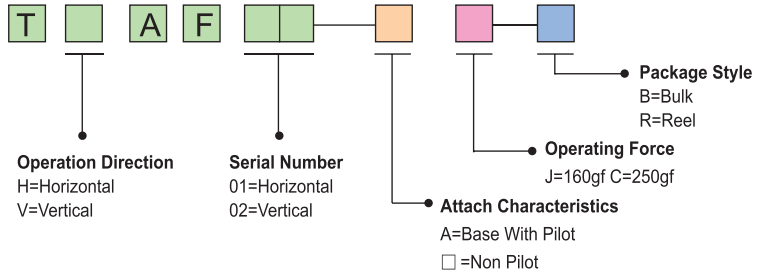

Specification

Items		Standard
Operating temperature range		-30℃ to +85℃
Electrical performance	Rating	50mA. 12V DC
	Insulation resistance	100MΩ min. 100V DC
	Dielectric strength	250V AC for 1 min.
	Contact resistance	100mΩ max.
Durability	Lifetime	100,000 Cycles
Mechanical performance	Operating force	J:160gf C:250gf
	Travel	0.13 ± 0.05mm

Diagram

No.	Dimensions	Circuit Diagram
		Pad Layout
1	<p>● THAF01</p>	
2	<p>● TVAF02</p>	

MINI SERIES

3.3x3.3 Miniature Type Tact Switch



TACT SWITCH



HOW TO ORDER

T V A F 0 3

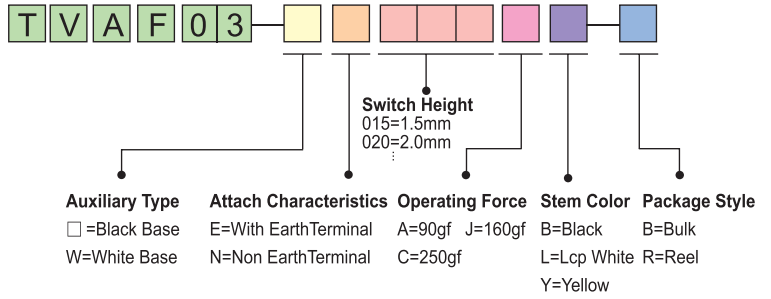

Specification

Items		Standard
Operating temperature range		-30°C to +85°C
Electrical performance	Rating	50mA, 12V DC
	Insulation resistance	100MΩ min. 100V DC
	Dielectric strength	250V AC for 1 min.
	Contact resistance	100mΩ max.
Durability	Lifetime	100,000 Cycles
Mechanical performance	Operating force	A:90gf J:160gf C:250gf
	Travel	0.20 ± 0.1mm

Diagram

No.	Dimensions	Circuit Diagram Pad Layout	
		Circuit Diagram	Pad Layout
1	<p>● TVAF03</p> <p>① ② ③ ④ ⑤</p> <p>H 1.5 2.0</p>	<p>Ground terminal</p> <p>4-0.7</p> <p>0.7</p> <p>2.5</p> <p>5</p> <p>2</p> <p>3</p> <p>3.5</p>	

MINI SERIES

3.3x3.3 Miniature Type Tact Switch

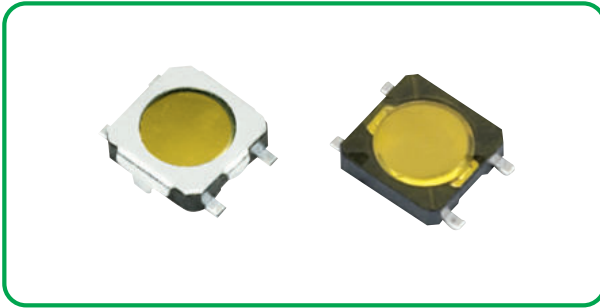

HOW TO ORDER

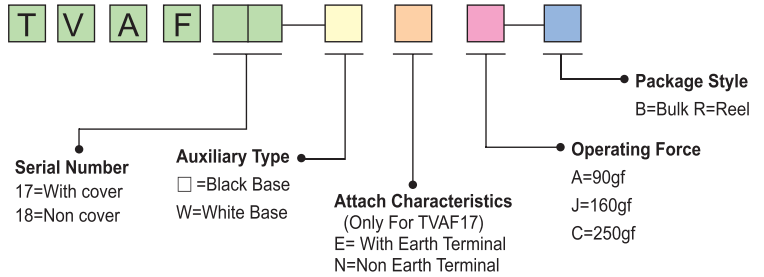

TACT SWITCH

Specification

Items		Standard
Operating temperature range		-30°C to +85°C
Electrical performance	Rating	50mA. 12V DC
	Insulation resistance	100MΩ min. 100V DC
	Dielectric strength	250V AC for 1 min.
	Contact resistance	100mΩ max.
Durability	Lifetime	100,000 Cycles
Mechanical performance	Operating force	A:90gf J:160gf C:250gf
	Travel	0.20 ± 0.1mm

Diagram

No.	Dimensions	Circuit Diagram Pad Layout
1	<p>● TVAF17</p>	
2	<p>● TVAF18</p>	

MINI SERIES

2.3x4.6 Miniature Type Tact Switch



TACT SWITCH

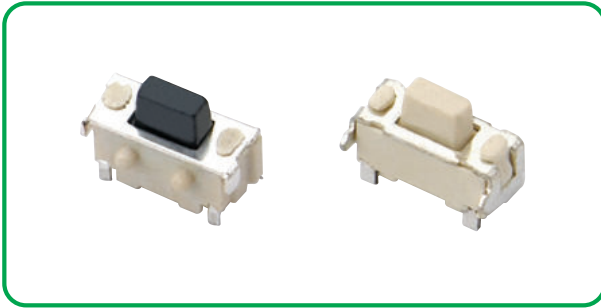

HOW TO ORDER

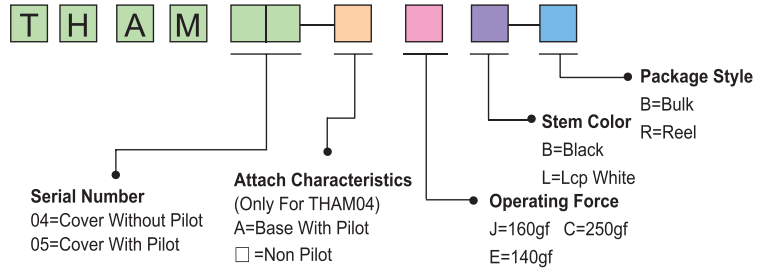

Specification

Items		Standard
Operating temperature range		-30℃ to +85℃
Electrical performance	Rating	50mA, 12V DC
	Insulation resistance	100MΩ min. 100V DC
	Dielectric strength	250V AC for 1 min.
	Contact resistance	100mΩ max.
Durability	Lifetime	A:J:E:50,000 Cycles C:30,000 Cycles
Mechanical performance	Operating force	J:160gf C:250gf E:140gf
	Travel	0.15 ± 0.05mm

Diagram

No.	Dimensions	Circuit Diagram Pad Layout
1	<p>● THAM04</p>	
2	<p>● THAM05</p>	

MINI SERIES

2.3x4.6 Miniature Type Tact Switch

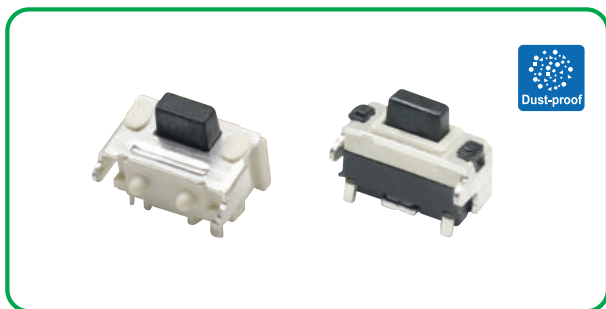

HOW TO ORDER

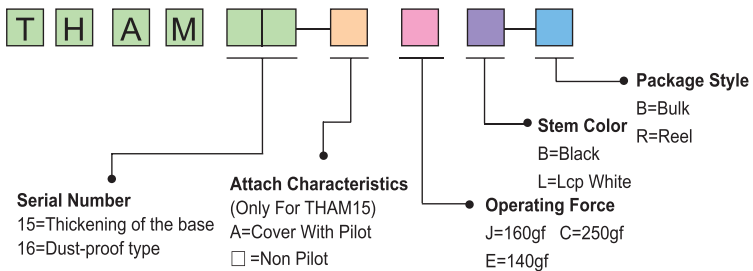

Specification

Items		Standard
Operating temperature range		-30℃ to +85℃
Electrical performance	Rating	50mA, 12V DC
	Insulation resistance	100MΩ min. 100V DC
	Dielectric strength	250V AC for 1 min.
	Contact resistance	100mΩ max.
Durability	Lifetime	E:J:50,000 Cycles C:30,000 Cycles
Mechanical performance	Operating force	J:160gf C:250gf E:140gf
	Travel	0.15 ± 0.05mm

Diagram

No.	Dimensions	Circuit Diagram
		Pad Layout
1	<p>● THAM15</p>	
2	<p>● THAM16</p>	

MINI SERIES

2.9x3.9 Miniature Type Vertical Push Tact Switch



TACT SWITCH



HOW TO ORDER

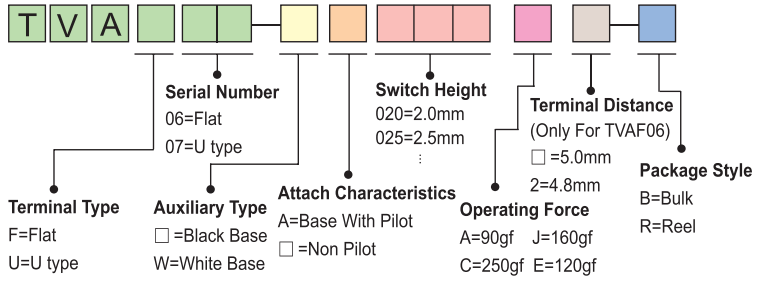

Specification

Items		Standard
Operating temperature range		-30℃ to +85℃
Electrical performance	Rating	50mA, 12V DC
	Insulation resistance	100MΩ min. 100V DC
	Dielectric strength	250V AC for 1 min.
	Contact resistance	100mΩ max.
Durability	Lifetime	100,000 Cycles
Mechanical performance	Operating force	A:90gf J:160gf C:250gf E:120gf
	Travel	0.13 ± 0.05mm

Diagram

No.	Dimensions	Circuit Diagram	
		Pad Layout	
1	<p>● TVAF06</p>	<p>H</p> <p>1.5</p> <p>2.0</p> <p>2.5</p> <p>3.0</p>	
2	<p>● TVAU07</p>	<p>H</p> <p>1.5</p> <p>2.0</p> <p>2.5</p> <p>3.0</p>	

MINI SERIES

2.9x3.9 Miniature Type Horizontal Push Tact Switch



HOW TO ORDER

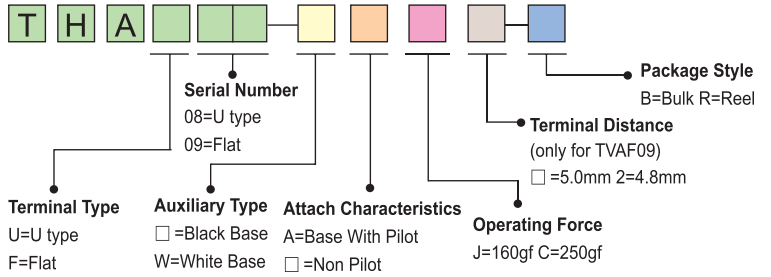

TACT SWITCH

Specification

Items		Standard
Operating temperature range		-30℃ to +85℃
Electrical performance	Rating	50mA, 12V DC
	Insulation resistance	100MΩ min. 100V DC
	Dielectric strength	250V AC for 1 min.
	Contact resistance	100mΩ max.
Durability	Lifetime	100,000 Cycles
Mechanical performance	Operating force	J:160gf C:250gf
	Travel	0.20 ± 0.1mm

Diagram

No.	Dimensions	Circuit Diagram Pad Layout
1	<p>● THAU08</p>	
2	<p>● THAF09</p>	

MINI SERIES

2.56x4.5 Miniature Type Horizontal Push Tact Switch



HOW TO ORDER

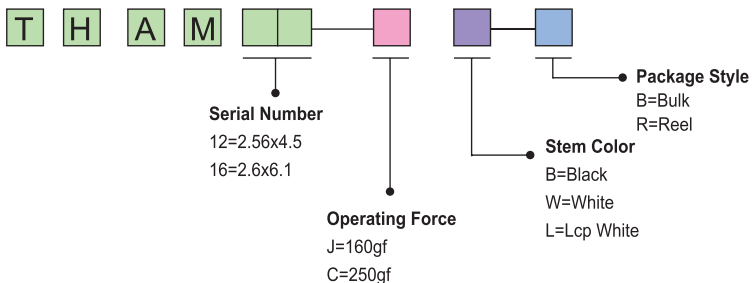

TACT SWITCH

Specification

Items		Standard
Operating temperature range		-30°C to +85°C
Electrical performance	Rating	50mA. 12V DC
	Insulation resistance	100MΩ min. 100V DC
	Dielectric strength	250V AC for 1 min.
	Contact resistance	500mΩ max.
Durability	Lifetime	100,000 Cycles
Mechanical performance	Operating force	J:160gf C:250gf
	Travel	0.20 ± 0.1mm

Diagram

No.	Dimensions	Circuit Diagram
		Pad Layout
1	<p>● THAM12</p>	
2	<p>● THAM16</p>	

MINI SERIES

3.5x4.7 Horizontal Push Tact Switch



TACT SWITCH

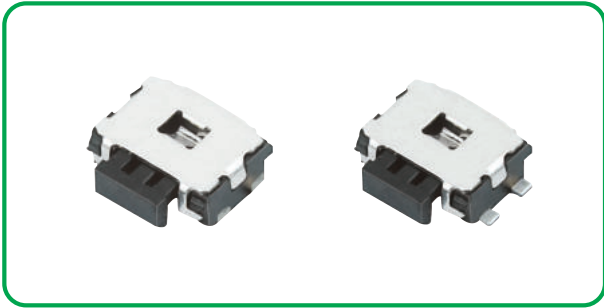

HOW TO ORDER

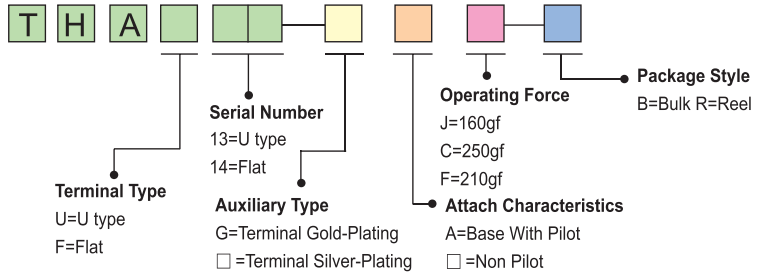

Specification

Items		Standard
Operating temperature range		-30℃ to +85℃
Electrical performance	Rating	50mA, 12V DC
	Insulation resistance	100MΩ min. 100V DC
	Dielectric strength	250V AC for 1 min.
	Contact resistance	100mΩ max.
Durability	Lifetime	100,000 Cycles
Mechanical performance	Operating force	J:160gf C:250gf F:210gf
	Travel	0.20 ± 0.1mm

Diagram

No.	Dimensions	Circuit Diagram Pad Layout
1	<p>● THAU13</p>	
2	<p>● THAF14</p>	

MINI SERIES

3.7x3.7 Miniature Type Tact Switch



HOW TO ORDER

T V A U 2 2

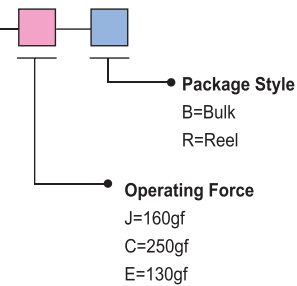

Specification

Items		Standard
Operating temperature range		-30°C to +85°C
Electrical performance	Rating	50mA, 12V DC
	Insulation resistance	100MΩ min. 100V DC
	Dielectric strength	250V AC for 1 min.
	Contact resistance	100mΩ max.
Durability	Lifetime	100,000 Cycles.
Mechanical performance	Operating force	J:180gf C:250gf E:130gf
	Travel	0.15 ± 0.05

Diagram

No.	Dimensions	Circuit Diagram
		Pad Layout
1	<p>● TVAU22</p>	

TACT SWITCH

MINI SERIES

3.5x4.7 Vertical Push Tact Switch



TACT SWITCH



HOW TO ORDER

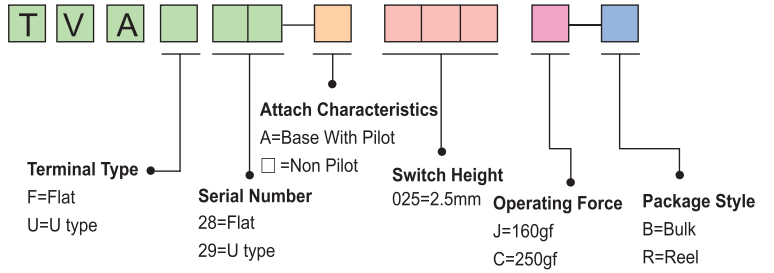

Specification

Items		Standard
Operating temperature range		-30°C to +85°C
Electrical performance	Rating	50mA. 12V DC
	Insulation resistance	100MΩ min. 100V DC
	Dielectric strength	250V AC for 1 min.
	Contact resistance	100mΩ max.
Durability	Lifetime	50,000 Cycles.
Mechanical performance	Operating force	J:160gf C:250gf
	Travel	0.20 ± 0.1mm

Diagram

No.	Dimensions	Circuit Diagram Pad Layout
1	<p>● TVAF28</p>	
2	<p>● TVAU29</p>	

MINI SERIES

3.5x4.7 Vertical Push Tact Switch



HOW TO ORDER

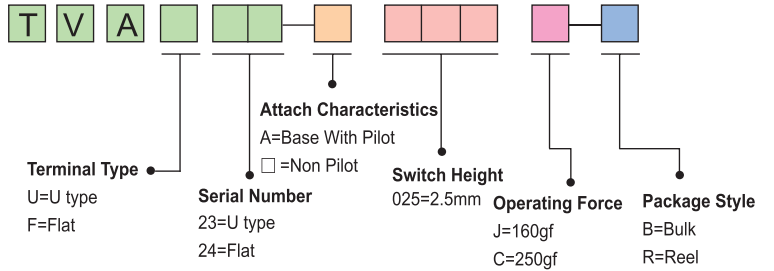

Specification

Items		Standard
Operating temperature range		-30°C to +85°C
Electrical performance	Rating	50mA. 12V DC
	Insulation resistance	100MΩ min. 100V DC
	Dielectric strength	250V AC for 1 min.
	Contact resistance	100mΩ max.
Durability	Lifetime	100,000 Cycles.
Mechanical performance	Operating force	J:160gf C:250gf
	Travel	0.20 ± 0.1mm

Diagram

No.	Dimensions	Circuit Diagram Pad Layout
1	<p>● TVAU23</p>	
2	<p>● TVAF24</p>	

3x6 SERIES

2.5x7.0 SMT & Right Angle Tact Switch



TACT SWITCH

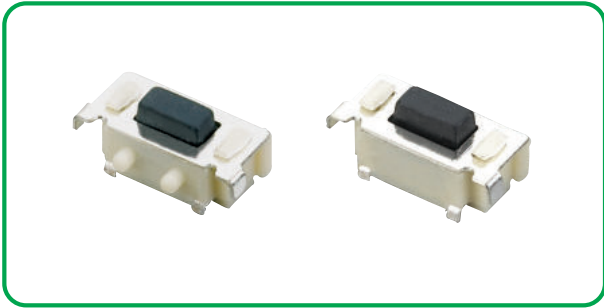

HOW TO ORDER

T	H	B	M						
Serial Number									Package Style
02=Base With Pilot									B=Bulk
03=Non Pilot									R=Reel
Auxiliary Type	Attach Characteristics			Operating Force			Internal Dot Mark		
□=Black Base	(Only For THBM02)			C=250gf			1=Terminal Lengthen		
L=Lcp White Base	A=Base With Pilot of φ0.8mm			D=70gf E=130gf			2=Non-Standard Height		
F=FR52 White Base	B=Base With Pilot of φ0.6mm			J=160gf G=320gf			3=Pilot Lengthen		
				C2=250gf(Double Contact)					

Specification

Items		Standard
Operating temperature range		-30°C to +85°C
Electrical performance	Rating	50mA. 12V DC
	Insulation resistance	100MΩ min. 100V DC
	Dielectric strength	250V AC for 1 min.
	Contact resistance	100mΩ max.
Durability	Lifetime	J:D:E:50,000Cycles C:G:30,000 Cycles
Mechanical performance	Operating force	C:250gf D:70gf E:130gf J:160gf G:320gf
	Travel	0.25 ± 0.1mm

Diagram

No.	Dimensions	Circuit Diagram			
		Pad Layout			
1	<p>● THBM02</p> <table border="1"> <tr><td>A</td></tr> <tr><td>φ0.6</td></tr> <tr><td>φ0.8</td></tr> </table>	A	φ0.6	φ0.8	
A					
φ0.6					
φ0.8					
2	<p>● THBM03</p>				

3x6 SERIES

3.5x6.0 Horizontal Push & Bracket Shape Tact Switch

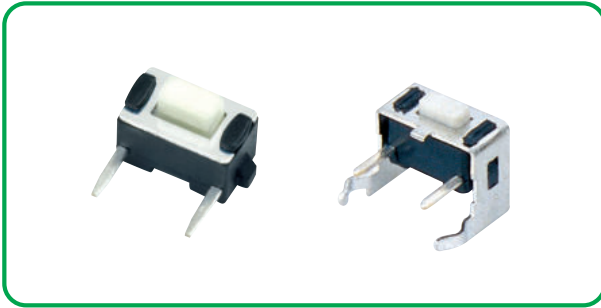

HOW TO ORDER

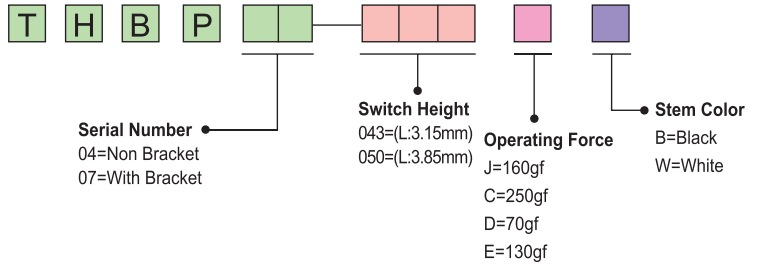

TACT SWITCH

Specification

Items		Standard
Operating temperature range		-30°C to +85°C
Electrical performance	Rating	50mA. 12V DC
	Insulation resistance	100MΩ min. 100V DC
	Dielectric strength	250V AC for 1 min.
	Contact resistance	100mΩ max.
Durability	Lifetime	D:E:J:50,000Cycles C:30,000 Cycles
Mechanical performance	Operating force	J:160gf C:250gf D:70gf E:130gf
	Travel	0.25 ± 0.1mm

Diagram

No.	Dimensions	Circuit Diagram			
		Pad Layout			
1	<p>● THBP04</p> <table border="1"> <tr><td>L</td></tr> <tr><td>3.15</td></tr> <tr><td>3.85</td></tr> </table>	L	3.15	3.85	
L					
3.15					
3.85					
2	<p>● THBP07</p> <table border="1"> <tr><td>L</td></tr> <tr><td>3.15</td></tr> <tr><td>3.85</td></tr> </table>	L	3.15	3.85	
L					
3.15					
3.85					

3x6 SERIES

4.0x6.1 Horizontal Push Tact Switch



TACT SWITCH



HOW TO ORDER

T H B M 0 5

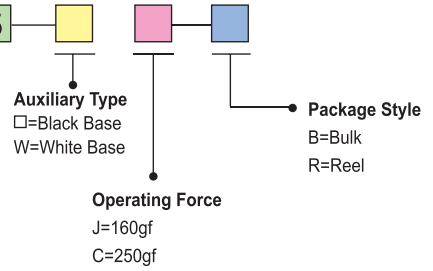

Specification

Items		Standard
Operating temperature range		-30°C to +85°C
Electrical performance	Rating	50mA, 12V DC
	Insulation resistance	100MΩ min. 100V DC
	Dielectric strength	250V AC for 1 min.
	Contact resistance	100mΩ max.
Durability	Lifetime	50,000 Cycles.
Mechanical performance	Operating force	J:160gf C:250gf
	Travel	0.30 ± 0.1mm

Diagram

No.	Dimensions	Circuit Diagram
		Pad Layout
1	<p>● THBM05</p> <p>Top view dimensions: 7.4, 6.1, 3.4, 0.6, 2.4, 1.4, 4, 6. Stem length: 1.8, 3.</p> <p>Side view dimension: 2±0.8.</p>	<p>Circuit diagram shows a switch with terminals 1, 2, 3, and 4.</p> <p>Pad layout shows a 2x2 grid of pads with dimensions: 2-φ0.9holes, 3, 4.3, 7.3, 2, 4.8.</p>

3x6 SERIES

3.5x6.0 Vertical Push Tact Switch

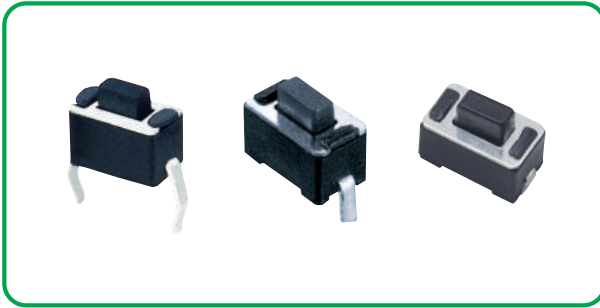

HOW TO ORDER

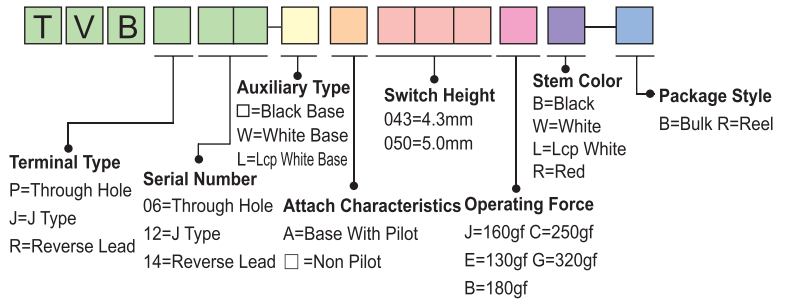

TACT SWITCH

Specification

Items		Standard
Operating temperature range		-20℃ to +70℃
Electrical performance	Rating	50mA. 12V DC
	Insulation resistance	100MΩ min. 100V DC
	Dielectric strength	250V AC for 1 min.
	Contact resistance	100mΩ max.
Durability	Lifetime	D:E:J:50,000Cycles C:30,000 Cycles
Mechanical performance	Operating force	J:160gf C:250gf D:70gf E:130gf B=180gf
	Travel	0.25 ± 0.1mm

Diagram

No.	Dimensions	Circuit Diagram			
		Pad Layout			
1	<p>● TVBP06</p> <table border="1"> <tr><td>H</td></tr> <tr><td>4.3</td></tr> <tr><td>5.0</td></tr> </table>	H	4.3	5.0	
H					
4.3					
5.0					
2	<p>● TVBJ12</p> <table border="1"> <tr><td>H</td></tr> <tr><td>4.3</td></tr> <tr><td>5.0</td></tr> </table>	H	4.3	5.0	
H					
4.3					
5.0					
3	<p>● TVBR14</p> <table border="1"> <tr><td>H</td></tr> <tr><td>4.3</td></tr> <tr><td>5.0</td></tr> </table>	H	4.3	5.0	
H					
4.3					
5.0					

3x6 SERIES

3.5x6.0 Vertical Push Tact Switch



TACT SWITCH

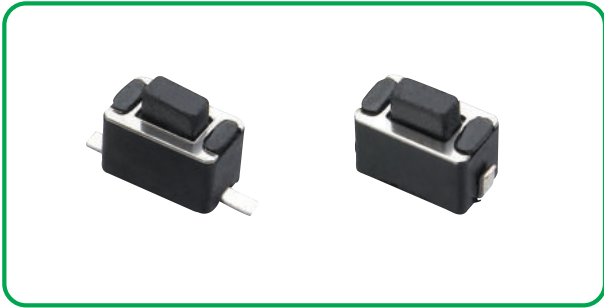

HOW TO ORDER

T	V	B							
Terminal Type	Serial Number	Auxiliary Type	Switch Height	Operating Force	Stem Color	Package Style			
F=Flat U=U Type	09=Flat 10=U Type	□=Black Base L=Lcp White Base W=White Base	043=4.3mm 050=5.0mm	A=90gf J=160gf C=250gf D=70gf E=130gf B=180gf	B=Black L=Lcp White S=Salmon W=White	B=Bulk R=Reel			

Specification

Items		Standard
Operating temperature range		-20°C to +70°C
Electrical performance	Rating	50mA. 12V DC
	Insulation resistance	100MΩ min. 100V DC
	Dielectric strength	250V AC for 1 min.
	Contact resistance	100mΩ max.
Durability	Lifetime	A:D:E:J:50,000Cycles C:30,000 Cycles
Mechanical performance	Operating force	A:90gf J:160gf C:250gf D:70gf E:130gf B:180gf
	Travel	0.25 ± 0.1mm

Diagram

No.	Dimensions	Circuit Diagram			
		Pad Layout			
1	<p>● TVBF09</p> <table border="1"> <tr><td>H</td></tr> <tr><td>4.3</td></tr> <tr><td>5.0</td></tr> </table>	H	4.3	5.0	
H					
4.3					
5.0					
2	<p>● TVBU10</p> <table border="1"> <tr><td>H</td></tr> <tr><td>4.3</td></tr> <tr><td>5.0</td></tr> </table>	H	4.3	5.0	
H					
4.3					
5.0					

3x6 SERIES

3.5x6.0 SMT Type Tact Switch

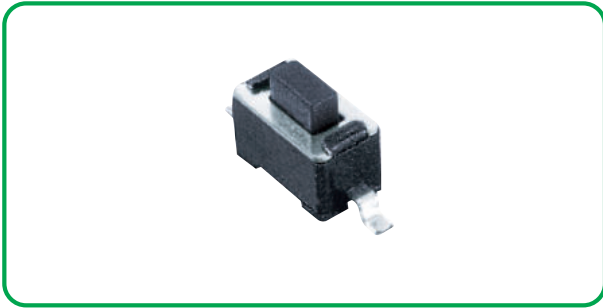

HOW TO ORDER

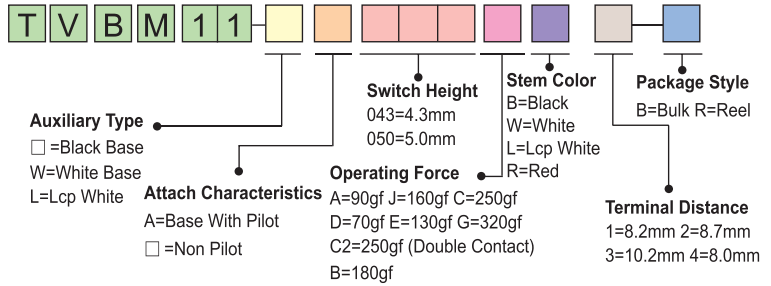

TACT SWITCH

Specification

Items		Standard
Operating temperature range		-20°C to +70°C
Electrical performance	Rating	50mA. 12V DC
	Insulation resistance	100MΩ min. 100V DC
	Dielectric strength	250V AC for 1 min.
	Contact resistance	100mΩ max.
Durability	Lifetime	A:D:E:J:50,000Cycles C:G:30,000 Cycles C2:100,000 Cycles
Mechanical performance	Operating force	A:90gf J:160gf C:250gf D:70gf E:130gf G:320gf B=180gf
	Travel	0.25 ± 0.1mm

Diagram

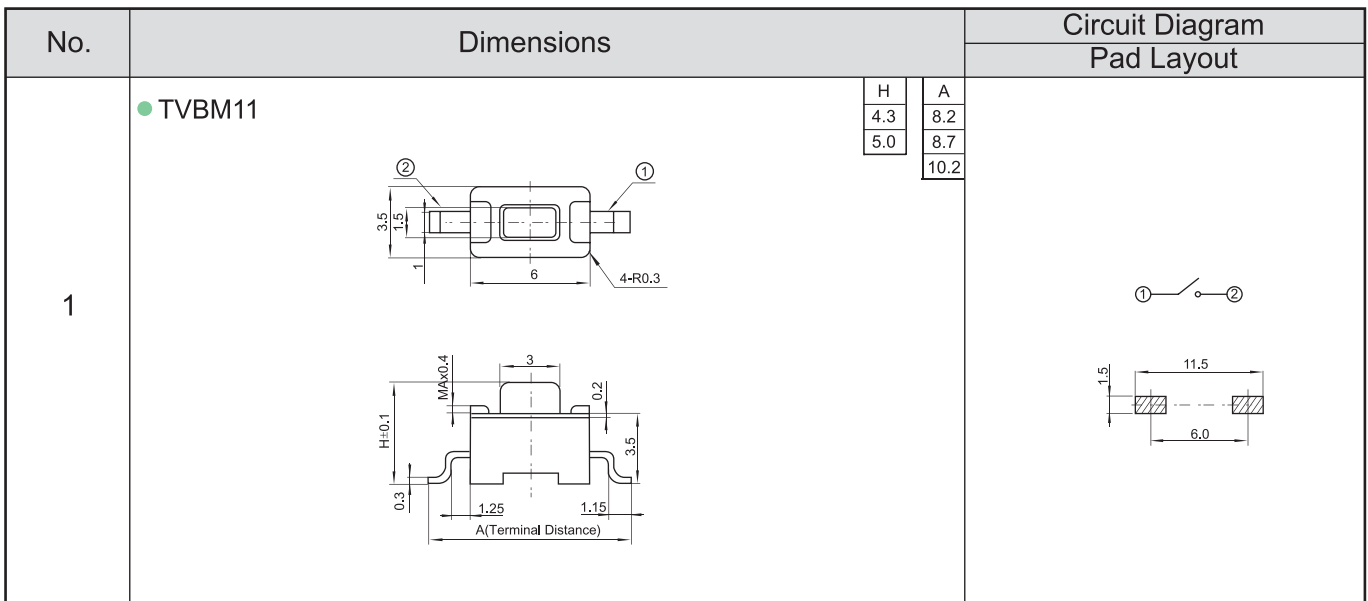

3x6 SERIES

3.5x6.0 Taping Type Tact Switch



TACT SWITCH

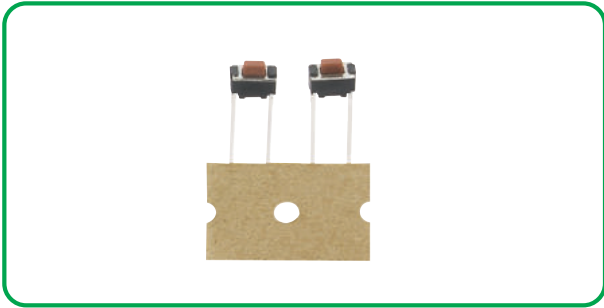

HOW TO ORDER

T V B T 1 6

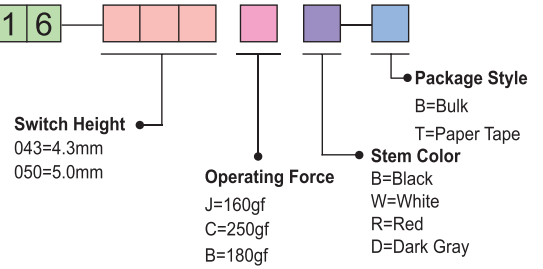

Specification

Items		Standard
Operating temperature range		-20°C to +70°C
Electrical performance	Rating	50mA, 12V DC
	Insulation resistance	100MΩ min. 100V DC
	Dielectric strength	250V AC for 1 min.
	Contact resistance	100mΩ max.
Durability	Lifetime	J:50,000Cycles C:30,000 Cycles
Mechanical performance	Operating force	J:160gf C:250gf B=180gf
	Travel	0.25 ± 0.1mm

Diagram

No.	Dimensions	Circuit Diagram
		Pad Layout
1	<p>● TVBT16</p> <p> H 4.3 5.0 </p>	

3x6 SERIES

3.7x6.1 SMT Type Tact Switch

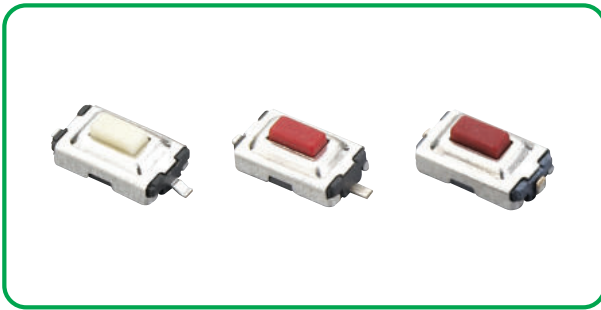

HOW TO ORDER

T	V	B									
Terminal Type M=S.M.T F=Flat U=U Type	Serial Number 17=S.M.T 18=Flat 19=U Type	Auxiliary Type □ =Black Base W=White Base L=LCP Black	Attach Characteristics □ =Dust-Proof P=Non Dust-Proof E=With Earth Terminal & Dust Proof	Switch Height 025=2.5mm 027=2.7mm	Operating Force A=90gf J=160gf C=250gf D=70gf E=130gf G=320gf C2=250gf (Double Contact) B=180gf	Package Style B=Bulk R=Reel	Stem Color L=Lcp White F=PPA White R=Red D=Dark Gray U=Blue				

TACT SWITCH

Specification

Items		Standard
Operating temperature range		-30°C to +85°C
Electrical performance	Rating	50mA. 12V DC
	Insulation resistance	100MΩ min. 100V DC
	Dielectric strength	250V AC for 1 min.
	Contact resistance	100mΩ max.
Durability	Lifetime	A:D:E:J:50,000Cycles C:G:30,000 Cycles C2:100,000 Cycles
Mechanical performance	Operating force	A:90gf J:160gf C:250gf D:70gf E:130gf G:320gf B=180gf
	Travel	0.25 ± 0.1mm

Diagram

No.	Dimensions	Circuit Diagram			
		Pad Layout			
1	<p>● TVBM17</p>	<table border="1"> <tr><th>H</th></tr> <tr><td>2.5</td></tr> <tr><td>2.7</td></tr> </table>	H	2.5	2.7
H					
2.5					
2.7					
2	<p>● TVBF18</p>				
3	<p>● TVBU19</p>				

3x6 SERIES

3.5x6.1 Through Hole & SMT Type Tact Switch



TACT SWITCH

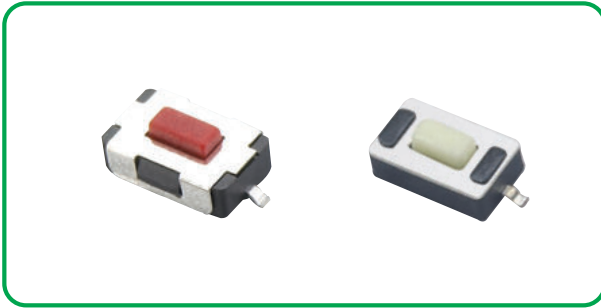

HOW TO ORDER

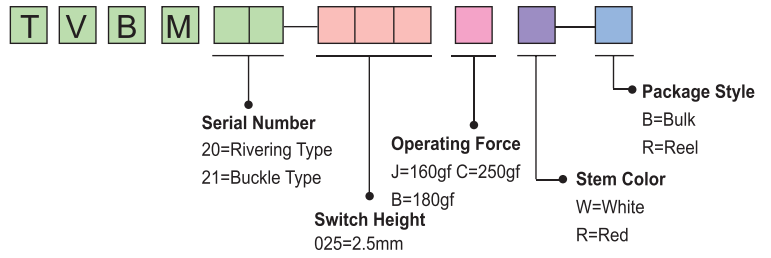

Specification

Items		Standard
Operating temperature range		-30°C to +85°C
Electrical performance	Rating	50mA. 12V DC
	Insulation resistance	100MΩ min. 100V DC
	Dielectric strength	250V AC for 1 min.
	Contact resistance	100mΩ max.
Durability	Lifetime	J:50,000Cycles C:30,000 Cycles
Mechanical performance	Operating force	J:160gf C:250gf B=180gf
	Travel	0.25 ± 0.1mm

Diagram

No.	Dimensions	Circuit Diagram
		Pad Layout
1	<p>● TVBM20</p>	
2	<p>● TVBP21</p>	

3x6 SERIES

3.8x6.0 Normal Closed Type Tact Switch



HOW TO ORDER

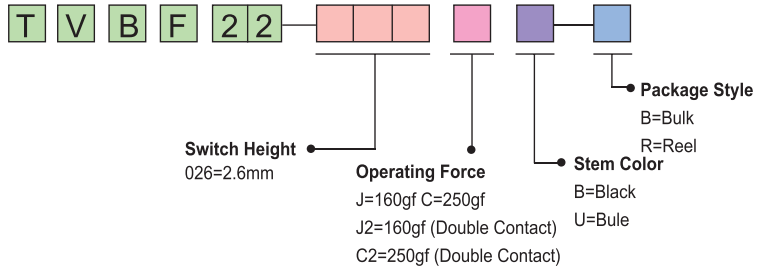

Specification

Items		Standard
Operating temperature range		-30°C to +85°C
Electrical performance	Rating	50mA, 12V DC
	Insulation resistance	100MΩ min. 100V DC
	Dielectric strength	250V AC for 1 min.
	Contact resistance	100mΩ max.
Durability	Lifetime	J:50,000 Cycles C:30,000 Cycles J2:C2:100,000 Cycles
Mechanical performance	Operating force	J:160gf C:250gf
	Travel	0.25 ± 0.1mm

Diagram

No.	Dimensions	Circuit Diagram
		Pad Layout
1	<p>● TVBF22</p>	

4.5x4.5 SERIES

4.5x4.5 Through Hole & SMT Type Tact Switch



TACT SWITCH

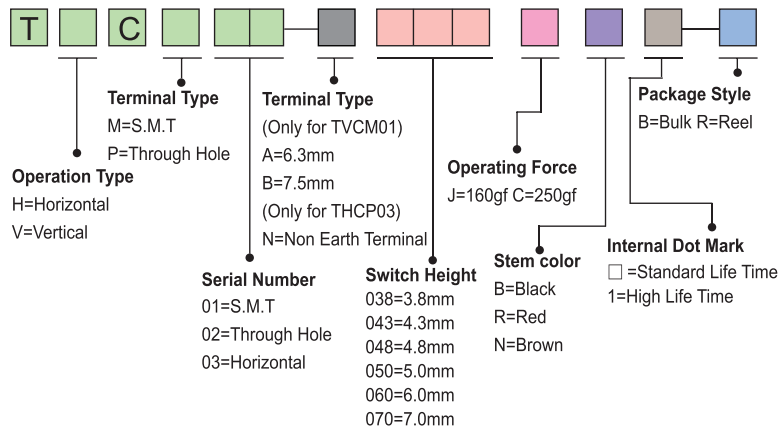
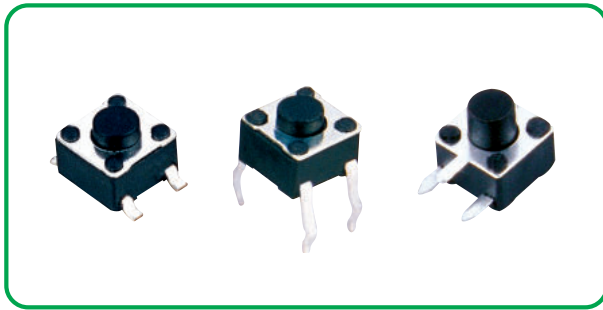

Specification

Items		Standard
Operating temperature range		-30℃ to +85℃
Electrical performance	Rating	50mA. 12V DC
	Insulation resistance	100MΩ min. 100V DC
	Dielectric strength	250V AC for 1 min.
	Contact resistance	100mΩ max.
Durability	Lifetime	J:100,000 Cycles C:50,000 Cycles
Mechanical performance	Operating force	J:160gf C:250gf
	Travel	0.25 ± 0.1mm

Diagram

No.	Dimensions	Circuit Diagram															
		Pad Layout															
1	<p>● TVCM01</p>	<table border="1"> <tr><th>H</th></tr> <tr><td>3.8</td></tr> <tr><td>4.3</td></tr> <tr><td>4.8</td></tr> <tr><td>5.0</td></tr> <tr><td>6.0</td></tr> <tr><td>7.0</td></tr> </table>	H	3.8	4.3	4.8	5.0	6.0	7.0								
H																	
3.8																	
4.3																	
4.8																	
5.0																	
6.0																	
7.0																	
2	<p>● TVCP02</p>	<table border="1"> <tr><th>H</th></tr> <tr><td>3.8</td></tr> <tr><td>4.3</td></tr> <tr><td>4.8</td></tr> <tr><td>5.0</td></tr> <tr><td>6.0</td></tr> <tr><td>7.0</td></tr> </table>	H	3.8	4.3	4.8	5.0	6.0	7.0								
H																	
3.8																	
4.3																	
4.8																	
5.0																	
6.0																	
7.0																	
3	<p>● THCP03</p>	<table border="1"> <tr><th>L</th><th>H</th></tr> <tr><td>6.5</td><td>3.8</td></tr> <tr><td>7.0</td><td>4.3</td></tr> <tr><td>7.5</td><td>4.8</td></tr> <tr><td></td><td>5.0</td></tr> <tr><td></td><td>6.0</td></tr> <tr><td></td><td>7.0</td></tr> </table>	L	H	6.5	3.8	7.0	4.3	7.5	4.8		5.0		6.0		7.0	
L	H																
6.5	3.8																
7.0	4.3																
7.5	4.8																
	5.0																
	6.0																
	7.0																

4.5x4.5 SERIES

4.3x4.5 SMT Type Tact Switch



HOW TO ORDER

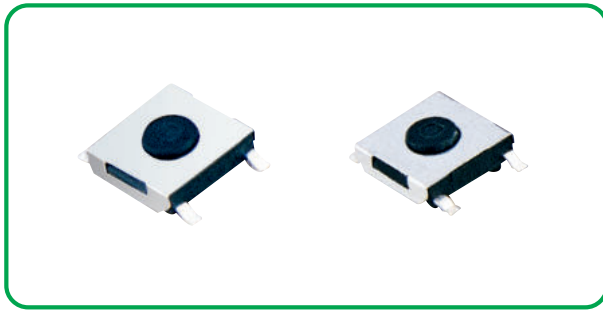
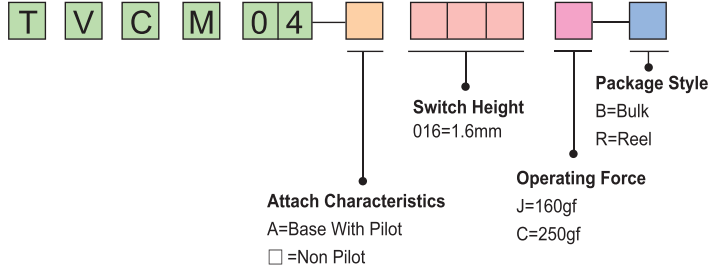

Specification

Items		Standard
Operating temperature range		-30°C to +85°C
Electrical performance	Rating	50mA. 12V DC
	Insulation resistance	100MΩ min. 100V DC
	Dielectric strength	250V AC for 1 min.
	Contact resistance	100mΩ max.
Durability	Lifetime	J:300,000 Cycles C:100,000 Cycles
Mechanical performance	Operating force	J:160gf C:250gf
	Travel	0.15 ± 0.05mm

Diagram

No.	Dimensions	Circuit Diagram
		Pad Layout
1	<p>● TVCM04-A</p>	
2	<p>● TVCM04-N</p>	

4.5x4.5 SERIES

4.5x4.5 Low-profile SMT Tact Switch



TACT SWITCH

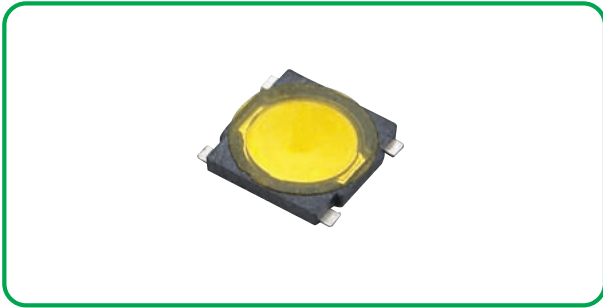

HOW TO ORDER

T V C M

09

Package Style
 B=Bulk
 R=Reel

Operating Force
 J=160gf
 C=250gf

Specification

Items		Standard
Operating temperature range		-20°C to +70°C
Electrical performance	Rating	50mA, 12V DC
	Insulation resistance	100MΩ min. 100V DC
	Dielectric strength	100V AC for 1 min.
	Contact resistance	100mΩ max.
Durability	Lifetime	J:500,000 Cycles C:200,000 Cycles
Mechanical performance	Operating force	J:160gf C:250gf
	Travel	0.15 ± 0.1mm

Diagram

No.	Dimensions	Circuit Diagram
		Pad Layout
1	● TVCM09 	

5.2x5.2 SERIES

5.2mm Square Low-Profile Type

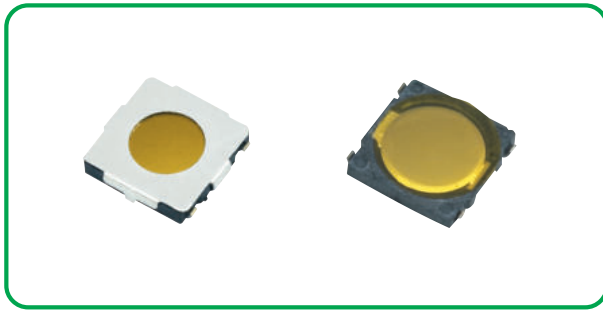

HOW TO ORDER

T V C U

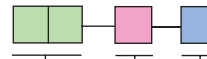

Serial Number
11=With Cover
12=Non Cover

Operating Force
A=90gf J=160gf
C=250gf D=70gf
E=130gf G=320gf

Package Style
B=Bulk R=Reel

Specification

Items		Standard
Operating temperature range		-20°C to +70°C
Electrical performance	Rating	50mA. 12V DC
	Insulation resistance	100MΩ min. 100V DC
	Dielectric strength	100V AC for 1 min.
	Contact resistance	100mΩ max.
Durability	Lifetime	A:J:D:E:F:200,000 Cycles C:G:100,000 Cycles
Mechanical performance	Operating force	A:90gf J:160gf C:250gf D:70gf E:130gf G:320gf
	Travel	0.25 ± 0.1mm

Diagram

No.	Dimensions	Circuit Diagram Pad Layout
1	<p>● TVCU11</p>	
2	<p>● TVCU12</p>	

FACT SWITCH

5.2x5.2 SERIES

4.8x4.8 Low-profile SMT Tact Switch



TACT SWITCH

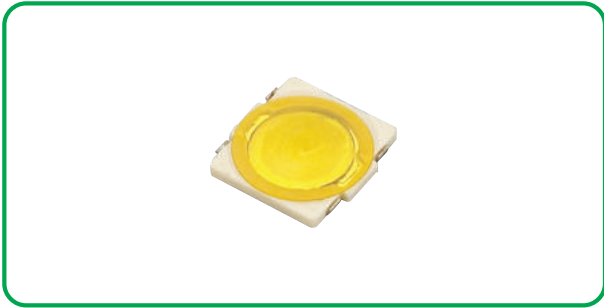

HOW TO ORDER

T V C U

13

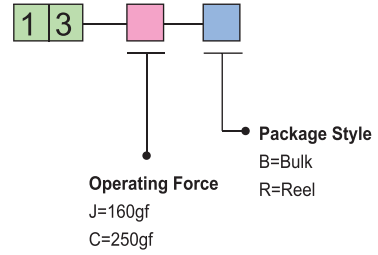

Specification

Items		Standard
Operating temperature range		-20°C to +70°C
Electrical performance	Rating	50mA. 12V DC
	Insulation resistance	100MΩ min. 100V DC
	Dielectric strength	100V AC for 1 min.
	Contact resistance	100mΩ max.
Durability	Lifetime	J:500,000 Cycles C:200,000 Cycles
Mechanical performance	Operating force	J:160gf C:250gf
	Travel	0.20 ± 0.05mm

Diagram

No.	Dimensions	Circuit Diagram Pad Layout
1	<p>● TVCU13</p>	

5.2x5.2 SERIES

5.2x5.2 SMT Tact Switch



HOW TO ORDER

T V C M 15

Auxiliary Type
 □ = Black Base
 W = White Base
 L = LCP Black Base

Switch Height
 010 = 1.0mm (With Cover)
 008 = 0.8mm (Non Cover)

Operating Force
 A = 90gf J = 160gf
 C = 250gf D = 70gf
 E = 130gf G = 320gf

Package Style
 B = Bulk
 R = Reel

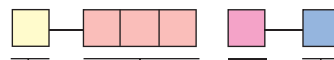

TACT SWITCH

Specification

Items		Standard
Operating temperature range		-30°C to +85°C
Electrical performance	Rating	50mA, 12V DC
	Insulation resistance	100MΩ min. 100V DC
	Dielectric strength	250V AC for 1 min.
	Contact resistance	100mΩ max.
Durability	Lifetime	E: J: 200,000 Cycles C: 100,000 Cycles
Mechanical performance	Operating force	A: 90gf J: 160gf C: 250gf D: 70gf E: 130gf G: 320gf
	Travel	0.25 ± 0.1mm

Diagram

No.	Dimensions	Circuit Diagram
		Pad Layout
1	<p>● TVCM15-010</p>	
2	<p>● TVCM15-008</p>	

5.2x5.2 SERIES

5.2x5.2 SMT Tact Switch



TACT SWITCH



HOW TO ORDER

T	V	C	M								
Serial Number 16=Square Cover 17=Round Cover	Auxiliary Type □ =Black Base W=White Base L=Lcp Black Base	Switch Height 015=1.5mm 016=1.6mm 017=1.7mm 020=2.0mm 025=2.5mm 035=3.5mm 043=4.3mm	Stem Color L=Lcp White F=PPA White B=Black Y=Yellow P=Nickel Plating	Package Style B=Bulk R=Reel	Attach Characteristics □ =Dust-Proof E=With Earth Terminal	Operating Force A=90gf J=160gf C=250gf D=70gf E=130gf G=320gf H=400gf I=520gf	Internal Dot Mark □ =Standard 1=High Life Time 2=Terminal of 6.0mm				

Specification

Items		Standard
Operating temperature range		-30°C to +85°C
Electrical performance	Rating	50mA. 12V DC
	Insulation resistance	100MΩ min. 100V DC
	Dielectric strength	250V AC for 1 min.
	Contact resistance	100mΩ max.
Durability	Lifetime	A::J:D:E:200,000 Cycles C::G:H:I:100,000 Cycles
Mechanical performance	Operating force	A:90gf J:160gf C:250gf D:70gf E:130gf G:320gf H:400gf I:520gf
	Travel	0.25 ± 0.1mm

Diagram

No.	Dimensions	Circuit Diagram	
		Pad Layout	
1	<p>● TVCM16</p>	H	
		1.5	
2	<p>● TVCM17</p>	H	
		1.5	

5.2x5.2 SERIES

5.2x5.2 With Ground Terminal Tact Switch



HOW TO ORDER

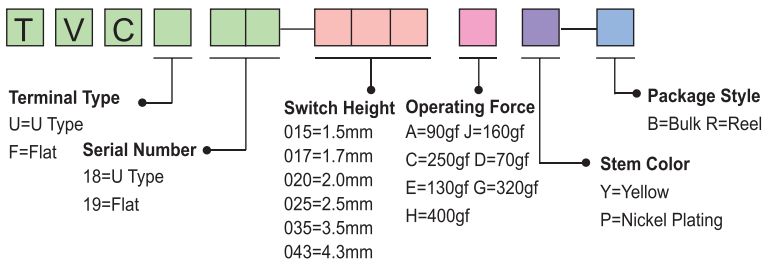

Specification

Items		Standard
Operating temperature range		-30°C to +85°C
Electrical performance	Rating	50mA. 12V DC
	Insulation resistance	100MΩ min. 100V DC
	Dielectric strength	250V AC for 1 min.
	Contact resistance	100mΩ max.
Durability	Lifetime	A:J:D:E:200,000 Cycles C:G:H:100,000 Cycles
Mechanical performance	Operating force	A:90gf J:160gf C:250gf D:70gf E:130gf G:320gf H:400gf
	Travel	0.25 ± 0.1mm

Diagram

No.	Dimensions	Circuit Diagram Pad Layout
1	<p>● TVCU18</p>	
2	<p>● TVCF19</p>	

6x6 SERIES

6.0x6.0 Through Hole Type Tact Switch



TACT SWITCH

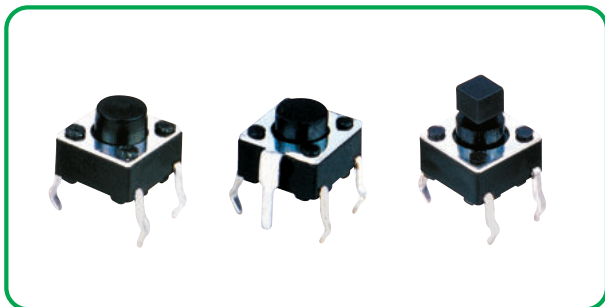

HOW TO ORDER

T V D P [Color Swatches]

Serial Number
01=Standard
02=With Earth Terminal

Switch Height
043=4.3mm
050=5.0mm
055=5.5mm
060=6.0mm
065=6.5mm
070=7.0mm
G73=7.3mm
:

Operating Force
A=90gf B=180gf
C=250gf D=70gf
E=130gf J=160gf
F=210gf G=320gf
H=400gf I=520gf
:

Stem Color
B=Black
W=White
R=Red
N=Brown
S=Salmon

Internal Dot Mark
□ =Standard Life time
1=High Lifetime
2=Brass Cover
3=High Lifetime & Brass Cover
4=PET Cover
5=High Lifetime & PET Cover
6=Plastic Fits UL 94V-0
7=High Lifetime & Plastic Fits UL 94V-0
8=Non-rotating Stem
9=Push No Sound

Specification

Items		Standard
Operating temperature range		-30℃ to +85℃
Electrical performance	Rating	50mA. 12V DC
	Insulation resistance	100MΩ min. 100V DC
	Dielectric strength	250V AC for 1 min.
	Contact resistance	100mΩ max.
Durability	Lifetime	A:D:300,000 Cycles J:E:J:F:C:100,000 Cycles G:H:50,000 Cycles
Mechanical performance	Operating force	A:90gf D:70gf J:160gf E:130gf J:160gf F:210gf G:320gf H:400gf C:250gf
	Travel	0.25 ± 0.1mm

Diagram

No.	Dimensions	Circuit Diagram														
		Pad Layout														
1	<p>● TVDP01</p> <table border="1"> <thead> <tr> <th>H</th> <th>A</th> </tr> </thead> <tbody> <tr><td>4.3</td><td>3.5</td></tr> <tr><td>5</td><td>3.5</td></tr> <tr><td>7</td><td>3.3</td></tr> <tr><td>9.5</td><td>3</td></tr> <tr><td>13</td><td>3</td></tr> <tr><td>17</td><td>3</td></tr> </tbody> </table>	H	A	4.3	3.5	5	3.5	7	3.3	9.5	3	13	3	17	3	
H	A															
4.3	3.5															
5	3.5															
7	3.3															
9.5	3															
13	3															
17	3															
2	<p>● TVDP02</p> <table border="1"> <thead> <tr> <th>H</th> <th>A</th> </tr> </thead> <tbody> <tr><td>4.3</td><td>3.5</td></tr> <tr><td>5</td><td>3.5</td></tr> <tr><td>7</td><td>3.3</td></tr> <tr><td>9.5</td><td>3</td></tr> </tbody> </table>	H	A	4.3	3.5	5	3.5	7	3.3	9.5	3					
H	A															
4.3	3.5															
5	3.5															
7	3.3															
9.5	3															
3	<p>● TVDP01-G73</p>															

6x6 SERIES

6.0x6.0 Bracket Shape Type Tact Switch



HOW TO ORDER

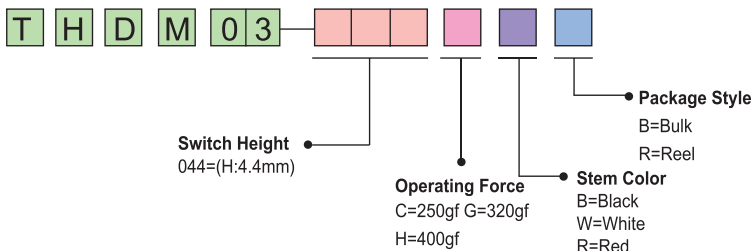

TACT SWITCH

Specification

Items		Standard
Operating temperature range		-20°C to +70°C
Electrical performance	Rating	50mA. 12V DC
	Insulation resistance	100MΩ min. 100V DC
	Dielectric strength	250V AC for 1 min.
	Contact resistance	100mΩ max.
Durability	Lifetime	C:50,000 Cycles G:H:30,000 Cycles
Mechanical performance	Operating force	C:250gf G:320gf H:400gf
	Travel	0.30 ± 0.1mm

Diagram

No.	Dimensions	Circuit Diagram Pad Layout
1	<p>● THDM03</p>	

6x6 SERIES

6.0x6.0 Surface Mounting Tact Switch



TACT SWITCH



HOW TO ORDER

T V D M [Color] [Color] [Color] [Color] [Color]

Terminal Type
 A=8.2mm
 B=9.2mm
 C=10.2mm
 D=8.6mm
 E=8.0mm
 F=9.0mm
 G=10.0mm

Switch Height
 043=4.3mm
 050=5.0mm
 055=5.5mm
 060=6.0mm
 065=6.5mm
 070=7.0mm
 G73=7.3mm
 :

Operating Force
 A=90gf B=180gf
 C=250gf D=70gf
 E=130gf J=160gf
 G=320gf H=400gf
 I=520gf

Stem Color
 B=Black
 W=White
 R=Red
 D=Dark Gray
 N=Brown
 S=Salmon

Internal Dot Mark
 □ = Standard Lifetime
 1=High Lifetime
 2=Brass Cover
 3=High Lifetime & Brass Cover
 4=PET Cover
 5=High Lifetime & PET Cover
 6=Plastic Fits UL94V-0
 7=High Lifetime&Plastic Fits UL94V-0
 8=Non-Fotating stem
 9=Push No Sound

Package Style
 B=Bulk R=Reel

Serial Number
 04=standard
 25=With Earth Terminal

Specification

Items		Standard
Operating temperature range		-30°C to +85°C
Electrical performance	Rating	50mA. 12V DC
	Insulation resistance	100MΩ min. 100V DC
	Dielectric strength	250V AC for 1 min.
	Contact resistance	100mΩ max.
Durability	Lifetime	A:D:300,000 Cycles E:J:C:100,000 Cycles G:H:50,000 Cycles
Mechanical performance	Operating force	A:90gf J:160gf C:250gf D:70gf E:130gf G:320gf H:400gf I:520gf
	Travel	0.25 ± 0.1mm

Diagram

No.	Dimensions	Circuit Diagram														
		Pad Layout														
1	<p>● TVDM04</p> <table border="1"> <tr><th>H</th><th>A</th></tr> <tr><td>4.3</td><td>3.5</td></tr> <tr><td>5</td><td>3.5</td></tr> <tr><td>7</td><td>3.3</td></tr> <tr><td>9.5</td><td>3</td></tr> <tr><td>13</td><td>3</td></tr> <tr><td>17</td><td>3</td></tr> </table>	H	A	4.3	3.5	5	3.5	7	3.3	9.5	3	13	3	17	3	
H	A															
4.3	3.5															
5	3.5															
7	3.3															
9.5	3															
13	3															
17	3															
2	<p>● TVDM04-G73</p>															
3	<p>● TVDM25</p>															

6x6 SERIES

6.0x6.0 Other Terminal Shape Tact Switch

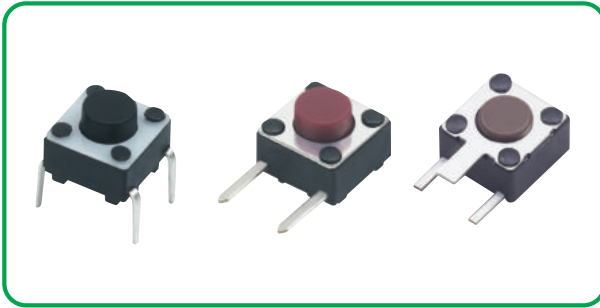

HOW TO ORDER

T	D							
Terminal Type		Switch Height		Operating Force		Stem Color		
J=J Type	P=Through Hole	043=4.3mm	050=5.0mm	A=90gf	J=160gf	B=Black	R=Red	N=Brown
Serial Number		055=5.5mm	060=6.0mm	C=250gf	D=70gf	Internal Dot Mark		
06=J Type	07=Through Hole	065=6.5mm	070=7.0mm	E=130gf	G=320gf	□ =Standard Lifetime	1=High Lifetime	2=Brass Cover
H:Horizontal	19=With Earth Terminal	G73=7.3mm		H=400gf		3=High Lifetime & Brass Cover	4=PET Cover	5=High Lifetime & PET Cover
V:Vertical								

TACT SWITCH

Specification

Items		Standard
Operating temperature range		-30℃ to +85℃
Electrical performance	Rating	50mA. 12V DC
	Insulation resistance	100MΩ min. 100V DC
	Dielectric strength	250V AC for 1 min.
	Contact resistance	100mΩ max.
Durability	Lifetime	A:D:300,000 Cycles J:E:F:C:100,000 Cycles G:H:50,000 Cycles
Mechanical performance	Operating force	A:90gf D:70gf J:160gf E:130gf C:250gf G:320gf H:400gf
	Travel	0.25 ± 0.1mm

Diagram

No.	Dimensions	Circuit Diagram															
		Pad Layout															
1	<p>● TVDJ06</p> <table border="1"> <thead> <tr> <th>H</th> <th>A</th> </tr> </thead> <tbody> <tr><td>4.3</td><td>φ3.5</td></tr> <tr><td>5.0</td><td>φ3.4</td></tr> <tr><td>5.5</td><td>φ3.4</td></tr> <tr><td>6.0</td><td>φ3.3</td></tr> <tr><td>6.5</td><td>φ3.3</td></tr> <tr><td>7.0</td><td>φ3.3</td></tr> </tbody> </table>	H	A	4.3	φ3.5	5.0	φ3.4	5.5	φ3.4	6.0	φ3.3	6.5	φ3.3	7.0	φ3.3		
H	A																
4.3	φ3.5																
5.0	φ3.4																
5.5	φ3.4																
6.0	φ3.3																
6.5	φ3.3																
7.0	φ3.3																
2	<p>● THDP07</p> <table border="1"> <thead> <tr> <th>H</th> <th>A</th> </tr> </thead> <tbody> <tr><td>4.3</td><td>φ3.5</td></tr> <tr><td>5.0</td><td>φ3.4</td></tr> <tr><td>5.5</td><td>φ3.4</td></tr> <tr><td>6.0</td><td>φ3.3</td></tr> <tr><td>6.5</td><td>φ3.3</td></tr> <tr><td>7.0</td><td>φ3.3</td></tr> </tbody> </table>	H	A	4.3	φ3.5	5.0	φ3.4	5.5	φ3.4	6.0	φ3.3	6.5	φ3.3	7.0	φ3.3		
H	A																
4.3	φ3.5																
5.0	φ3.4																
5.5	φ3.4																
6.0	φ3.3																
6.5	φ3.3																
7.0	φ3.3																
3	<p>● THDP19</p>																

6x6 SERIES

6.0x6.0 Bracket Shape Type Tact Switch



TACT SWITCH

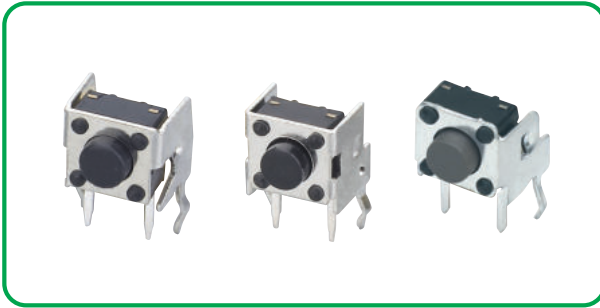

HOW TO ORDER

T H D P [Color Box] [Color Box] [Color Box] [Color Box]

Serial Number
 08=Standard Type
 09=Bracket with Hole
 10=Non-Standard Type

Switch Height
 043=(L:3.15mm)
 050=(L:3.85mm)
 055=(L:4.35mm)
 060=(L:4.85mm)
 070=(L:5.85mm)

Operating Force
 A=90gf
 J=160gf
 C=250gf

Life time
 □ =Standard Lifetime
 1=High Lifetime

Stem Color
 B=Black
 R=Red
 N=Brown

Specification

Items		Standard
Operating temperature range		-30℃ to +85℃
Electrical performance	Rating	50mA, 12V DC
	Insulation resistance	100MΩ min. 100V DC
	Dielectric strength	250V AC for 1 min.
	Contact resistance	100mΩ max.
Durability	Lifetime	A:300,000 Cycles J: C:100,000 Cycles
Mechanical performance	Operating force	A:90gf J:160gf C:250gf
	Travel	0.25 ± 0.1mm

Diagram

No.	Dimensions	Circuit Diagram												
		Pad Layout												
1	<p>● THDP08</p> <table border="1"> <thead> <tr> <th>L</th> <th>A</th> </tr> </thead> <tbody> <tr><td>3.15</td><td>3.5</td></tr> <tr><td>3.85</td><td>3.5</td></tr> <tr><td>5.85</td><td>3.3</td></tr> <tr><td>8.35</td><td>3</td></tr> <tr><td>15.85</td><td>3</td></tr> </tbody> </table>	L	A	3.15	3.5	3.85	3.5	5.85	3.3	8.35	3	15.85	3	
L	A													
3.15	3.5													
3.85	3.5													
5.85	3.3													
8.35	3													
15.85	3													
2	<p>● THDP09</p> <table border="1"> <thead> <tr> <th>L</th> <th>A</th> </tr> </thead> <tbody> <tr><td>3.15</td><td>3.5</td></tr> <tr><td>3.85</td><td>3.5</td></tr> <tr><td>5.85</td><td>3.3</td></tr> <tr><td>8.35</td><td>3</td></tr> <tr><td>15.85</td><td>3</td></tr> </tbody> </table>	L	A	3.15	3.5	3.85	3.5	5.85	3.3	8.35	3	15.85	3	
L	A													
3.15	3.5													
3.85	3.5													
5.85	3.3													
8.35	3													
15.85	3													
3	<p>● THDP10</p> <table border="1"> <thead> <tr> <th>L</th> <th>A</th> </tr> </thead> <tbody> <tr><td>3.15</td><td>3.5</td></tr> <tr><td>3.85</td><td>3.5</td></tr> <tr><td>5.85</td><td>3.3</td></tr> <tr><td>8.35</td><td>3</td></tr> <tr><td>15.85</td><td>3</td></tr> </tbody> </table>	L	A	3.15	3.5	3.85	3.5	5.85	3.3	8.35	3	15.85	3	
L	A													
3.15	3.5													
3.85	3.5													
5.85	3.3													
8.35	3													
15.85	3													

6x6 SERIES

6.0x6.0 Other Bracket Shape Type Tact Switch

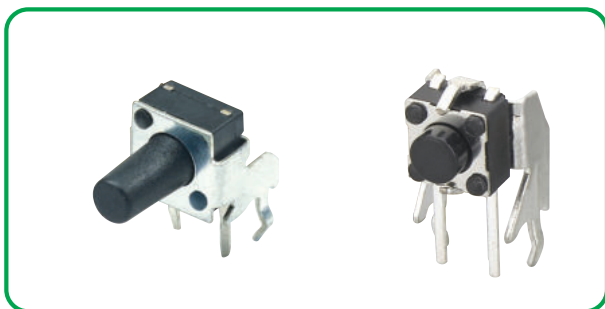

HOW TO ORDER

T H D P [Color Swatches]

Serial Number
 11=Short Bracket
 12=Long Bracket

Switch Height
 043=(L:3.15mm)
 050=(L:3.85mm)
 055=(L:4.35mm)
 060=(L:4.85mm)
 070=(L:5.85mm)
 090=(L:7.85mm)

Operating Force
 J=160gf
 C=250gf

Stem Color
 B=Black
 R=Red
 N=Brown

Specification

Items		Standard
Operating temperature range		-30°C to +85°C
Electrical performance	Rating	50mA. 12V DC
	Insulation resistance	100MΩ min. 100V DC
	Dielectric strength	250V AC for 1 min.
	Contact resistance	100mΩ max.
Durability	Lifetime	J:C:100,000 Cycles
Mechanical performance	Operating force	J:160gf C:250gf
	Travel	0.25 ± 0.1mm

Diagram

No.	Dimensions	Circuit Diagram												
		Pad Layout												
1	<p>● THDP11</p> <table border="1"> <thead> <tr> <th>L</th> <th>A</th> </tr> </thead> <tbody> <tr><td>3.15</td><td>3.5</td></tr> <tr><td>3.85</td><td>3.5</td></tr> <tr><td>5.85</td><td>3.3</td></tr> <tr><td>8.35</td><td>3</td></tr> <tr><td>15.85</td><td>3</td></tr> </tbody> </table>	L	A	3.15	3.5	3.85	3.5	5.85	3.3	8.35	3	15.85	3	
L	A													
3.15	3.5													
3.85	3.5													
5.85	3.3													
8.35	3													
15.85	3													
2	<p>● THDP12</p> <table border="1"> <thead> <tr> <th>L</th> <th>A</th> </tr> </thead> <tbody> <tr><td>3.15</td><td>3.5</td></tr> <tr><td>3.85</td><td>3.5</td></tr> <tr><td>5.85</td><td>3.3</td></tr> <tr><td>8.35</td><td>3</td></tr> <tr><td>15.85</td><td>3</td></tr> </tbody> </table>	L	A	3.15	3.5	3.85	3.5	5.85	3.3	8.35	3	15.85	3	
L	A													
3.15	3.5													
3.85	3.5													
5.85	3.3													
8.35	3													
15.85	3													

6x6 SERIES

6.0x6.0 SMT & Bracket Shape Type Tact Switch



TACT SWITCH



HOW TO ORDER

T H D M 1 3

Attach Characteristics
 A: Cover with pilot of 3.0mm
 B: Cover with pilot of 1.3mm

Switch Height
 043=(L:3.15mm)
 050=(L:3.85mm)
 055=(L:4.35mm)
 060=(L:4.85mm)
 065=(L:5.35mm)
 070=(L:5.85mm)

Operating Force
 A=90gf
 J=160gf
 C=250gf

Stem Color
 B=Black
 R=Red
 D=Dark Gray

Internal Dot Mark
 =Standard

Package Style
 B=Bulk R=Reel

Specification

Items		Standard
Operating temperature range		-30℃ to +85℃
Electrical performance	Rating	50mA. 12V DC
	Insulation resistance	100MΩ min. 100V DC
	Dielectric strength	250V AC for 1 min.
	Contact resistance	100mΩ max.
Durability	Lifetime	A:300,000 Cycles J:C:100,000 Cycles
Mechanical performance	Operating force	A:90gf J:160gf C:250gf
	Travel	0.25 ± 0.1mm

Diagram

No.	Dimensions	Circuit Diagram																							
		Pad Layout																							
1	<p>● THDM13</p>	<table border="1"> <thead> <tr> <th>L</th> <th>A</th> <th>B</th> </tr> </thead> <tbody> <tr> <td>3.15</td> <td>3.5</td> <td>1.3</td> </tr> <tr> <td>3.85</td> <td>3.5</td> <td>3.0</td> </tr> <tr> <td>4.35</td> <td>3.3</td> <td></td> </tr> <tr> <td>4.85</td> <td>3.3</td> <td></td> </tr> <tr> <td>5.35</td> <td>3.3</td> <td></td> </tr> <tr> <td>5.85</td> <td>3.3</td> <td></td> </tr> </tbody> </table>	L	A	B	3.15	3.5	1.3	3.85	3.5	3.0	4.35	3.3		4.85	3.3		5.35	3.3		5.85	3.3		<p>CIRCUIT DIAGRAM</p> <p>P.C.B LAND DIMENSION</p>	
			L	A	B																				
3.15	3.5	1.3																							
3.85	3.5	3.0																							
4.35	3.3																								
4.85	3.3																								
5.35	3.3																								
5.85	3.3																								

6x6 SERIES

6.0x6.0 Radial Taping Type Tact Switch

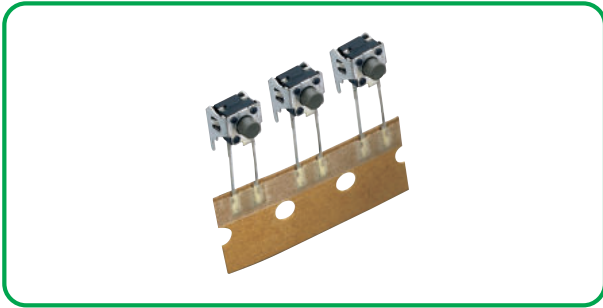

HOW TO ORDER

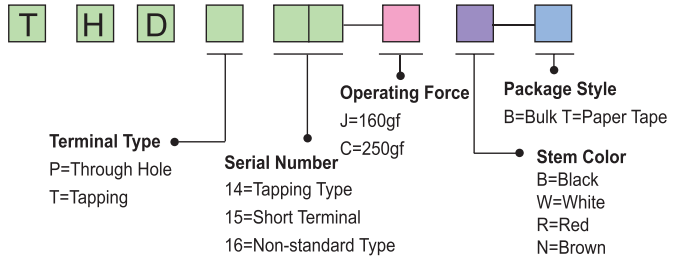

Specification

Items		Standard
Operating temperature range		-30℃ to +85℃
Electrical performance	Rating	50mA. 12V DC
	Insulation resistance	100MΩ min. 100V DC
	Dielectric strength	250V AC for 1 min.
	Contact resistance	100mΩ max.
Durability	Lifetime	A:300,000 Cycles J:C:100,000 Cycles
Mechanical performance	Operating force	J:160gf C:250gf
	Travel	0.25 ± 0.1mm

Diagram

No.	Dimensions	Circuit Diagram
		Pad Layout
1	<p>● THDT14</p>	
2	<p>● THDP15</p>	
3	<p>● THDP16</p>	

TACT SWITCH

6x6 SERIES

6.0x6.0 Radial Taping Type Tact Switch



TACT SWITCH

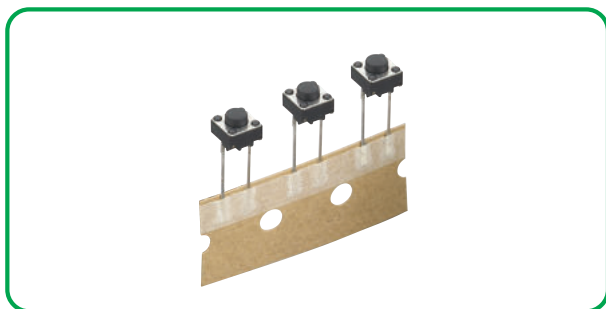

HOW TO ORDER

TVDT 17

Terminal Length
 =Standard Terminal
 A=3.5mm
 B=4.5mm
 C=5.5mm
 D=4.0mm

Switch Height
 043=4.3mm
 050=5.0mm
 055=5.5mm
 060=6.0mm
 065=6.5mm
 070=7.0mm

Operating Force
 A=90gf
 B=160gf
 C=250gf
 E=130gf

Stem Color
 B=Black
 W=White
 R=Red
 N=Brown

Package Style
 B=Bulk T=Paper Tape
Internal Dot Mark
 =Standard Life time
 1=High Lifetime
 2=Brass Cover
 3=High Lifetime & Brass Cover
 4=PET Cover
 5=High Lifetime & PET Cover

Specification

Items		Standard
Operating temperature range		-30°C to +85°C
Electrical performance	Rating	50mA. 12V DC
	Insulation resistance	100MΩ min. 100V DC
	Dielectric strength	250V AC for 1 min.
	Contact resistance	100mΩ max.
Durability	Lifetime	A:300,000 Cycles E:J:C:100,000 Cycles
Mechanical performance	Operating force	A:90gf J:160gf C:250gf E=130gf
	Travel	0.25 ± 0.1mm

Diagram

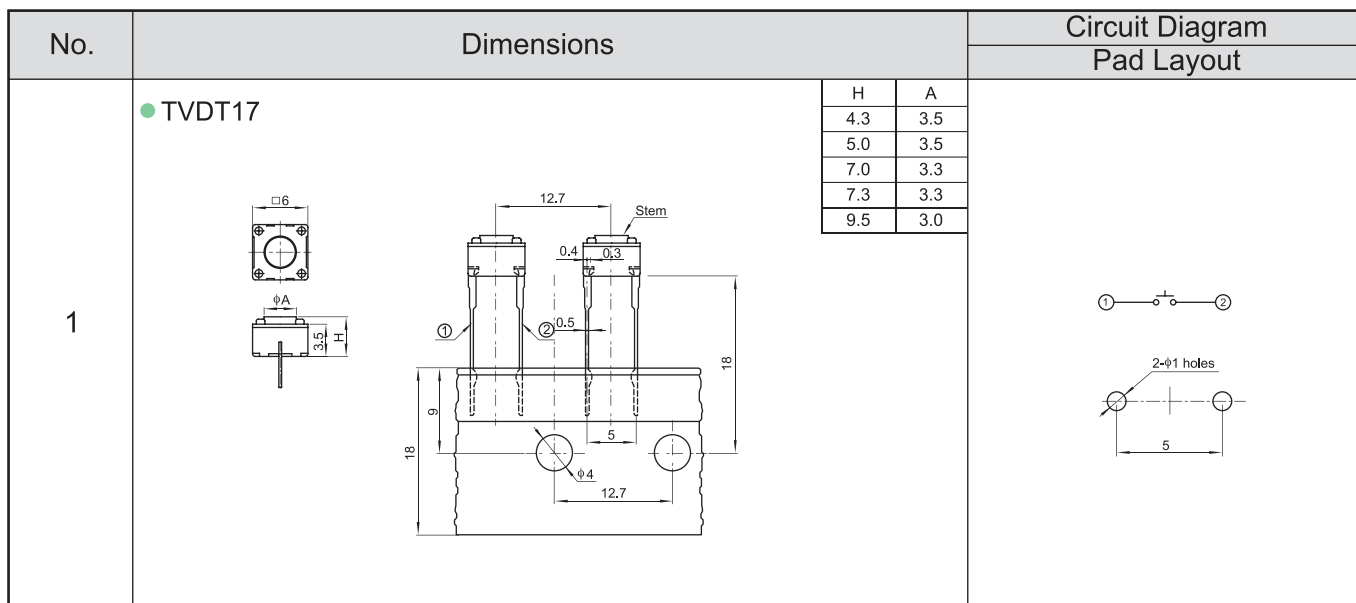

6x6 SERIES

6.0x6.0 Radial Taping Type Tact Switch

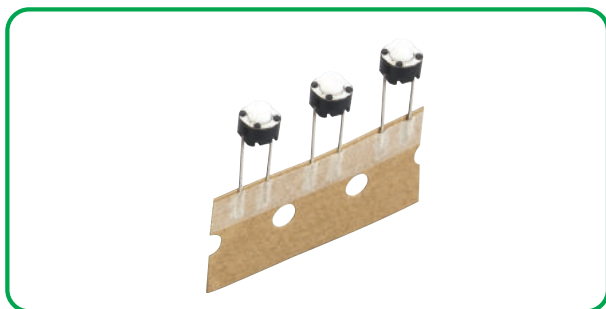

HOW TO ORDER

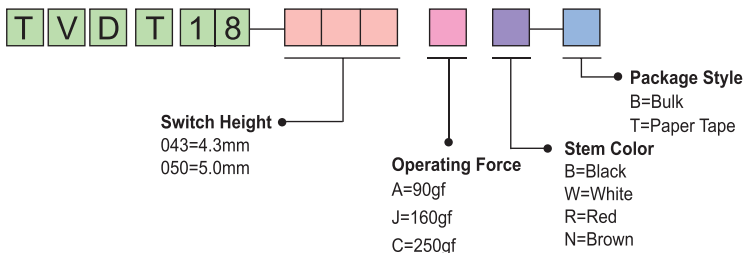

TACT SWITCH

Specification

Items		Standard
Operating temperature range		-30°C to +85°C
Electrical performance	Rating	50mA, 12V DC
	Insulation resistance	100MΩ min. 100V DC
	Dielectric strength	250V AC for 1 min.
	Contact resistance	100mΩ max.
Durability	Lifetime	A:300,000 Cycles J:C:100,000 Cycles
Mechanical performance	Operating force	A:90gf J:160gf C:250gf
	Travel	0.25 ± 0.1mm

Diagram

No.	Dimensions	Circuit Diagram						
		Pad Layout						
1	<p>● TVDT18</p> <table border="1" style="margin-left: auto; margin-right: auto;"> <tr> <td>H</td> <td>A</td> </tr> <tr> <td>4.3</td> <td>3.5</td> </tr> <tr> <td>5</td> <td>3.5</td> </tr> </table>	H	A	4.3	3.5	5	3.5	
H	A							
4.3	3.5							
5	3.5							

6x6 SERIES

9.1x7.3 Multiple Type Tact Switch



HOW TO ORDER

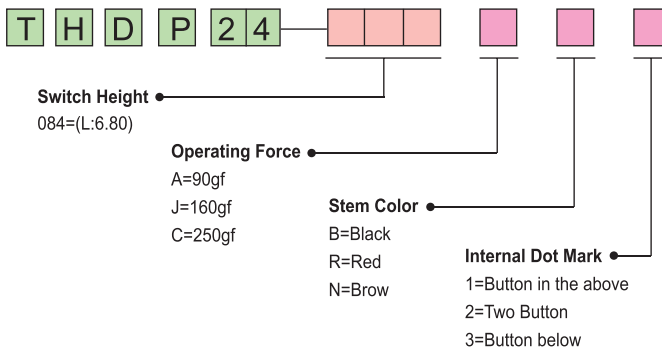

TACT SWITCH

Specification

Items		Standard
Operating temperature range		-30°C to +85°C
Electrical performance	Rating	50mA. 12V DC
	Insulation resistance	100MΩ min. 100V DC
	Dielectric strength	250V AC for 1 min.
	Contact resistance	100mΩ max.
Durability	Lifetime	100,000 Cycles min
Mechanical performance	Operating force	A:90gf J:160gf C:250gf
	Travel	0.20 ± 0.1mm

Diagram

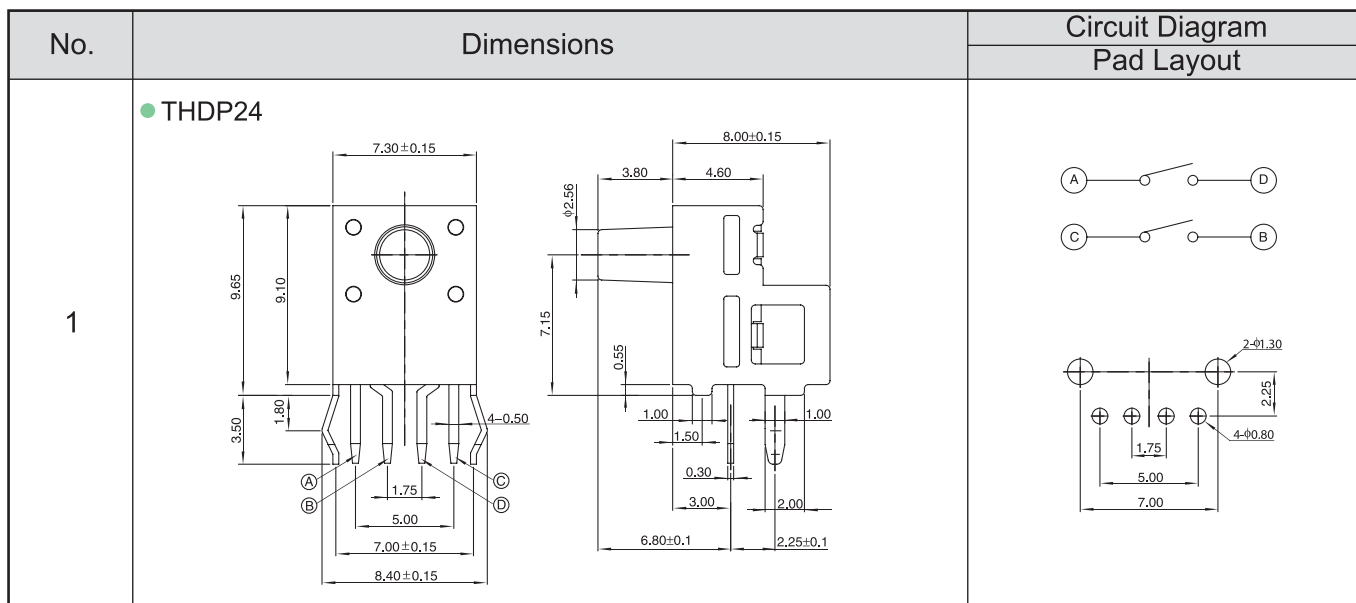

6x6 SERIES

6.0x6.0 Long Travel Tact Switch



HOW TO ORDER

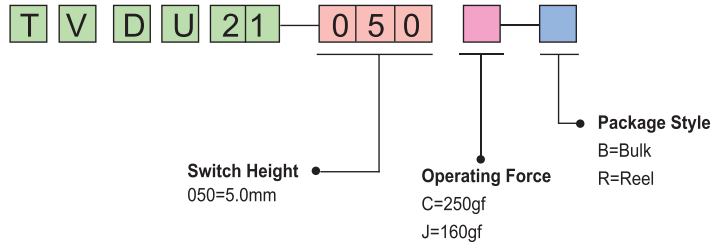

TACT SWITCH

Specification

Items		Standard
Operating temperature range		-40°C to +85°C
Electrical performance	Rating	50mA, 12V DC
	Insulation resistance	100MΩ min. 100V DC
	Dielectric strength	250V AC for 1 min.
	Contact resistance	100mΩ max.
Durability	Lifetime	J:C:100,000 Cycles
Mechanical performance	Operating force	J:160gf C:250gf
	Travel	1.30 ± 0.1mm

Diagram

No.	Dimensions	Circuit Diagram
		Pad Layout
1	<p>● TVDU21</p>	

6.2x6.2 SERIES

6.2x6.2 Flat & U-Type Terminals Type Tact Switch



TACT SWITCH

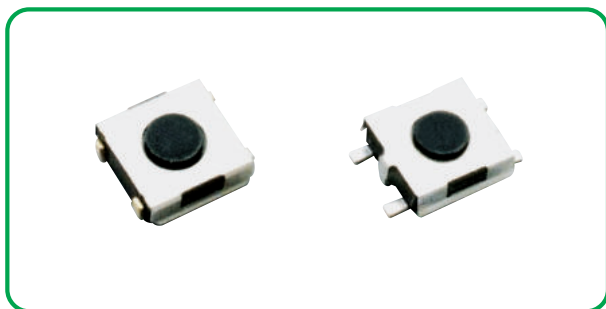

HOW TO ORDER

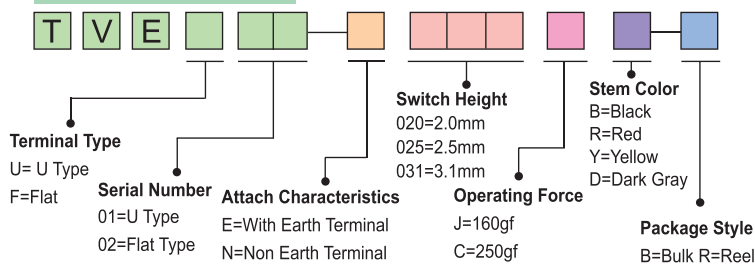

Specification

Items		Standard
Operating temperature range		-30°C to +85°C
Electrical performance	Rating	50mA. 12V DC
	Insulation resistance	100MΩ min. 100V DC
	Dielectric strength	250V AC for 1 min.
	Contact resistance	100mΩ max.
Durability	Lifetime	J:500,000 Cycles C:300,000 Cycles
Mechanical performance	Operating force	J:160gf C:250gf
	Travel	0.25 ± 0.1mm

Diagram

No.	Dimensions	Circuit Diagram						
		Pad Layout						
1	<p>● TVEU01</p>	<table border="1"> <tr><th>H</th></tr> <tr><td>3.1</td></tr> <tr><td>2.5</td></tr> <tr><td>2.0</td></tr> </table>	H	3.1	2.5	2.0		
			H					
3.1								
2.5								
2.0								
2	<p>● TVEF02</p>	<table border="1"> <tr><th>H</th></tr> <tr><td>3.1</td></tr> <tr><td>2.5</td></tr> <tr><td>2.0</td></tr> </table>	H	3.1	2.5	2.0		
			H					
3.1								
2.5								
2.0								

6.2x6.2 SERIES

6.2x6.2 Dust-Proof Type Tact Switch

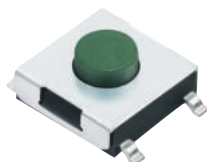

HOW TO ORDER

T V E M 04

Attach Characteristics

E=With Earth Terminal
N=Non Earth Terminal

Switch Height

031=3.1mm
050=5.0mm

Operating Force

J=160gf
C=250gf

Stem Color

B=Black
R=Red
G=Green
U=Blue

Package Style

B=Bulk R=Reel

TACT SWITCH

Specification

Items		Standard
Operating temperature range		-30°C to +85°C
Electrical performance	Rating	50mA. 12V DC
	Insulation resistance	100MΩ min. 100V DC
	Dielectric strength	250V AC for 1 min.
	Contact resistance	100mΩ max.
Durability	Lifetime	J:500,000 Cycles C:300,000 Cycles
Mechanical performance	Operating force	J:160gf C:250gf
	Travel	0.25 ± 0.1mm

Diagram

No.	Dimensions	Circuit Diagram
		Pad Layout
1	<p>● TVEM04</p>	

6.2x6.2 SERIES

6.2x6.2 SMT Terminals Type Tact Switch



TACT SWITCH

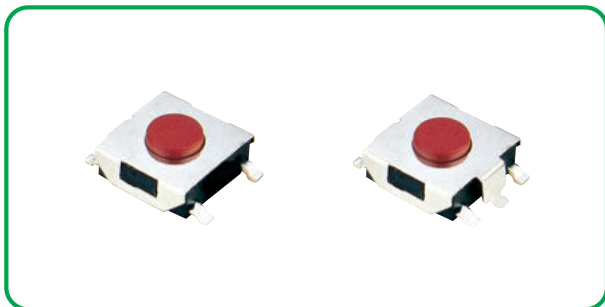

HOW TO ORDER

T V E M 0 5

Attach Characteristics

E=With Earth Terminal

N=Non Earth Terminal

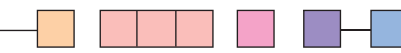

Switch Height

025=2.5mm

031=3.1mm

034=3.4mm

Operating Force

A=90gf

J=160gf

C=250gf

D=70gf

Stem Color

B=Black

R=Red

Package Style

B=Bulk

R=Reel

Specification

Items		Standard
Operating temperature range		-30°C to +85°C
Electrical performance	Rating	50mA, 12V DC
	Insulation resistance	100MΩ min. 100V DC
	Dielectric strength	250V AC for 1 min.
	Contact resistance	100mΩ max.
Durability	Lifetime	A:J:C:D:100,000 Cycles
Mechanical performance	Operating force	A:90gf J:160gf C:250gf D:70gf
	Travel	0.25 ± 0.1mm

Diagram

No.	Dimensions	Circuit Diagram					
		Pad Layout					
1	<p>● TVEM05-N</p>	<table border="1"> <tr><td>H</td></tr> <tr><td>3.4</td></tr> <tr><td>3.1</td></tr> <tr><td>2.5</td></tr> </table>	H	3.4	3.1	2.5	
H							
3.4							
3.1							
2.5							
2	<p>● TVEM05-E</p>	<table border="1"> <tr><td>H</td></tr> <tr><td>3.4</td></tr> <tr><td>3.1</td></tr> <tr><td>2.5</td></tr> </table>	H	3.4	3.1	2.5	
H							
3.4							
3.1							
2.5							

6.2x6.2 SERIES

6.2x6.2 Through Hole Terminals Type Tact Switch

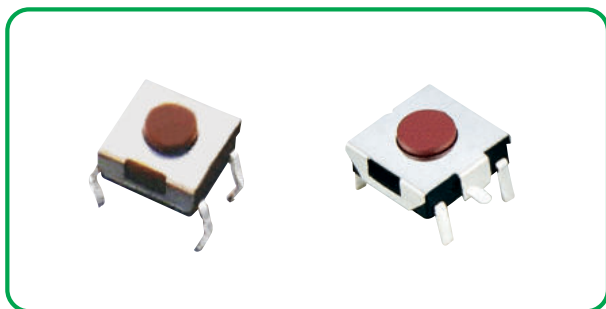

HOW TO ORDER

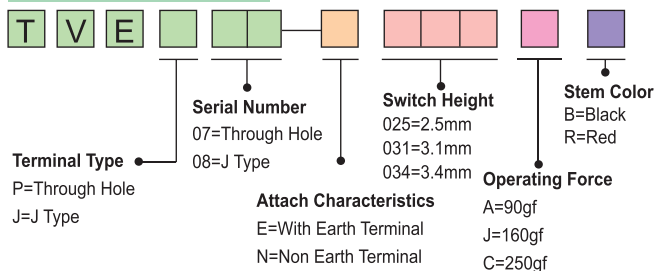

Specification

Items		Standard
Operating temperature range		-30°C to +85°C
Electrical performance	Rating	50mA. 12V DC
	Insulation resistance	100MΩ min. 100V DC
	Dielectric strength	250V AC for 1 min.
	Contact resistance	100mΩ max.
Durability	Lifetime	A:J:C=100,000 Cycles
Mechanical performance	Operating force	A:90gf J:160gf C:250gf
	Travel	0.25 ± 0.1mm

Diagram

No.	Dimensions	Circuit Diagram				
		Pad Layout				
1	<p>● TVEP07</p> <table border="1"> <tr><th>H</th></tr> <tr><td>3.4</td></tr> <tr><td>3.1</td></tr> <tr><td>2.5</td></tr> </table>	H	3.4	3.1	2.5	
H						
3.4						
3.1						
2.5						
2	<p>● TVEJ08</p> <table border="1"> <tr><th>H</th></tr> <tr><td>3.4</td></tr> <tr><td>3.1</td></tr> <tr><td>2.5</td></tr> </table>	H	3.4	3.1	2.5	
H						
3.4						
3.1						
2.5						

6.2x6.2 SERIES

6.2x6.2 With Middle-travel (SMT)Type Tact Switch



TACT SWITCH



HOW TO ORDER

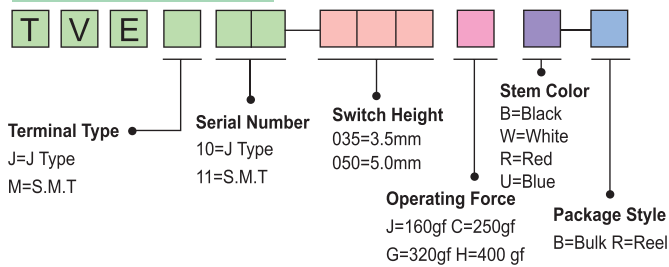

Specification

Items		Standard
Operating temperature range		-30°C to +85°C
Electrical performance	Rating	50mA. 12V DC
	Insulation resistance	100MΩ min. 100V DC
	Dielectric strength	250V AC for 1 min.
	Contact resistance	100mΩ max.
Durability	Lifetime	J:C:200,000 Cycles G:H:100,000 Cycles
Mechanical performance	Operating force	J:160gf C:250gf G:320gf H:400gf
	Travel	0.35 ± 0.1mm

Diagram

No.	Dimensions	Circuit Diagram
		Pad Layout
1	<p>● TVEJ10</p>	
2	<p>● TVEM11</p>	

6.2x6.2 SERIES

6.2x6.2 (J SMT)Series With Washable Type Tact Switch

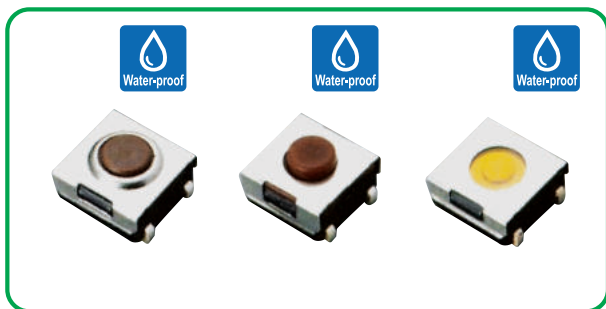

HOW TO ORDER

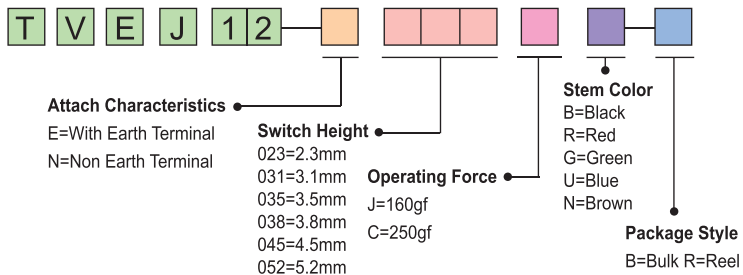

TACT SWITCH

Specification

Items		Standard
Operating temperature range		-30℃ to +85℃
Electrical performance	Rating	50mA. 12V DC
	Insulation resistance	100MΩ min. 100V DC
	Dielectric strength	250V AC for 1 min.
	Contact resistance	100mΩ max.
Durability	Lifetime	J:200,000 Cycles C:100,000 Cycles
Mechanical performance	Operating force	J:160gf C:250gf
	Travel	0.25 ± 0.1mm

Diagram

No.	Dimensions	Circuit Diagram
		Pad Layout
1	<p>● TVEJ12-□031</p>	
2	<p>● TVEJ12-□052</p>	
3	<p>● TVEJ12-□023</p>	

12x12 SERIES

12.0x12.0 Flat Stem With Stable Operation Feeling Tact Switch



TACT SWITCH

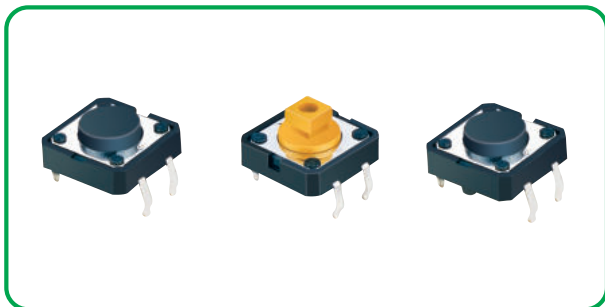

HOW TO ORDER

TVGP01

Attach Characteristics
 A=Base With Pilot
 □ =Non Pilot

Switch Height
 043=4.3mm
 050=5.0mm
 060=6.0mm
 070=7.0mm
 G73=7.3mm(Square)

Operating Force
 J=160gf
 C=250gf

Stem Color
 B=Black
 R=Red
 Y=Yellow
 N=Brown

Internal Dot Mark
 □ =Standard Lifetime
 1=High Lifetime
 2=Brass cover
 3=High Lifetime&Brass Cover
 4=PET Cover
 5=High Lifetime & PET Cover
 6=Base Without Slot

Specification

Items		Standard
Operating temperature range		-30°C to +85°C
Electrical performance	Rating	50mA. 12V DC
	Insulation resistance	100MΩ min. 100V DC
	Dielectric strength	250V AC for 1 min.
	Contact resistance	100mΩ max.
Durability	Lifetime	J:200,000 Cycles C:100,000 Cycles
Mechanical performance	Operating force	J:160gf C:250gf
	Travel	0.35 ± 0.1mm

Diagram

No.	Dimensions	Circuit Diagram
		Pad Layout
1	<p>● TVGP01</p>	
2	<p>● TVGP01-□ G73</p>	
3	<p>● TVGP01-A</p>	

12x12 SERIES

12.0x12.0 Flat Stem With Stable Operation Feeling Tact Switch



HOW TO ORDER

T V G M 0 3

- Attach Characteristics**
 - A=Base With Pilot
 - =Non Pilot
- Switch Height**
 - 043=4.3mm
 - 050=5.0mm
 - 060=6.0mm
 - 070=7.0mm
 - G73=7.3mm(Square)
- Operating Force**
 - J=160gf
 - C=250gf
- Stem Color**
 - B=Black
 - R=Red
 - N=Brown
- Package Style**
 - B=Bulk
 - R=Reel
 - U=Tube
- Internal Dot Mark**
 - =Standard Lifetime
 - 1=High Lifetime
 - 6=Base Without Slot

TACT SWITCH

Specification

Items		Standard
Operating temperature range		-30°C to +85°C
Electrical performance	Rating	50mA. 12V DC
	Insulation resistance	100MΩ min. 100V DC
	Dielectric strength	250V AC for 1 min.
	Contact resistance	100mΩ max.
Durability	Lifetime	J:200,000 Cycles C:100,000 Cycles
Mechanical performance	Operating force	J:160gf C:250gf
	Travel	0.35 ± 0.1mm

Diagram

No.	Dimensions	Circuit Diagram
		Pad Layout
1	<p>● TVGM03</p>	

WASHABLE SERIES

6.0x6.0 Washable Tact Switch



TACT SWITCH



HOW TO ORDER

T V J P [Color Swatches]

- Serial Number**
13=Standard
16=With A Sheath
- Switch Height**
043=4.3mm
045=4.5mm
050=5.0mm
055=5.5mm
060=6.0mm
065=6.5mm
070=7.0mm
- Operating Force**
J=160gf
C=250gf
- Stem color**
R=Red
B=Black

Specification

Items		Standard
Operating temperature range		-30°C to +85°C
Electrical performance	Rating	50mA, 12V DC
	Insulation resistance	100MΩ min. 100V DC
	Dielectric strength	250V AC for 1 min.
	Contact resistance	100mΩ max.
Durability	Lifetime	J:C:100,000 Cycles
Mechanical performance	Operating force	J:160gf C:250gf
	Travel	0.25 ± 0.1mm

Diagram

No.	Dimensions	Circuit Diagram	
		Pad Layout	
1	<p>● TVJP13</p>	H	
		4.3	
		5.0	
		5.5	
		6.0	
		6.5	
		7.0	
		7.5	
		8.0	
		8.5	
9.0			
9.5			
2	<p>● TVJP16</p>	H	
		8	
		8.5	
		9	
		9.5	
		...	

WATERPROOF SERIES

6.0x6.0 Washable Tact Switch



HOW TO ORDER

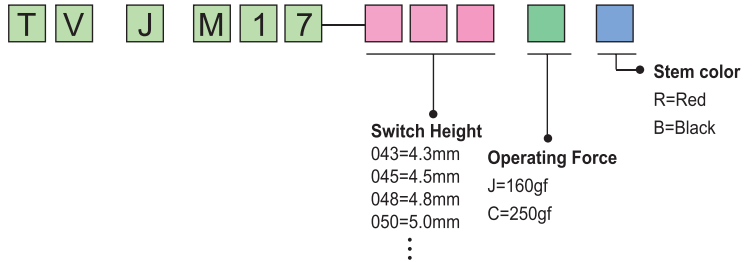

TACT SWITCH

Specification

Items		Standard
Operating temperature range		-25°C to +85°C
Electrical performance	Rating	100mA. 30V DC
	Insulation resistance	100MΩ min. 100V DC
	Dielectric strength	AC500V(50Hz) for 1 min.
	Contact resistance	50mΩ max.
Durability	Lifetime	J:C:100.000 Cycles
Mechanical performance	Operating force	J:160gf C:250g
	Travel	0.25 ± 0.1mm

Diagram

No.	Dimensions	Circuit Diagram							
		Pad Layout							
1	<p>● TVJM17</p>	<table border="1"> <tr><td>H</td></tr> <tr><td>4.3</td></tr> <tr><td>4.5</td></tr> <tr><td>4.8</td></tr> <tr><td>5</td></tr> <tr><td>...</td></tr> </table>	H	4.3	4.5	4.8	5	...	
H									
4.3									
4.5									
4.8									
5									
...									

WASHABLE SERIES

8.0x8.0 Washable Tact Switch



TACT SWITCH

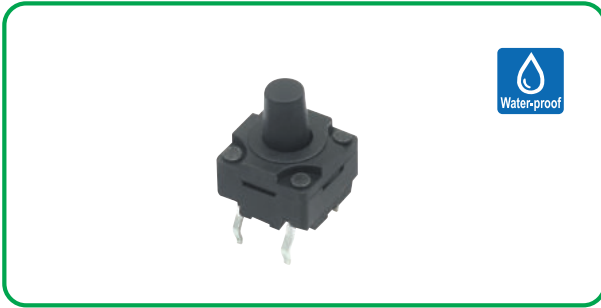

HOW TO ORDER

T V J P 1 4

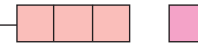

Switch Height

- 065=6.5mm
- 070=7.0mm
- 075=7.5mm
- 080=8.0mm
- 085=8.5mm

Operating Force

- J=160gf
- C=250gf

Specification

Items		Standard
Operating temperature range		-30℃ to +85℃
Electrical performance	Rating	50mA, 12V DC
	Insulation resistance	100MΩ min. 100V DC
	Dielectric strength	250V AC for 1 min.
	Contact resistance	100mΩ max.
Durability	Lifetime	J:C:100,000 Cycles
Mechanical performance	Operating force	J:160gf C:250gf
	Travel	0.25 ± 0.1mm

Diagram

No.	Dimensions	Circuit Diagram													
		Pad Layout													
1	<p>● TVJP14</p>	<table border="1"> <thead> <tr> <th>H</th> </tr> </thead> <tbody> <tr><td>6.5</td></tr> <tr><td>7.0</td></tr> <tr><td>7.5</td></tr> <tr><td>8.0</td></tr> <tr><td>8.5</td></tr> <tr><td>9.0</td></tr> <tr><td>9.5</td></tr> <tr><td>11.0</td></tr> <tr><td>12.0</td></tr> <tr><td>13.0</td></tr> </tbody> </table>	H	6.5	7.0	7.5	8.0	8.5	9.0	9.5	11.0	12.0	13.0		
			H												
6.5															
7.0															
7.5															
8.0															
8.5															
9.0															
9.5															
11.0															
12.0															
13.0															

WASHABLE SERIES

10.0x10.0 Washable Tact Switch

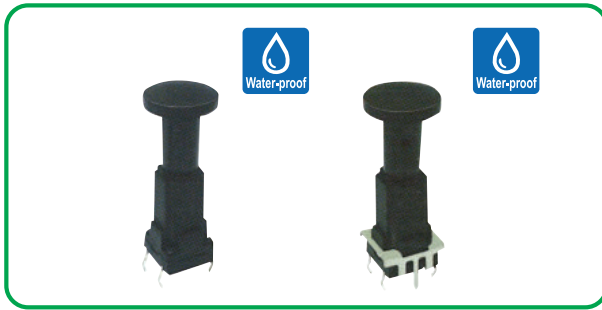

HOW TO ORDER

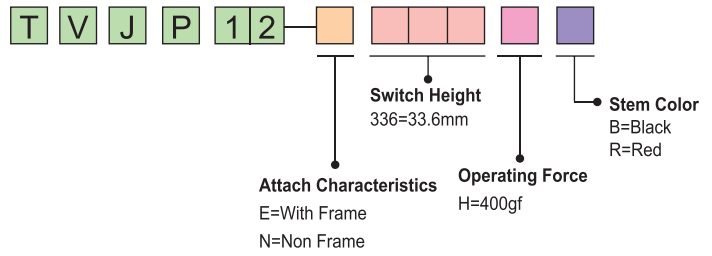

Specification

Items		Standard
Operating temperature range		-20°C to +70°C
Electrical performance	Rating	50mA, 12V DC
	Insulation resistance	100MΩ min. 100V DC
	Dielectric strength	250V AC for 1 min.
	Contact resistance	100mΩ max.

Items		Standard
Durability	Lifetime	100,000 Cycles Min
Mechanical performance	Operating force	H:400gf ± 70gf
	Travel	0.40 ± 0.2mm

Water Resisting Performance

Items	Model	Vertical type	Horizontal type
Temperature of water		60°C	60°C
Depth of water		10cm	10cm
Immersion duration		240h	1h

Diagram

No.	Dimensions	Circuit Diagram
		Pad Layout
1	<p>● TVJP12-N</p>	
2	<p>● TVJP12-E</p>	

TACT SWITCH

WASHABLE SERIES

10.0x10.0 Washable Tact Switch



TACT SWITCH

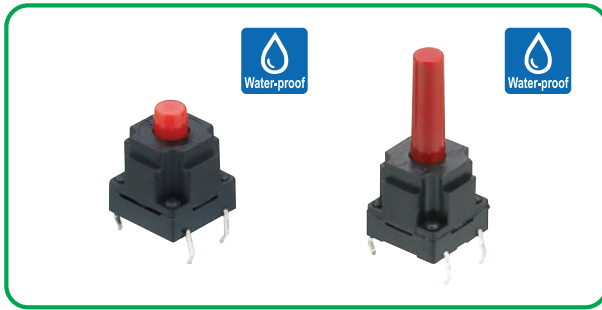

HOW TO ORDER

T V J P 1 1

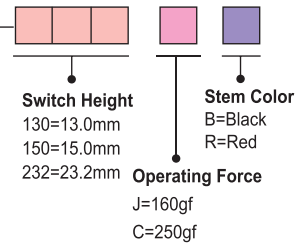

Specification

Items		Standard
Operating temperature range		-40°C to +90°C
Electrical performance	Rating	50mA, 12V DC
	Insulation resistance	100MΩ min. 100V DC
	Dielectric strength	250V AC for 1 min.
	Contact resistance	500mΩ max.
Durability	Lifetime	100,000 Cycles Min
Mechanical performance	Operating force	J:160gf C:250gf
	Travel	0.30 ± 0.1mm

Water Resisting Performance

Temperature of water	60°C
Depth of water	10cm
Immersion duration	240h

Diagram

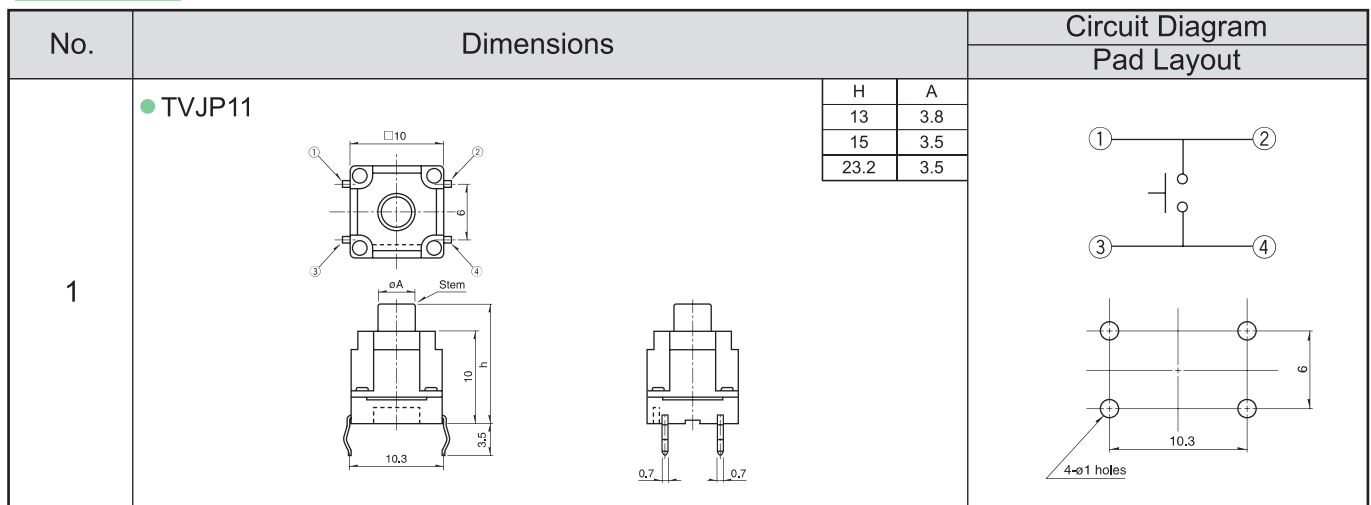

WASHABLE SERIES

10.0x10.0 Washable Tact Switch



HOW TO ORDER

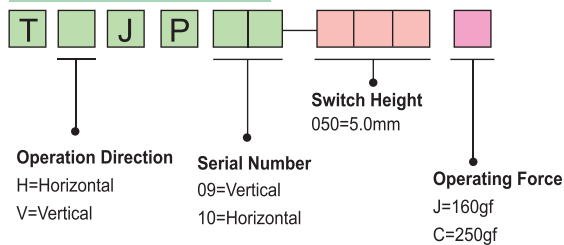

Specification

Items		Standard	Items		Standard
Operating temperature range		-40°C to +90°C	Durability	Lifetime	100,000 Cycles Min
Electrical performance	Rating	50mA, 12V DC	Mechanical performance	Operating force	J:160gf C:250gf
	Insulation resistance	100MΩ min. 100V DC		Travel	0.30 ± 0.1mm
	Dielectric strength	250V AC for 1 min.			
	Contact resistance	500mΩ max.			

Water Resisting Performance

Items	Model	Vertical type	Horizontal type
Temperature of water		60°C	60°C
Depth of water		10cm	10cm
Immersion duration		240h	1h

Diagram

No.	Dimensions	Circuit Diagram Pad Layout
1	<p>● TVJP09</p>	

TACT SWITCH

WASHABLE SERIES

12x12 Washable Tact Switch



HOW TO ORDER

T V J P 15

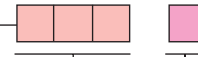

Switch Height

- 065=6.5mm
- 070=7.0mm
- 075=7.5mm
- 080=8.0mm
- 085=8.5mm

Operating Force

- J=160gf
- C=250gf

Specification

Items		Standard
Operating temperature range		-30°C to +85°C
Electrical performance	Rating	50mA, 12V DC
	Insulation resistance	100MΩ min. 100V DC
	Dielectric strength	250V AC for 1 min.
	Contact resistance	100mΩ max.
Durability	Lifetime	J:C:100,000 Cycles
Mechanical performance	Operating force	J:160gf C:250gf
	Travel	0.25 ± 0.1mm

Diagram

No.	Dimensions	Circuit Diagram	
		Pad Layout	
1	<ul style="list-style-type: none"> ● TVJP15 	H	
		6.5	
		7.0	
		7.5	
		8.0	
		8.5	
		9.0	
		9.5	
		10.0	
		11.0	
12.0			

02

MULTI-FUNCTION SWITCH SERIES

Features:

- Sharp click feel with a positive tactile feedback.
- Ultraminiature and light weight structure suitable for high density mounting, economical but reliable.
- Insert molding in the contact with special treatment prevents flux build-up during soldering and permits auto-dipping.

Applications:

- Cameras, digital still cameras.
- Digital video camcorders.
- Compact portable devices.
- For operating the other multifunctional electronic devices



MULTI FUNCTION SERIES

6.2x6.5 Double Action Type Tact Switch



HOW TO ORDER

T M H F 0 7

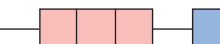

Switch Height
038=3.8mm
020=2.0mm(Non Stem)

Package Style
B=Bulk
R=Reel

Specification

Items		Standard
Operating temperature range		-30°C to +85°C
Electrical performance	Rating	50mA, 12V DC
	Insulation resistance	100MΩ min. 100V DC
	Dielectric strength	250V AC for 1 min.
	Contact resistance	100mΩ max.
Durability	Lifetime	10,000 Cycles
Mechanical performance	Operating force	1 st 100 ± 40gf 2 st 250 ± 80gf
	Travel	1 st 0.3 ± 0.1mm 2 st 0.55 ± 0.1mm

Diagram

No.	Dimensions	Circuit Diagram Pad Layout
1	<p>● TMHF07</p>	

MULTI FUNCTION SERIES

6.1x6.5 4-direction & center-push Tact Switch

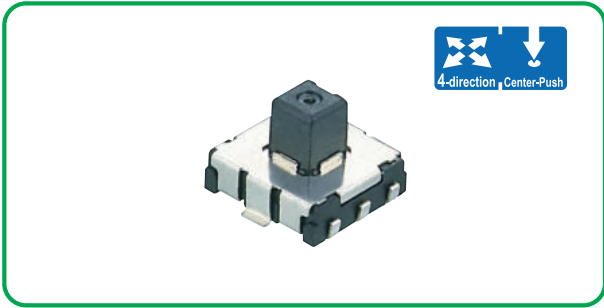

HOW TO ORDER

T M H U 1 2

Attach Characteristics
 □ = Base With Pilot
 N = Non Pilot



Stem Color
 B = Black
 N = Brow

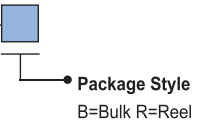

Package Style
 B = Bulk R = Reel

Stem Type
 A = Stem Without a Slot
 B = Stem With a Slot

Specification

Items		Standard
Operating temperature range		-30°C to +85°C
Electrical performance	Rating	50mA, 12V DC
	Insulation resistance	100MΩ min. 100V DC
	Dielectric strength	250V AC for 1 min.
	Contact resistance	4-direction 200mΩ max Center push 100mΩ max.
Durability	Lifetime	50,000 Cycles
Mechanical performance	Operating force	4-direction 140 ± 50gf Center push 220 ± 80gf
	Travel	4-direction 5° ± 2° Center push 0.20 ± 0.1mm

Diagram

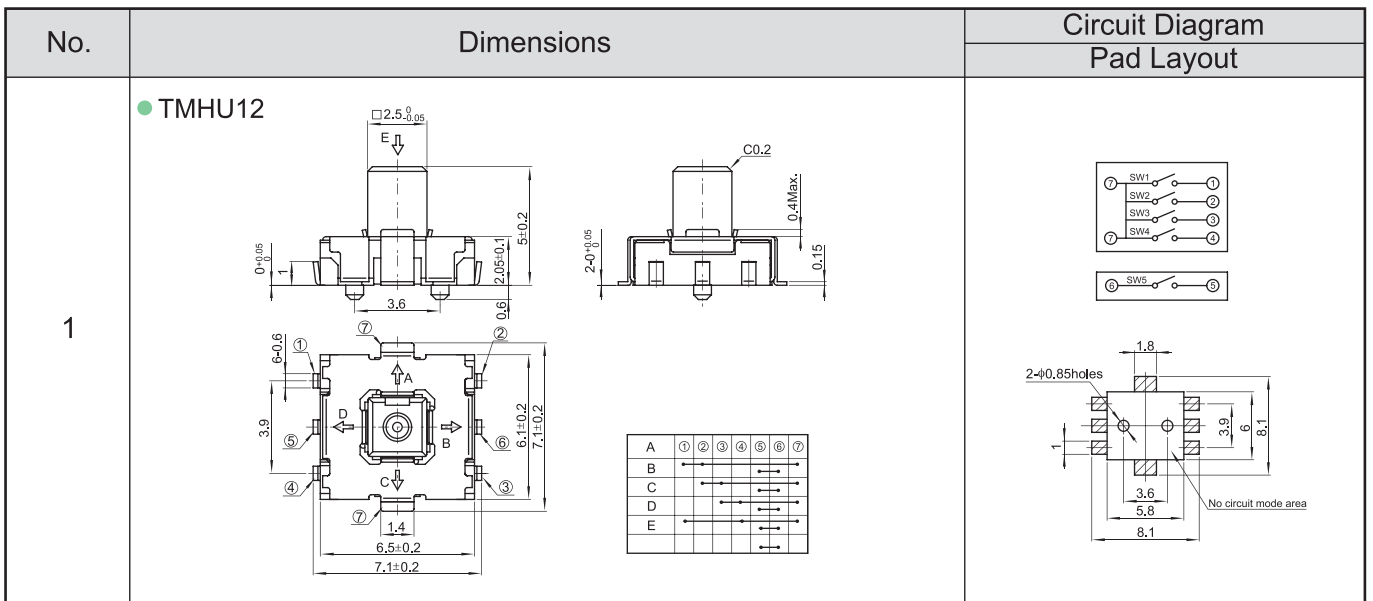

MULTI FUNCTION SERIES

7.5x7.5 4-direction & center-push Tact Switch

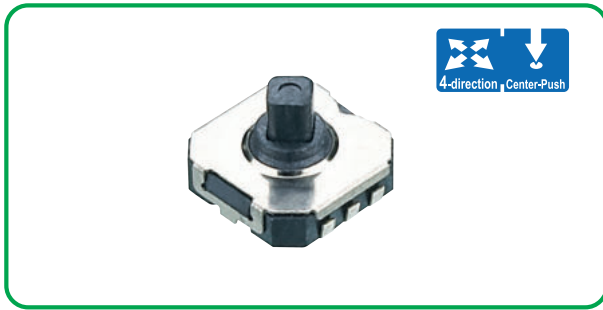

HOW TO ORDER

T M H U 1 3

Attach Characteristics
 □ = Base With Pilot
 N = Non Pilot

Stem Color
 B = Black
 W = White

Package Style
 B = Bulk
 R = Reel

Specification

Items		Standard	
Operating temperature range		-30°C to +85°C	
Electrical performance	Rating	50mA. 12V DC	
	Insulation resistance	100MΩ min. 100V DC	
	Dielectric strength	250V AC for 1 min.	
	Contact resistance	500mΩ max.	
Durability	Lifetime	50,000 Cycles	
Mechanical performance	Operating force	4-direction 160 ± 50gf	Center push 280 ± 100gf
	Travel	4-direction 0.20 ± 0.1mm	Center push 0.15 ± 0.1mm

Diagram

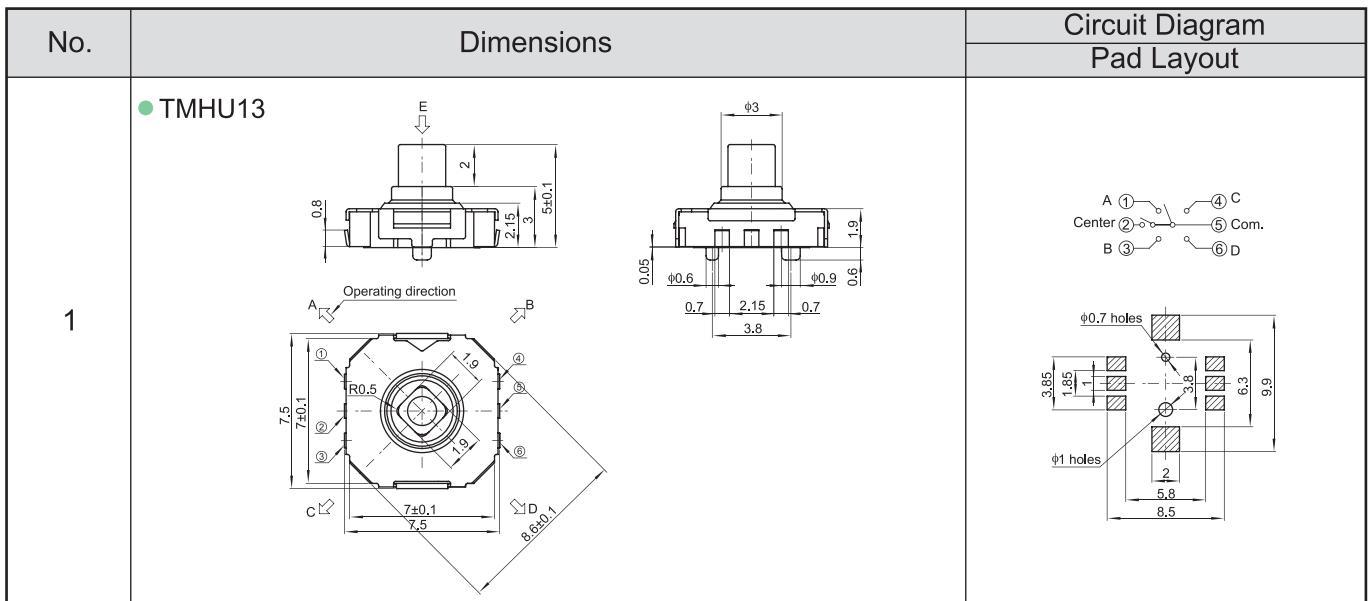

MULTI FUNCTION SERIES

10.0x10.4 4-direction & center-push Tact Switch



HOW TO ORDER

T M H M 1 4

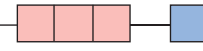

Package Style
 B=Bulk
 R=Reel

Switch Height
 050=5.0mm

Specification

Items		Standard
Operating temperature range		-30°C to +85°C
Electrical performance	Rating	20mA, 12V DC
	Insulation resistance	100MΩ min. 100V DC
	Dielectric strength	250V AC for 1 min.
	Contact resistance	100mΩ max.
Durability	Lifetime	50,000 Cycles
Mechanical performance	Operating force	4-direction 160 ± 80gf Center push 300 ± 150gf
	Travel	4-direction 4° ± 2° Center push 0.20 ± 0.1mm

Diagram

No.	Dimensions	Circuit Diagram Pad Layout
1	<p>● TMHM14</p>	

MULTI FUNCTION SERIES

10.0x10.7 4-direction & center-push Tact Switch

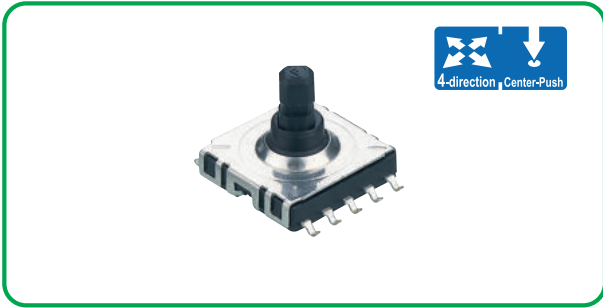

HOW TO ORDER

T M H M 1 6

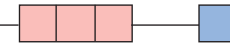

• **Switch Height**
 050=5.0mm
 065=6.5mm
 090=9.0mm

• **Package Style**
 B=Bulk R=Reel

Specification

Items		Standard	
Operating temperature range		-30°C to +85°C	
Electrical performance	Rating	20mA, 12V DC	
	Insulation resistance	100MΩ min. 100V DC	
	Dielectric strength	250V AC for 1 min.	
	Contact resistance	100mΩ max.	
Durability	Lifetime	50,000 Cycles	
Mechanical performance	Operating force	4-direction 160 ± 80gf	Center push 300 ± 150gf
	Travel	4-direction 4° ± 2°	Center push 0.20 ± 0.1mm

Diagram

No.	Dimensions	Circuit Diagram Pad Layout
1	<p>● TMHM16</p> <p>Top view dimensions: 10.7, 10, 1.4, 45°, 45°, 1.4, 0.5, 0.8, 2, 2, 2, 2, 2, 2, 2, 2, 4-C0.5, B, C, D, a, d, e, c, b, G1, G2.</p> <p>Side view dimensions: 6.5, 4, 2.83, 0.8, 0.5, 2.3, 1.2, PIVOT, 2-C0.1, 2-0.8.</p> <p>Detail view dimensions: Ø0.7, 2.5, 1.5, C.2, R0.1.</p>	<p>Circuit diagram shows a center push (e) and four directions (a, b, c, d) connected to terminals G1 and G2. Labels A, B, C, D are also present.</p> <p>Pad layout dimensions: 2, 10.6, 0.8, 2, 8, 9.8, 45°, 2-Ø1.</p>

MULTI-FUNCTION SWITCH

MULTI FUNCTION SERIES

Lever and Push Operation Type Switch Tact Switch



Specification

Items		Standard
Operating temperature range		-30°C to +85°C
Electrical performance	Rating	10mA, 5V DC
	Output voltage	1V max. at 1mA 5V DC
	Contact resistance	100mΩ max.
	Lifetime	100,000 Cycles
Durability	Operating force	Lever portion 70 ± 40gf Push portion 200 ± 100gf
Mechanical performance	Travel	4-direction -25° - 0° - +25°
		Push portion 0.90 ± 0.1mm

Diagram

No.	Dimensions	Circuit Diagram																														
		Pad Layout																														
1	<p>● TMHU26</p> <p>Code table</p> <table border="1"> <tr> <td>Angle</td> <td>25°</td> <td>CW</td> <td>0°</td> <td>CCW</td> <td>25°</td> </tr> <tr> <td>Terminal</td> <td>(18°)</td> <td></td> <td></td> <td>(18°)</td> <td></td> </tr> <tr> <td>①</td> <td></td> <td></td> <td></td> <td></td> <td></td> </tr> <tr> <td>②</td> <td></td> <td></td> <td></td> <td></td> <td></td> </tr> <tr> <td>ⓐ</td> <td></td> <td></td> <td></td> <td></td> <td></td> </tr> </table>	Angle	25°	CW	0°	CCW	25°	Terminal	(18°)			(18°)		①						②						ⓐ						
Angle	25°	CW	0°	CCW	25°																											
Terminal	(18°)			(18°)																												
①																																
②																																
ⓐ																																
2	<p>● TMHU27</p> <p>Code table</p> <table border="1"> <tr> <td>Angle</td> <td>25°</td> <td>CW</td> <td>0°</td> <td>CCW</td> <td>25°</td> </tr> <tr> <td>Terminal</td> <td>(18°)</td> <td></td> <td></td> <td>(18°)</td> <td></td> </tr> <tr> <td>①</td> <td></td> <td></td> <td></td> <td></td> <td></td> </tr> <tr> <td>②</td> <td></td> <td></td> <td></td> <td></td> <td></td> </tr> <tr> <td>ⓐ</td> <td></td> <td></td> <td></td> <td></td> <td></td> </tr> </table>	Angle	25°	CW	0°	CCW	25°	Terminal	(18°)			(18°)		①						②						ⓐ						
Angle	25°	CW	0°	CCW	25°																											
Terminal	(18°)			(18°)																												
①																																
②																																
ⓐ																																

MULTI FUNCTION SERIES

Lever and Push Operation Type Switch Tact Switch

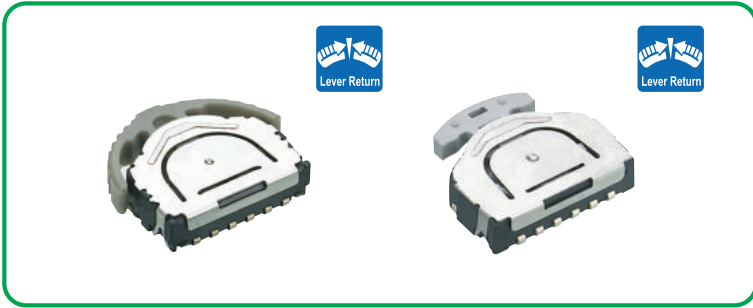

Specification

Items		Standard
Operating temperature range		-30°C to +85°C
Electrical performance	Rating	10mA, 5V DC
	Output voltage	1V max. at 1mA 5V DC
	Contact resistance	100mΩ max.
	Lifetime	100,000 Cycles
Durability	Operating force	Lever portion 70 ± 40gf Push portion 200 ± 100gf
Mechanical performance	Travel	4-direction -25° -0° - +25°
		Push portion 0.85 ± 0.1mm

Diagram

No.	Dimensions		Circuit Diagram																												
	TMHU28	TMHU29	Pad Layout																												
1																															
<p>Code table</p> <table border="1"> <thead> <tr> <th>Angle</th> <th>25° } CW</th> <th>0°</th> <th>CCW 25° }</th> </tr> <tr> <th>Terminal</th> <th>(21.5°) (11°)</th> <th>(11°) (21.5°)</th> <th></th> </tr> </thead> <tbody> <tr> <td>①</td> <td>▨</td> <td></td> <td></td> </tr> <tr> <td>②</td> <td>▨</td> <td></td> <td></td> </tr> <tr> <td>③</td> <td></td> <td>▨</td> <td></td> </tr> <tr> <td>④</td> <td></td> <td>▨</td> <td></td> </tr> <tr> <td>Ⓢ</td> <td>▨</td> <td>▨</td> <td></td> </tr> </tbody> </table>			Angle	25° } CW	0°	CCW 25° }	Terminal	(21.5°) (11°)	(11°) (21.5°)		①	▨			②	▨			③		▨		④		▨		Ⓢ	▨	▨		
Angle	25° } CW	0°	CCW 25° }																												
Terminal	(21.5°) (11°)	(11°) (21.5°)																													
①	▨																														
②	▨																														
③		▨																													
④		▨																													
Ⓢ	▨	▨																													

MULTI FUNCTION SERIES

Lever and Push Operation Type Switch Tact Switch



MULTI-FUNCTION SWITCH

Specification

Items		Standard
Operating temperature range		-30°C to +85°C
Electrical performance	Rating	10mA, 5V DC
	Output voltage	1V max. at 1mA 5V DC
	Contact resistance	100mΩ max.
	Lifetime	100,000 Cycles
Durability	Operating force	Lever portion 70 ± 40gf Push portion 250 ± 100gf
Mechanical performance	Travel	4-direction -20° -0° - +20°
		Push portion 0.70 ± 0.1mm

Diagram

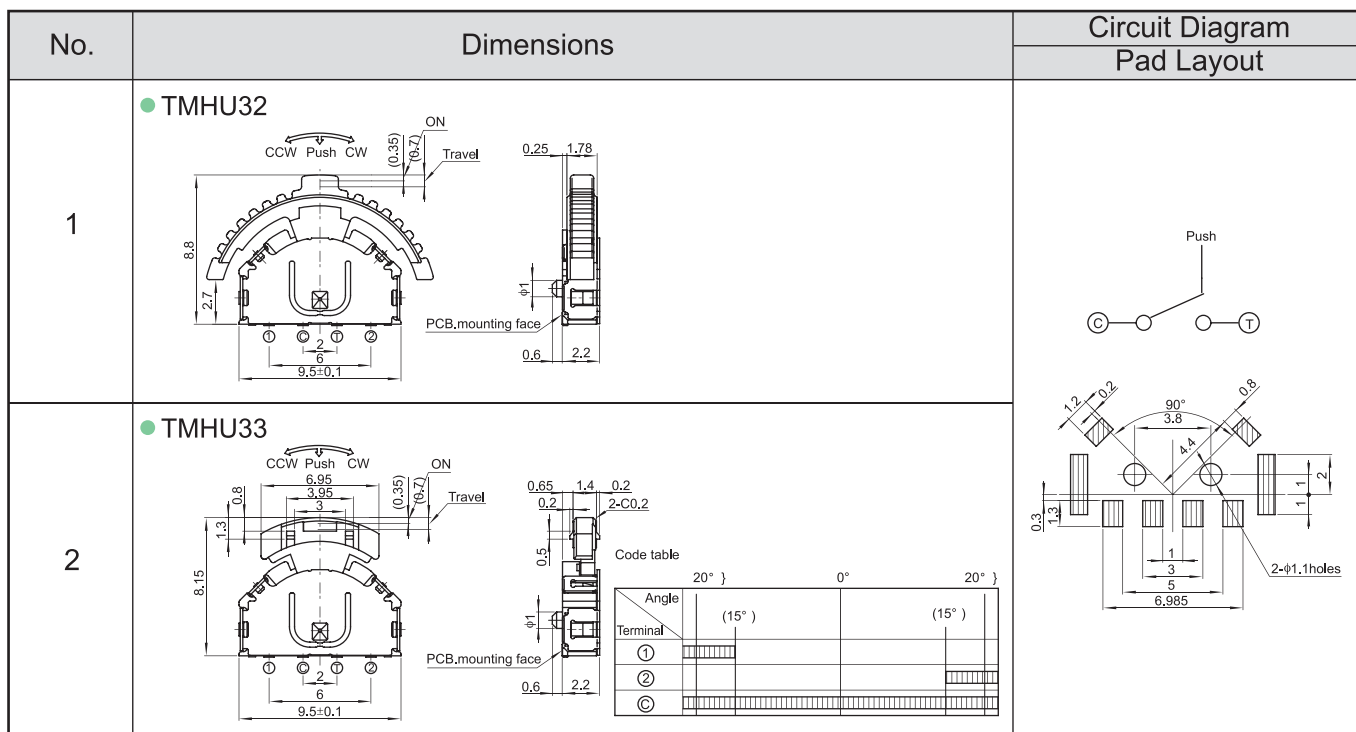

LIGHT SWITCH SERIES

03

Features:

- With a fixed stand and covers in many kinds of structure and color;
- High sensitive sounds silvery, feeling and rythm are perfect.
- It can be mounted with any color LED and bouble colors or 3 colors LED according to preference.
- It can be assembled in different ways: DIP & SMT, with pushbutton an tact for operating.
- We have got some patent for new project.

Applications:

The switches work with all kinds of electrical appliances, such as audio apparatus, office equipment, instruments and meter equipment, TV, DVD, and so on.

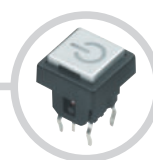
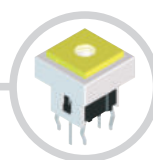
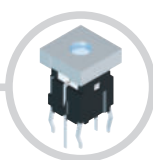
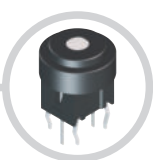

LAMP SERIES

6x6 Led Built-in Type

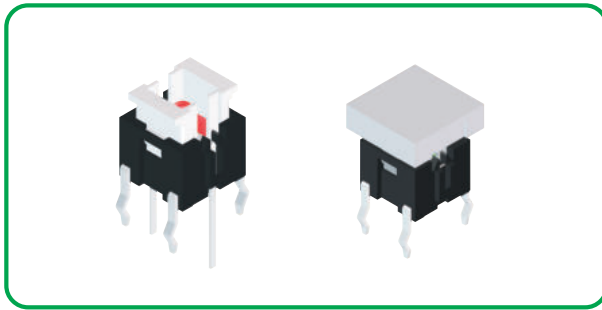

HOW TO ORDER

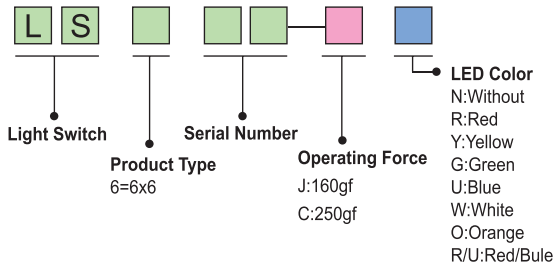

Specification

Items		Standard
Operating temperature range		-25°C to +85°C
Electrical performance	Rating	50mA, 30V DC
	Insulation resistance	100MΩ min. 250V DC
	Dielectric strength	AC250V(50-60Hz) for 1 min.
	Contact resistance	100mΩ max.
Durability	Lifetime	100,000 Cycles Min
Mechanical performance	Operating force	J:160gf C:250gf
	Travel	0.25 ± 0.1mm

Diagram

No.	Dimensions	Circuit Diagram																																				
		Pad Layout																																				
1	<p>● LS601</p> <table border="1"> <thead> <tr> <th>Color</th> <th>VR</th> <th>IF</th> <th>Recommended Operating</th> <th>IF Nom</th> <th>IF Max</th> </tr> </thead> <tbody> <tr> <td>White</td> <td>DC5V</td> <td>20mA</td> <td>20mA</td> <td>3.0V</td> <td>3.6V</td> </tr> <tr> <td>Red</td> <td>DC5V</td> <td>20mA</td> <td>20mA</td> <td>1.7V</td> <td>2.4V</td> </tr> <tr> <td>Yellow</td> <td>DC5V</td> <td>20mA</td> <td>20mA</td> <td>1.9V</td> <td>2.4V</td> </tr> <tr> <td>Blue</td> <td>DC5V</td> <td>20mA</td> <td>20mA</td> <td>3.0V</td> <td>3.6V</td> </tr> <tr> <td>Green</td> <td>DC5V</td> <td>20mA</td> <td>20mA</td> <td>1.9V</td> <td>2.4V</td> </tr> </tbody> </table>	Color	VR	IF	Recommended Operating	IF Nom	IF Max	White	DC5V	20mA	20mA	3.0V	3.6V	Red	DC5V	20mA	20mA	1.7V	2.4V	Yellow	DC5V	20mA	20mA	1.9V	2.4V	Blue	DC5V	20mA	20mA	3.0V	3.6V	Green	DC5V	20mA	20mA	1.9V	2.4V	<p>Circuit Diagram</p> <p>PCB Layout Recommended</p>
Color	VR	IF	Recommended Operating	IF Nom	IF Max																																	
White	DC5V	20mA	20mA	3.0V	3.6V																																	
Red	DC5V	20mA	20mA	1.7V	2.4V																																	
Yellow	DC5V	20mA	20mA	1.9V	2.4V																																	
Blue	DC5V	20mA	20mA	3.0V	3.6V																																	
Green	DC5V	20mA	20mA	1.9V	2.4V																																	
2	<p>● LS602</p>	<p>Circuit Diagram</p> <p>PCB Layout Recommended</p>																																				

LAMP SERIES

6x6 Led Built-in Type

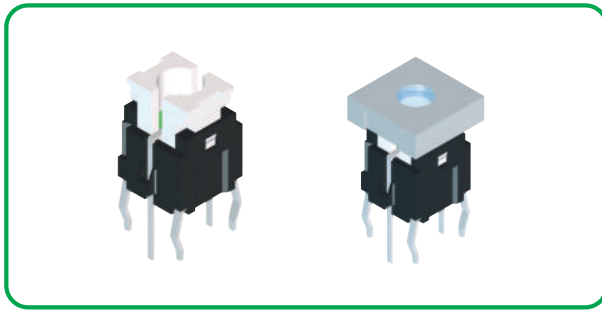

HOW TO ORDER

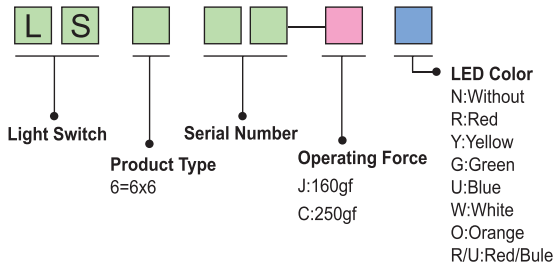

Specification

Items		Standard
Operating temperature range		-25°C to +85°C
Electrical performance	Rating	50mA, 30V DC
	Insulation resistance	100MΩ min. 250V DC
	Dielectric strength	AC250V(50-60Hz) for 1 min.
	Contact resistance	100mΩ max.
Durability	Lifetime	100,000 Cycles Min
Mechanical performance	Operating force	J:160gf C:250gf
	Travel	0.25 ± 0.1mm

Diagram

No.	Dimensions	Circuit Diagram																																				
		Pad Layout																																				
1	<p>● LS605</p> <table border="1"> <thead> <tr> <th>Color</th> <th>VR</th> <th>IF</th> <th>Recommended Operating</th> <th>IF Norm</th> <th>IF Max</th> </tr> </thead> <tbody> <tr> <td>White</td> <td>DC5V</td> <td>20mA</td> <td>20mA</td> <td>3.0V</td> <td>3.6V</td> </tr> <tr> <td>Red</td> <td>DC5V</td> <td>20mA</td> <td>20mA</td> <td>1.7V</td> <td>2.4V</td> </tr> <tr> <td>Yellow</td> <td>DC5V</td> <td>20mA</td> <td>20mA</td> <td>1.9V</td> <td>2.4V</td> </tr> <tr> <td>Blue</td> <td>DC5V</td> <td>20mA</td> <td>20mA</td> <td>3.0V</td> <td>3.6V</td> </tr> <tr> <td>Green</td> <td>DC5V</td> <td>20mA</td> <td>20mA</td> <td>1.9V</td> <td>2.4V</td> </tr> </tbody> </table>	Color	VR	IF	Recommended Operating	IF Norm	IF Max	White	DC5V	20mA	20mA	3.0V	3.6V	Red	DC5V	20mA	20mA	1.7V	2.4V	Yellow	DC5V	20mA	20mA	1.9V	2.4V	Blue	DC5V	20mA	20mA	3.0V	3.6V	Green	DC5V	20mA	20mA	1.9V	2.4V	
Color	VR	IF	Recommended Operating	IF Norm	IF Max																																	
White	DC5V	20mA	20mA	3.0V	3.6V																																	
Red	DC5V	20mA	20mA	1.7V	2.4V																																	
Yellow	DC5V	20mA	20mA	1.9V	2.4V																																	
Blue	DC5V	20mA	20mA	3.0V	3.6V																																	
Green	DC5V	20mA	20mA	1.9V	2.4V																																	
2	<p>● LS606</p> <table border="1"> <thead> <tr> <th>Color</th> <th>VR</th> <th>IF</th> <th>Recommended Operating</th> <th>IF Norm</th> <th>IF Max</th> </tr> </thead> <tbody> <tr> <td>White</td> <td>DC5V</td> <td>20mA</td> <td>20mA</td> <td>3.0V</td> <td>3.6V</td> </tr> <tr> <td>Red</td> <td>DC5V</td> <td>20mA</td> <td>20mA</td> <td>1.7V</td> <td>2.4V</td> </tr> <tr> <td>Yellow</td> <td>DC5V</td> <td>20mA</td> <td>20mA</td> <td>1.9V</td> <td>2.4V</td> </tr> <tr> <td>Blue</td> <td>DC5V</td> <td>20mA</td> <td>20mA</td> <td>3.0V</td> <td>3.6V</td> </tr> <tr> <td>Green</td> <td>DC5V</td> <td>20mA</td> <td>20mA</td> <td>1.9V</td> <td>2.4V</td> </tr> </tbody> </table>	Color	VR	IF	Recommended Operating	IF Norm	IF Max	White	DC5V	20mA	20mA	3.0V	3.6V	Red	DC5V	20mA	20mA	1.7V	2.4V	Yellow	DC5V	20mA	20mA	1.9V	2.4V	Blue	DC5V	20mA	20mA	3.0V	3.6V	Green	DC5V	20mA	20mA	1.9V	2.4V	
Color	VR	IF	Recommended Operating	IF Norm	IF Max																																	
White	DC5V	20mA	20mA	3.0V	3.6V																																	
Red	DC5V	20mA	20mA	1.7V	2.4V																																	
Yellow	DC5V	20mA	20mA	1.9V	2.4V																																	
Blue	DC5V	20mA	20mA	3.0V	3.6V																																	
Green	DC5V	20mA	20mA	1.9V	2.4V																																	

LAMP SERIES

6x6 Led Built-in Type

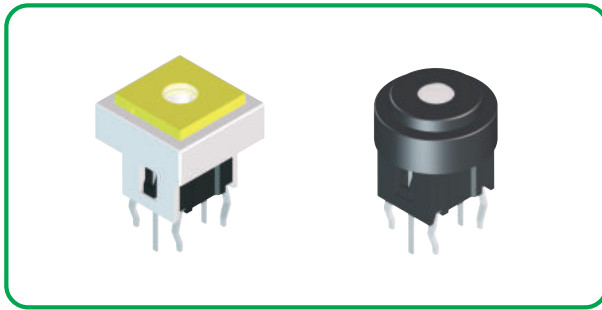

HOW TO ORDER

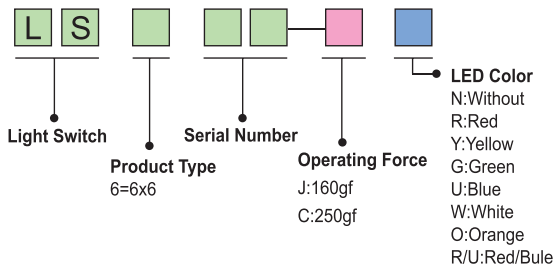

Specification

Items		Standard
Operating temperature range		-25°C to +85°C
Electrical performance	Rating	50mA, 30V DC
	Insulation resistance	100MΩ min. 250V DC
	Dielectric strength	AC250V(50-60Hz) for 1 min.
	Contact resistance	100mΩ max.
Durability	Lifetime	100,000 Cycles Min
Mechanical performance	Operating force	J:160gf C:250gf
	Travel	0.25 ± 0.1mm

Diagram

No.	Dimensions	Circuit Diagram																																				
		Pad Layout																																				
1	<p>● LS609</p> <table border="1"> <thead> <tr> <th>Color</th> <th>VR</th> <th>IF</th> <th>Recommended Operating</th> <th>IF Norml</th> <th>IF Max</th> </tr> </thead> <tbody> <tr> <td>White</td> <td>DC5V</td> <td>20mA</td> <td>20mA</td> <td>3.0V</td> <td>3.6V</td> </tr> <tr> <td>Red</td> <td>DC5V</td> <td>20mA</td> <td>20mA</td> <td>1.7V</td> <td>2.4V</td> </tr> <tr> <td>Yellow</td> <td>DC5V</td> <td>20mA</td> <td>20mA</td> <td>1.9V</td> <td>2.4V</td> </tr> <tr> <td>Blue</td> <td>DC5V</td> <td>20mA</td> <td>20mA</td> <td>3.0V</td> <td>3.6V</td> </tr> <tr> <td>Green</td> <td>DC5V</td> <td>20mA</td> <td>20mA</td> <td>1.9V</td> <td>2.4V</td> </tr> </tbody> </table>	Color	VR	IF	Recommended Operating	IF Norml	IF Max	White	DC5V	20mA	20mA	3.0V	3.6V	Red	DC5V	20mA	20mA	1.7V	2.4V	Yellow	DC5V	20mA	20mA	1.9V	2.4V	Blue	DC5V	20mA	20mA	3.0V	3.6V	Green	DC5V	20mA	20mA	1.9V	2.4V	
Color	VR	IF	Recommended Operating	IF Norml	IF Max																																	
White	DC5V	20mA	20mA	3.0V	3.6V																																	
Red	DC5V	20mA	20mA	1.7V	2.4V																																	
Yellow	DC5V	20mA	20mA	1.9V	2.4V																																	
Blue	DC5V	20mA	20mA	3.0V	3.6V																																	
Green	DC5V	20mA	20mA	1.9V	2.4V																																	
2	<p>● LS610</p> <table border="1"> <thead> <tr> <th>Color</th> <th>VR</th> <th>IF</th> <th>Recommended Operating</th> <th>IF Norml</th> <th>IF Max</th> </tr> </thead> <tbody> <tr> <td>White</td> <td>DC5V</td> <td>20mA</td> <td>20mA</td> <td>3.0V</td> <td>3.6V</td> </tr> <tr> <td>Red</td> <td>DC5V</td> <td>20mA</td> <td>20mA</td> <td>1.7V</td> <td>2.4V</td> </tr> <tr> <td>Yellow</td> <td>DC5V</td> <td>20mA</td> <td>20mA</td> <td>1.9V</td> <td>2.4V</td> </tr> <tr> <td>Blue</td> <td>DC5V</td> <td>20mA</td> <td>20mA</td> <td>3.0V</td> <td>3.6V</td> </tr> <tr> <td>Green</td> <td>DC5V</td> <td>20mA</td> <td>20mA</td> <td>1.9V</td> <td>2.4V</td> </tr> </tbody> </table>	Color	VR	IF	Recommended Operating	IF Norml	IF Max	White	DC5V	20mA	20mA	3.0V	3.6V	Red	DC5V	20mA	20mA	1.7V	2.4V	Yellow	DC5V	20mA	20mA	1.9V	2.4V	Blue	DC5V	20mA	20mA	3.0V	3.6V	Green	DC5V	20mA	20mA	1.9V	2.4V	
Color	VR	IF	Recommended Operating	IF Norml	IF Max																																	
White	DC5V	20mA	20mA	3.0V	3.6V																																	
Red	DC5V	20mA	20mA	1.7V	2.4V																																	
Yellow	DC5V	20mA	20mA	1.9V	2.4V																																	
Blue	DC5V	20mA	20mA	3.0V	3.6V																																	
Green	DC5V	20mA	20mA	1.9V	2.4V																																	

LAMP SERIES

6.0x6.0 Led Built-in Type



HOW TO ORDER

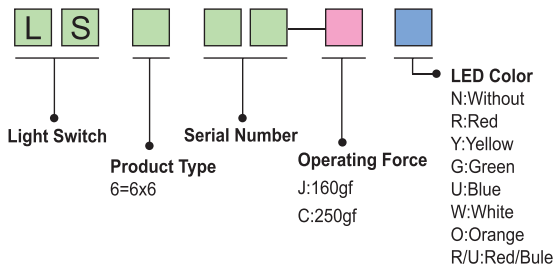

LIGHT SWITCH

Specification

Items		Standard
Operating temperature range		-25°C to +85°C
Electrical performance	Rating	100mA. 30V DC
	Insulation resistance	100MΩ min. 100V DC
	Dielectric strength	250V AC for 1 min.
	Contact resistance	100mΩ max.
Durability	Lifetime	100,000 Cycles Min
Mechanical performance	Operating force	J:160gf C:250gf
	Travel	0.25 ± 0.1mm

Diagram

No.	Dimensions	Circuit Diagram Pad Layout
1	<p>● LS611</p>	

LAMP SERIES

6.0x6.0 Led Built-in Type

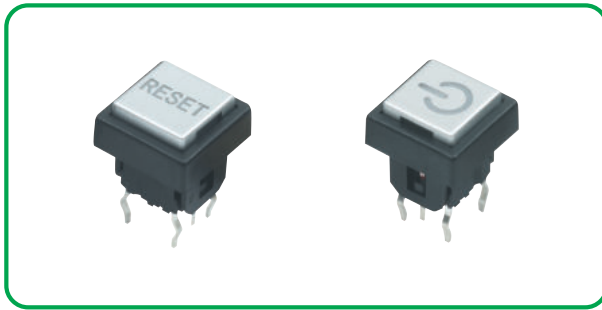

HOW TO ORDER

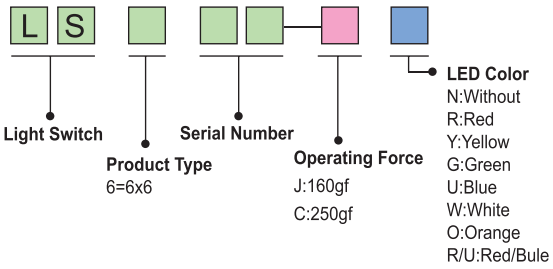

Specification

Items		Standard
Operating temperature range		-25°C to +85°C
Electrical performance	Rating	100mA, 30V DC
	Insulation resistance	100MΩ min. 100V DC
	Dielectric strength	250V AC for 1 min.
	Contact resistance	100mΩ max.
Durability	Lifetime	100,000 Cycles Min
Mechanical performance	Operating force	J:160gf C:250gf
	Travel	0.25 ± 0.1mm

Diagram

No.	Dimensions	Circuit Diagram
		Pad Layout
1	<p>● LS613</p>	
2	<p>● LS614</p>	

LAMP SERIES

6x6 Led Built-in Type

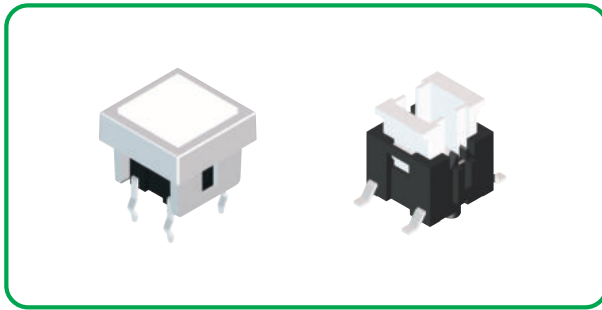

HOW TO ORDER

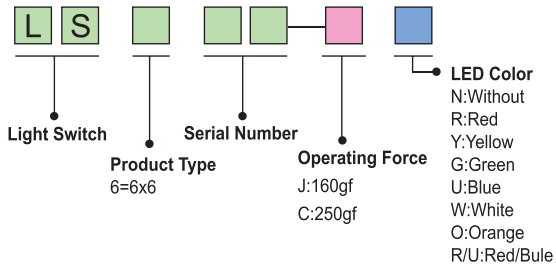

Specification

Items		Standard
Operating temperature range		-25°C to +85°C
Electrical performance	Rating	50mA, 30V DC
	Insulation resistance	100MΩ min. 250V DC
	Dielectric strength	AC250V(50-60Hz) for 1 min.
	Contact resistance	100mΩ max.
Durability	Lifetime	100,000 Cycles Min
Mechanical performance	Operating force	J:160gf C:250gf
	Travel	0.25 ± 0.1mm

Diagram

No.	Dimensions	Circuit Diagram																																				
		Pad Layout																																				
1	<p>● LS615</p>	<p>Circuit Diagram</p> <p>PCB Layout Recommended</p>																																				
2	<p>● LS616</p> <table border="1"> <thead> <tr> <th>Color</th> <th>VR</th> <th>IF</th> <th>Recommended Operating</th> <th>IF Nom</th> <th>IF Max</th> </tr> </thead> <tbody> <tr> <td>White</td> <td>DC5V</td> <td>20mA</td> <td>20mA</td> <td>3.0V</td> <td>3.6V</td> </tr> <tr> <td>Red</td> <td>DC5V</td> <td>20mA</td> <td>20mA</td> <td>1.7V</td> <td>2.4V</td> </tr> <tr> <td>Yellow</td> <td>DC5V</td> <td>20mA</td> <td>20mA</td> <td>1.9V</td> <td>2.4V</td> </tr> <tr> <td>Blue</td> <td>DC5V</td> <td>20mA</td> <td>20mA</td> <td>3.0V</td> <td>3.6V</td> </tr> <tr> <td>Green</td> <td>DC5V</td> <td>20mA</td> <td>20mA</td> <td>1.9V</td> <td>2.4V</td> </tr> </tbody> </table>	Color	VR	IF	Recommended Operating	IF Nom	IF Max	White	DC5V	20mA	20mA	3.0V	3.6V	Red	DC5V	20mA	20mA	1.7V	2.4V	Yellow	DC5V	20mA	20mA	1.9V	2.4V	Blue	DC5V	20mA	20mA	3.0V	3.6V	Green	DC5V	20mA	20mA	1.9V	2.4V	<p>Circuit Diagram</p> <p>PCB Layout Recommended</p>
Color	VR	IF	Recommended Operating	IF Nom	IF Max																																	
White	DC5V	20mA	20mA	3.0V	3.6V																																	
Red	DC5V	20mA	20mA	1.7V	2.4V																																	
Yellow	DC5V	20mA	20mA	1.9V	2.4V																																	
Blue	DC5V	20mA	20mA	3.0V	3.6V																																	
Green	DC5V	20mA	20mA	1.9V	2.4V																																	

LAMP SERIES

6x6 Led Built-in Type

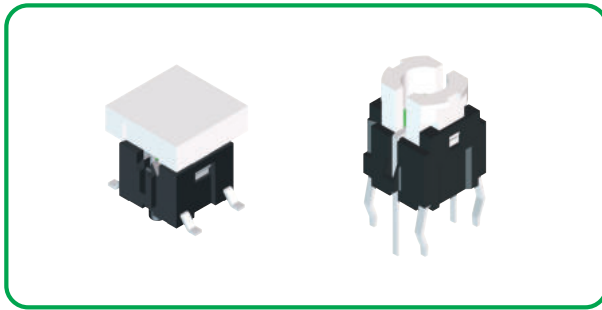

HOW TO ORDER

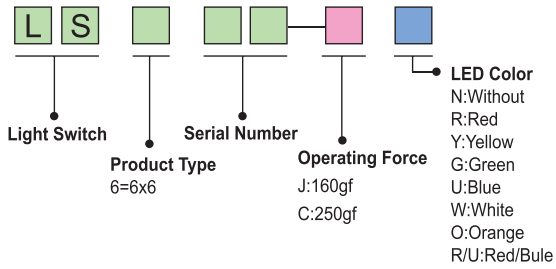

Specification

Items		Standard
Operating temperature range		-25°C to +85°C
Electrical performance	Rating	50mA, 30V DC
	Insulation resistance	100MΩ min. 250V DC
	Dielectric strength	AC250V(50-60Hz) for 1 min.
	Contact resistance	100mΩ max.
Durability	Lifetime	100,000 Cycles Min
Mechanical performance	Operating force	J:160gf C:250gf
	Travel	0.25 ± 0.1mm

LIGHT SWITCH

Diagram

No.	Dimensions	Circuit Diagram																																				
		Pad Layout																																				
1	<p>● LS617</p>																																					
2	<p>● LS618</p> <table border="1"> <thead> <tr> <th>Color</th> <th>VR</th> <th>IF</th> <th>Recommended Operating</th> <th>IF Noml</th> <th>IF Max</th> </tr> </thead> <tbody> <tr> <td>White</td> <td>DC5V</td> <td>20mA</td> <td>20mA</td> <td>3.0V</td> <td>3.6V</td> </tr> <tr> <td>Red</td> <td>DC5V</td> <td>20mA</td> <td>20mA</td> <td>1.7V</td> <td>2.4V</td> </tr> <tr> <td>Yellow</td> <td>DC5V</td> <td>20mA</td> <td>20mA</td> <td>1.9V</td> <td>2.4V</td> </tr> <tr> <td>Blue</td> <td>DC5V</td> <td>20mA</td> <td>20mA</td> <td>3.0V</td> <td>3.6V</td> </tr> <tr> <td>Green</td> <td>DC5V</td> <td>20mA</td> <td>20mA</td> <td>1.9V</td> <td>2.4V</td> </tr> </tbody> </table>	Color	VR	IF	Recommended Operating	IF Noml	IF Max	White	DC5V	20mA	20mA	3.0V	3.6V	Red	DC5V	20mA	20mA	1.7V	2.4V	Yellow	DC5V	20mA	20mA	1.9V	2.4V	Blue	DC5V	20mA	20mA	3.0V	3.6V	Green	DC5V	20mA	20mA	1.9V	2.4V	
Color	VR	IF	Recommended Operating	IF Noml	IF Max																																	
White	DC5V	20mA	20mA	3.0V	3.6V																																	
Red	DC5V	20mA	20mA	1.7V	2.4V																																	
Yellow	DC5V	20mA	20mA	1.9V	2.4V																																	
Blue	DC5V	20mA	20mA	3.0V	3.6V																																	
Green	DC5V	20mA	20mA	1.9V	2.4V																																	

LAMP SERIES

6x6 Led Built-in Type

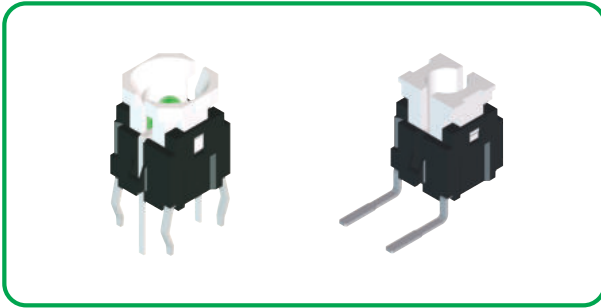

HOW TO ORDER

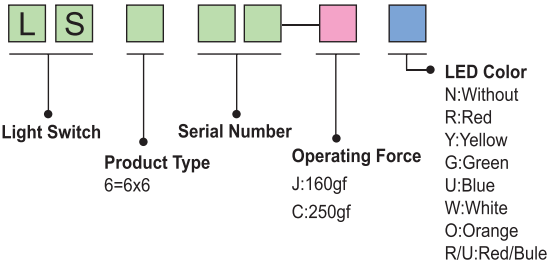

Specification

Items		Standard
Operating temperature range		-25°C to +85°C
Electrical performance	Rating	50mA, 30V DC
	Insulation resistance	100MΩ min. 250V DC
	Dielectric strength	AC250V(50-60Hz) for 1 min.
	Contact resistance	100mΩ max.
Durability	Lifetime	100,000 Cycles Min
Mechanical performance	Operating force	J:160gf C:250gf
	Travel	0.25 ± 0.1mm

Diagram

No.	Dimensions	Circuit Diagram																														
		Pad Layout																														
1	<p>● LS619</p> <table border="1"> <thead> <tr> <th>Color</th> <th>VR</th> <th>IF</th> <th>Recommended Operating</th> <th>IF</th> </tr> </thead> <tbody> <tr> <td>White</td> <td>DC5V</td> <td>20mA</td> <td>20mA</td> <td>3.0V/3.6V</td> </tr> <tr> <td>Red</td> <td>DC5V</td> <td>20mA</td> <td>20mA</td> <td>1.7V/2.4V</td> </tr> <tr> <td>Yellow</td> <td>DC5V</td> <td>20mA</td> <td>20mA</td> <td>1.9V/2.4V</td> </tr> <tr> <td>Blue</td> <td>DC5V</td> <td>20mA</td> <td>20mA</td> <td>3.0V/3.6V</td> </tr> <tr> <td>Green</td> <td>DC5V</td> <td>20mA</td> <td>20mA</td> <td>1.9V/2.4V</td> </tr> </tbody> </table>	Color	VR	IF	Recommended Operating	IF	White	DC5V	20mA	20mA	3.0V/3.6V	Red	DC5V	20mA	20mA	1.7V/2.4V	Yellow	DC5V	20mA	20mA	1.9V/2.4V	Blue	DC5V	20mA	20mA	3.0V/3.6V	Green	DC5V	20mA	20mA	1.9V/2.4V	<p>Circuit Diagram</p> <p>PCB Layout Recommended</p>
Color	VR	IF	Recommended Operating	IF																												
White	DC5V	20mA	20mA	3.0V/3.6V																												
Red	DC5V	20mA	20mA	1.7V/2.4V																												
Yellow	DC5V	20mA	20mA	1.9V/2.4V																												
Blue	DC5V	20mA	20mA	3.0V/3.6V																												
Green	DC5V	20mA	20mA	1.9V/2.4V																												
2	<p>● LS620</p>	<p>Circuit Diagram</p>																														

LAMP SERIES

6x6 Led Built-in Type

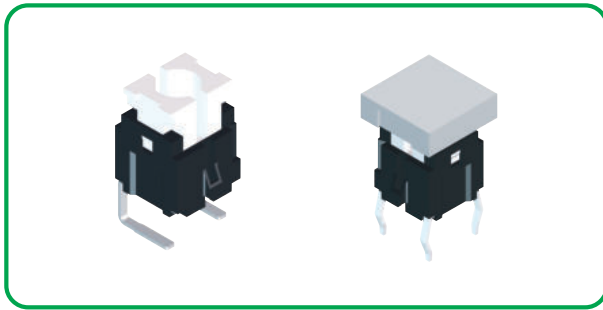

HOW TO ORDER

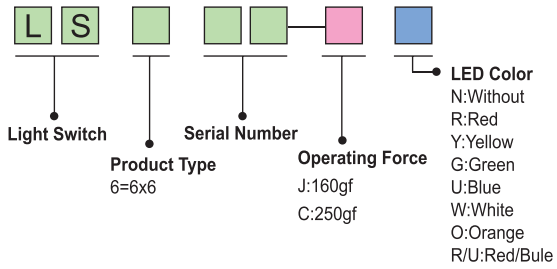

Specification

Items		Standard
Operating temperature range		-25°C to +85°C
Electrical performance	Rating	50mA, 30V DC
	Insulation resistance	100MΩ min. 250V DC
	Dielectric strength	AC250V(50-60Hz) for 1 min.
	Contact resistance	100mΩ max.
Durability	Lifetime	100,000 Cycles Min
Mechanical performance	Operating force	J:160gf C:250gf
	Travel	0.25 ± 0.1mm

Diagram

No.	Dimensions	Circuit Diagram
		Pad Layout
1	<p>● LS621</p>	<p>Circuit Diagram</p>
2	<p>● LS622</p>	<p>Circuit Diagram</p> <p>PCB Layout Recommended</p>

LAMP SERIES

6x6 Led Built-in Type

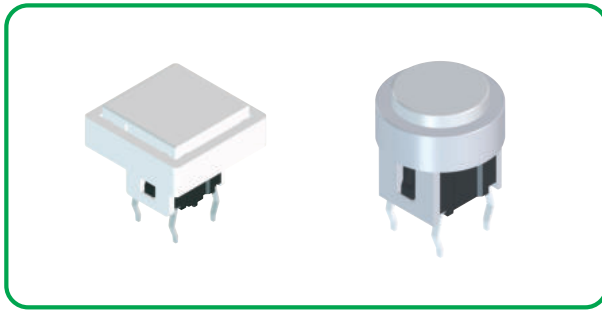

HOW TO ORDER

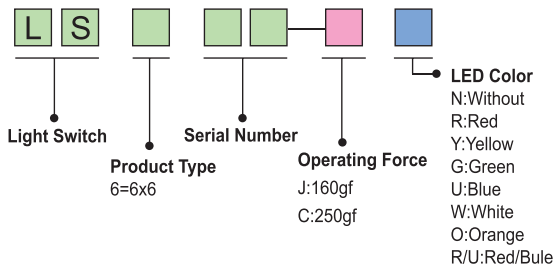

Specification

Items		Standard
Operating temperature range		-25°C to +85°C
Electrical performance	Rating	50mA, 30V DC
	Insulation resistance	100MΩ min. 250V DC
	Dielectric strength	AC250V(50-60Hz) for 1 min.
	Contact resistance	100mΩ max.
Durability	Lifetime	100,000 Cycles Min
Mechanical performance	Operating force	J:160gf C:250gf
	Travel	0.25 ± 0.1mm

Diagram

No.	Dimensions	Circuit Diagram
		Pad Layout
1	<p>● LS623</p>	
2	<p>● LS624</p>	

LIGHT SWITCH

LAMP SERIES

6x6 Led Built-in Type

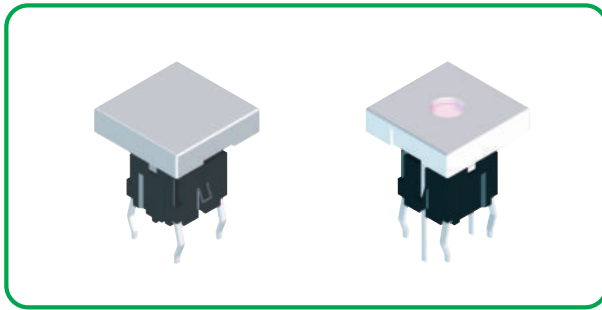

HOW TO ORDER

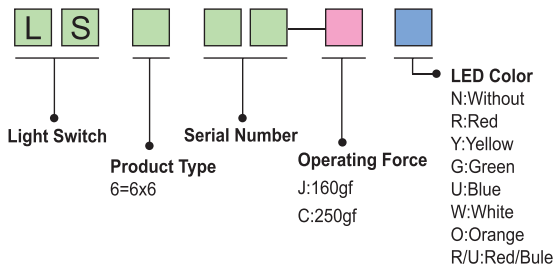

Specification

Items		Standard
Operating temperature range		-25°C to +85°C
Electrical performance	Rating	50mA, 30V DC
	Insulation resistance	100MΩ min. 250V DC
	Dielectric strength	AC250V(50-60Hz) for 1 min.
	Contact resistance	100mΩ max.
Durability	Lifetime	100,000 Cycles Min
Mechanical performance	Operating force	J:160gf C:250gf
	Travel	0.25 ± 0.1mm

LIGHT SWITCH

Diagram

No.	Dimensions	Circuit Diagram																																				
		Pad Layout																																				
1	<p>● LS625</p>	<p>Circuit Diagram</p> <p>PCB Layout Recommended</p>																																				
2	<p>● LS626</p> <table border="1"> <thead> <tr> <th>Color</th> <th>VR</th> <th>IF</th> <th>Recommended Operating</th> <th>IF Norm</th> <th>IF Max</th> </tr> </thead> <tbody> <tr> <td>White</td> <td>DC5V</td> <td>20mA</td> <td>20mA</td> <td>3.0V</td> <td>3.6V</td> </tr> <tr> <td>Red</td> <td>DC5V</td> <td>20mA</td> <td>20mA</td> <td>1.7V</td> <td>2.4V</td> </tr> <tr> <td>Yellow</td> <td>DC5V</td> <td>20mA</td> <td>20mA</td> <td>1.9V</td> <td>2.4V</td> </tr> <tr> <td>Blue</td> <td>DC5V</td> <td>20mA</td> <td>20mA</td> <td>3.0V</td> <td>3.6V</td> </tr> <tr> <td>Green</td> <td>DC5V</td> <td>20mA</td> <td>20mA</td> <td>1.9V</td> <td>2.4V</td> </tr> </tbody> </table>	Color	VR	IF	Recommended Operating	IF Norm	IF Max	White	DC5V	20mA	20mA	3.0V	3.6V	Red	DC5V	20mA	20mA	1.7V	2.4V	Yellow	DC5V	20mA	20mA	1.9V	2.4V	Blue	DC5V	20mA	20mA	3.0V	3.6V	Green	DC5V	20mA	20mA	1.9V	2.4V	<p>Circuit Diagram</p> <p>PCB Layout Recommended</p>
Color	VR	IF	Recommended Operating	IF Norm	IF Max																																	
White	DC5V	20mA	20mA	3.0V	3.6V																																	
Red	DC5V	20mA	20mA	1.7V	2.4V																																	
Yellow	DC5V	20mA	20mA	1.9V	2.4V																																	
Blue	DC5V	20mA	20mA	3.0V	3.6V																																	
Green	DC5V	20mA	20mA	1.9V	2.4V																																	

LAMP SERIES

6x6 Led Built-in Type

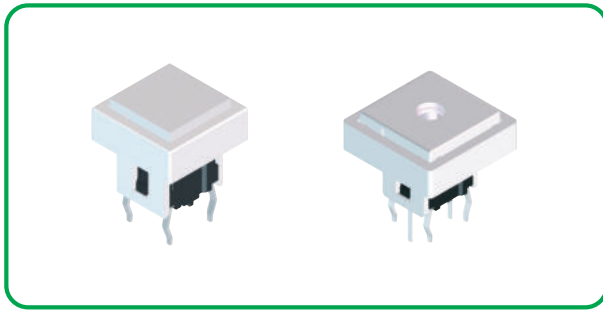

HOW TO ORDER

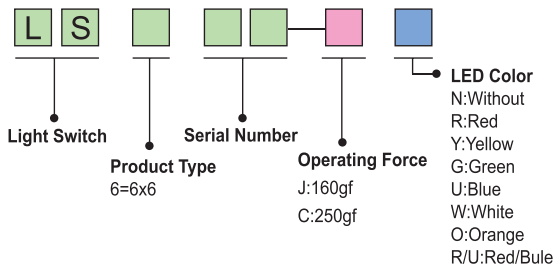

Specification

Items		Standard
Operating temperature range		-25°C to +85°C
Electrical performance	Rating	50mA, 30V DC
	Insulation resistance	100MΩ min. 250V DC
	Dielectric strength	AC250V(50-60Hz) for 1 min.
	Contact resistance	100mΩ max.
Durability	Lifetime	100,000 Cycles Min
Mechanical performance	Operating force	J:160gf C:250gf
	Travel	0.25 ± 0.1mm

Diagram

No.	Dimensions	Circuit Diagram
		Pad Layout
1		
2		

Color	VR	IF	Recommended Operating	IF Norm	IF Max
White	DC5V	20mA	20mA	3.0V	3.6V
Red	DC5V	20mA	20mA	1.7V	2.4V
Yellow	DC5V	20mA	20mA	1.9V	2.4V
Blue	DC5V	20mA	20mA	3.0V	3.6V
Green	DC5V	20mA	20mA	1.9V	2.4V

LIGHT SWITCH

LAMP SERIES

6x6 Led Built-in Type

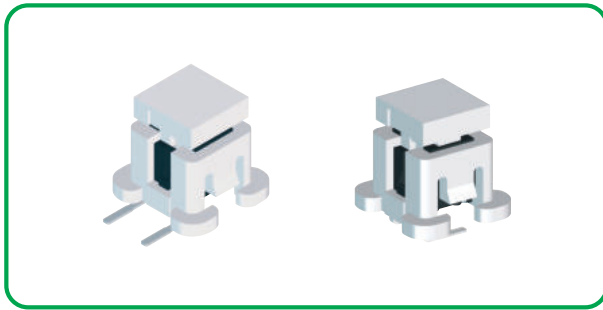

HOW TO ORDER

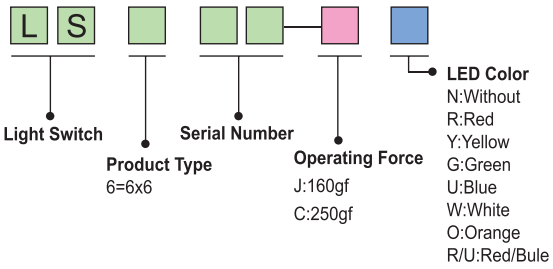

Specification

Items		Standard
Operating temperature range		-25°C to +85°C
Electrical performance	Rating	50mA, 30V DC
	Insulation resistance	100MΩ min. 250V DC
	Dielectric strength	AC250V(50-60Hz) for 1 min.
	Contact resistance	100mΩ max.
Durability	Lifetime	100,000 Cycles Min
Mechanical performance	Operating force	J:160gf C:250gf
	Travel	0.25 ± 0.1mm

Diagram

No.	Dimensions	Circuit Diagram
		Pad Layout
1	<p>● LS629</p>	<p>Circuit Diagram</p>
2	<p>● LS630</p>	<p>Circuit Diagram</p>

LIGHT SWITCH

LAMP SERIES

6x6 Led Built-in Type

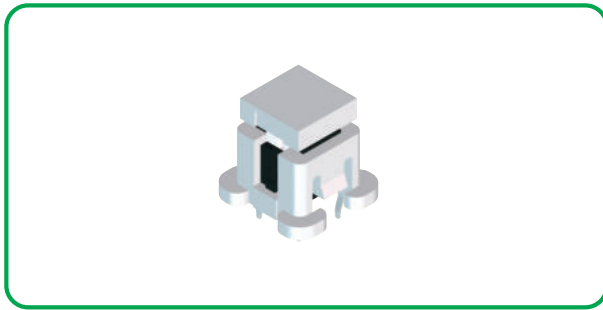

HOW TO ORDER

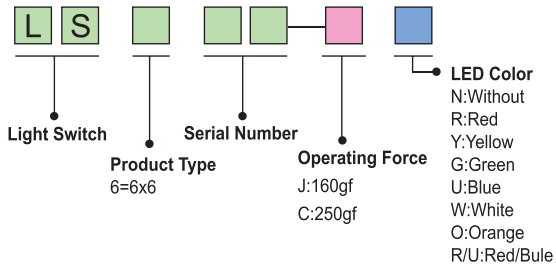

LIGHT SWITCH

Specification

Items		Standard
Operating temperature range		-25°C to +85°C
Electrical performance	Rating	50mA, 30V DC
	Insulation resistance	100MΩ min. 250V DC
	Dielectric strength	AC250V(50-60Hz) for 1 min.
	Contact resistance	100mΩ max.
Durability	Lifetime	100,000 Cycles Min
Mechanical performance	Operating force	J:160gf C:250gf
	Travel	0.25 ± 0.1mm

Diagram

No.	Dimensions	Circuit Diagram
		Pad Layout
1	<p>● LS631</p>	<p>Circuit Diagram</p> <p>PCB Layout Recommended</p>

LAMP SERIES

8.5x8.5 Led Built-in Type

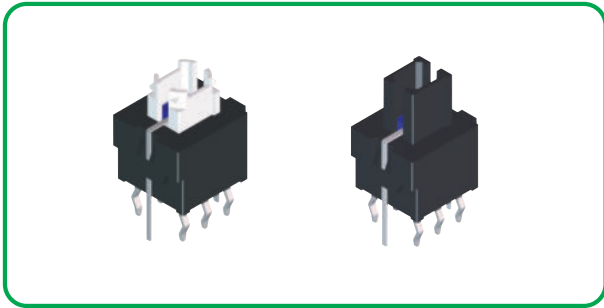

HOW TO ORDER

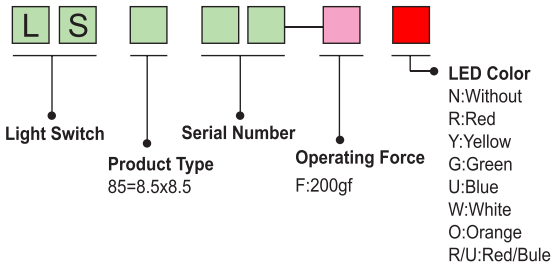

Specification

Items		Standard
Operating temperature range		-25°C to +85°C
Electrical performance	Rating	50mA. 30V DC
	Insulation resistance	100MΩ min. 250V DC
	Dielectric strength	AC250V(50-60Hz) for 1 min.
	Contact resistance	500mΩ max.
Durability	Lifetime	100,000 Cycles Min
Mechanical performance	Operating force	200 ± 50gf
	Travel	0.25 ± 0.1mm

Diagram

No.	Dimensions	Circuit Diagram Pad Layout																																				
1	<p>● LS8501</p> <table border="1"> <thead> <tr> <th>Color</th> <th>VR</th> <th>IF</th> <th>Recommended Operating</th> <th>IF Nom</th> <th>IF Max</th> </tr> </thead> <tbody> <tr> <td>White</td> <td>DC5V</td> <td>20mA</td> <td>20mA</td> <td>3.0V</td> <td>3.6V</td> </tr> <tr> <td>Red</td> <td>DC5V</td> <td>20mA</td> <td>20mA</td> <td>1.7V</td> <td>2.4V</td> </tr> <tr> <td>Yellow</td> <td>DC5V</td> <td>20mA</td> <td>20mA</td> <td>1.9V</td> <td>2.4V</td> </tr> <tr> <td>Blue</td> <td>DC5V</td> <td>20mA</td> <td>20mA</td> <td>3.0V</td> <td>3.6V</td> </tr> <tr> <td>Green</td> <td>DC5V</td> <td>20mA</td> <td>20mA</td> <td>1.9V</td> <td>2.4V</td> </tr> </tbody> </table> <p>Push No Sound No Lock Push No Lock Push To Lock Operating Type</p>	Color	VR	IF	Recommended Operating	IF Nom	IF Max	White	DC5V	20mA	20mA	3.0V	3.6V	Red	DC5V	20mA	20mA	1.7V	2.4V	Yellow	DC5V	20mA	20mA	1.9V	2.4V	Blue	DC5V	20mA	20mA	3.0V	3.6V	Green	DC5V	20mA	20mA	1.9V	2.4V	<p>Circuit Diagram</p> <p>PCB Layout Recommended</p>
Color	VR	IF	Recommended Operating	IF Nom	IF Max																																	
White	DC5V	20mA	20mA	3.0V	3.6V																																	
Red	DC5V	20mA	20mA	1.7V	2.4V																																	
Yellow	DC5V	20mA	20mA	1.9V	2.4V																																	
Blue	DC5V	20mA	20mA	3.0V	3.6V																																	
Green	DC5V	20mA	20mA	1.9V	2.4V																																	
2	<p>● LS8502</p> <table border="1"> <thead> <tr> <th>Color</th> <th>VR</th> <th>IF</th> <th>Recommended Operating</th> <th>IF Nom</th> <th>IF Max</th> </tr> </thead> <tbody> <tr> <td>White</td> <td>DC5V</td> <td>20mA</td> <td>20mA</td> <td>3.0V</td> <td>3.6V</td> </tr> <tr> <td>Red</td> <td>DC5V</td> <td>20mA</td> <td>20mA</td> <td>1.7V</td> <td>2.4V</td> </tr> <tr> <td>Yellow</td> <td>DC5V</td> <td>20mA</td> <td>20mA</td> <td>1.9V</td> <td>2.4V</td> </tr> <tr> <td>Blue</td> <td>DC5V</td> <td>20mA</td> <td>20mA</td> <td>3.0V</td> <td>3.6V</td> </tr> <tr> <td>Green</td> <td>DC5V</td> <td>20mA</td> <td>20mA</td> <td>1.9V</td> <td>2.4V</td> </tr> </tbody> </table> <p>Push No Sound No Lock Push No Lock Push To Lock Operating Type</p>	Color	VR	IF	Recommended Operating	IF Nom	IF Max	White	DC5V	20mA	20mA	3.0V	3.6V	Red	DC5V	20mA	20mA	1.7V	2.4V	Yellow	DC5V	20mA	20mA	1.9V	2.4V	Blue	DC5V	20mA	20mA	3.0V	3.6V	Green	DC5V	20mA	20mA	1.9V	2.4V	<p>Circuit Diagram</p> <p>PCB Layout Recommended</p>
Color	VR	IF	Recommended Operating	IF Nom	IF Max																																	
White	DC5V	20mA	20mA	3.0V	3.6V																																	
Red	DC5V	20mA	20mA	1.7V	2.4V																																	
Yellow	DC5V	20mA	20mA	1.9V	2.4V																																	
Blue	DC5V	20mA	20mA	3.0V	3.6V																																	
Green	DC5V	20mA	20mA	1.9V	2.4V																																	

LAMP SERIES

8.5x8.5 Led Built-in Type

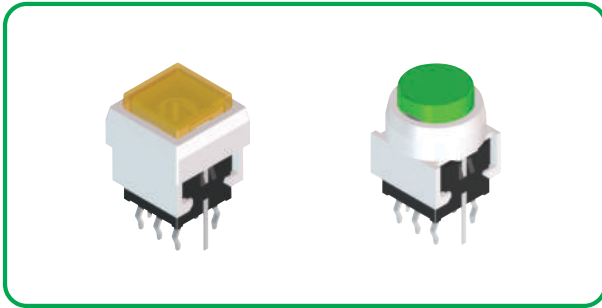

HOW TO ORDER

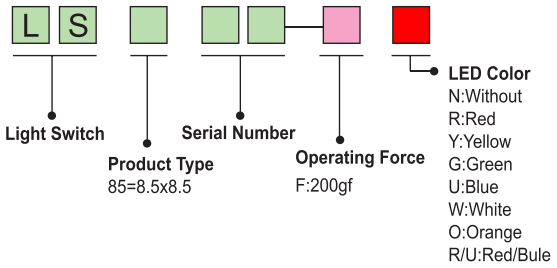

Specification

Items		Standard
Operating temperature range		-25°C to +85°C
Electrical performance	Rating	50mA. 30V DC
	Insulation resistance	100MΩ min. 250V DC
	Dielectric strength	AC250V(50-60Hz) for 1 min.
	Contact resistance	500mΩ max.
Durability	Lifetime	100,000 Cycles Min
Mechanical performance	Operating force	200 ± 50gf
	Travel	0.25 ± 0.1mm

Diagram

No.	Dimensions	Circuit Diagram Pad Layout																																				
1	<p>● LS8503</p> <table border="1"> <thead> <tr> <th>Color</th> <th>VR</th> <th>IF</th> <th>Recommended Operating</th> <th>IF Nom</th> <th>IF Max</th> </tr> </thead> <tbody> <tr> <td>White</td> <td>DC5V</td> <td>20mA</td> <td>20mA</td> <td>3.0V</td> <td>3.6V</td> </tr> <tr> <td>Red</td> <td>DC5V</td> <td>20mA</td> <td>20mA</td> <td>1.7V</td> <td>2.4V</td> </tr> <tr> <td>Yellow</td> <td>DC5V</td> <td>20mA</td> <td>20mA</td> <td>1.9V</td> <td>2.4V</td> </tr> <tr> <td>Blue</td> <td>DC5V</td> <td>20mA</td> <td>20mA</td> <td>3.0V</td> <td>3.6V</td> </tr> <tr> <td>Green</td> <td>DC5V</td> <td>20mA</td> <td>20mA</td> <td>1.9V</td> <td>2.4V</td> </tr> </tbody> </table> <p> Push No Sound No Lock Push No Lock Push To Lock Operating Type </p>	Color	VR	IF	Recommended Operating	IF Nom	IF Max	White	DC5V	20mA	20mA	3.0V	3.6V	Red	DC5V	20mA	20mA	1.7V	2.4V	Yellow	DC5V	20mA	20mA	1.9V	2.4V	Blue	DC5V	20mA	20mA	3.0V	3.6V	Green	DC5V	20mA	20mA	1.9V	2.4V	<p>Circuit Diagram</p> <p>PCB Layout Recommended</p>
Color	VR	IF	Recommended Operating	IF Nom	IF Max																																	
White	DC5V	20mA	20mA	3.0V	3.6V																																	
Red	DC5V	20mA	20mA	1.7V	2.4V																																	
Yellow	DC5V	20mA	20mA	1.9V	2.4V																																	
Blue	DC5V	20mA	20mA	3.0V	3.6V																																	
Green	DC5V	20mA	20mA	1.9V	2.4V																																	
2	<p>● LS8504</p> <table border="1"> <thead> <tr> <th>Color</th> <th>VR</th> <th>IF</th> <th>Recommended Operating</th> <th>IF Nom</th> <th>IF Max</th> </tr> </thead> <tbody> <tr> <td>White</td> <td>DC5V</td> <td>20mA</td> <td>20mA</td> <td>3.0V</td> <td>3.6V</td> </tr> <tr> <td>Red</td> <td>DC5V</td> <td>20mA</td> <td>20mA</td> <td>1.7V</td> <td>2.4V</td> </tr> <tr> <td>Yellow</td> <td>DC5V</td> <td>20mA</td> <td>20mA</td> <td>1.9V</td> <td>2.4V</td> </tr> <tr> <td>Blue</td> <td>DC5V</td> <td>20mA</td> <td>20mA</td> <td>3.0V</td> <td>3.6V</td> </tr> <tr> <td>Green</td> <td>DC5V</td> <td>20mA</td> <td>20mA</td> <td>1.9V</td> <td>2.4V</td> </tr> </tbody> </table> <p> Push No Sound No Lock Push No Lock Push To Lock Operating Type </p>	Color	VR	IF	Recommended Operating	IF Nom	IF Max	White	DC5V	20mA	20mA	3.0V	3.6V	Red	DC5V	20mA	20mA	1.7V	2.4V	Yellow	DC5V	20mA	20mA	1.9V	2.4V	Blue	DC5V	20mA	20mA	3.0V	3.6V	Green	DC5V	20mA	20mA	1.9V	2.4V	<p>Circuit Diagram</p> <p>PCB Layout Recommended</p>
Color	VR	IF	Recommended Operating	IF Nom	IF Max																																	
White	DC5V	20mA	20mA	3.0V	3.6V																																	
Red	DC5V	20mA	20mA	1.7V	2.4V																																	
Yellow	DC5V	20mA	20mA	1.9V	2.4V																																	
Blue	DC5V	20mA	20mA	3.0V	3.6V																																	
Green	DC5V	20mA	20mA	1.9V	2.4V																																	

LAMP SERIES

8.5x8.5 Led Built-in Type

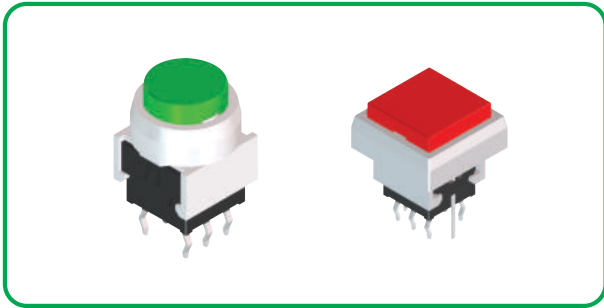

HOW TO ORDER

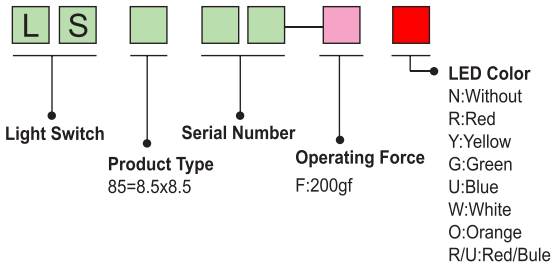

Specification

Items		Standard
Operating temperature range		-25℃ to +85℃
Electrical performance	Rating	50mA. 30V DC
	Insulation resistance	100MΩ min. 250V DC
	Dielectric strength	AC250V(50-60Hz) for 1 min.
	Contact resistance	500mΩ max.
Durability	Lifetime	100,000 Cycles Min
Mechanical performance	Operating force	200 ± 50gf
	Travel	0.25 ± 0.1mm

Diagram

No.	Dimensions	Circuit Diagram Pad Layout																																								
1	<p>● LS8505</p> <table border="1"> <tr><td>Push No Sound No Lock</td></tr> <tr><td>Push No Lock</td></tr> <tr><td>Push To Lock</td></tr> <tr><td>Operating Type</td></tr> </table>	Push No Sound No Lock	Push No Lock	Push To Lock	Operating Type																																					
Push No Sound No Lock																																										
Push No Lock																																										
Push To Lock																																										
Operating Type																																										
2	<p>● LS8506</p> <table border="1"> <tr><td>Push No Sound No Lock</td></tr> <tr><td>Push No Lock</td></tr> <tr><td>Push To Lock</td></tr> <tr><td>Operating Type</td></tr> </table> <table border="1"> <thead> <tr> <th>Color</th> <th>VR</th> <th>IF</th> <th>Recommended Operating</th> <th>IF Noml</th> <th>IF Max</th> </tr> </thead> <tbody> <tr><td>White</td><td>DC5V</td><td>20mA</td><td>20mA</td><td>3.0V</td><td>3.6V</td></tr> <tr><td>Red</td><td>DC5V</td><td>20mA</td><td>20mA</td><td>1.7V</td><td>2.4V</td></tr> <tr><td>Yellow</td><td>DC5V</td><td>20mA</td><td>20mA</td><td>1.9V</td><td>2.4V</td></tr> <tr><td>Blue</td><td>DC5V</td><td>20mA</td><td>20mA</td><td>3.0V</td><td>3.6V</td></tr> <tr><td>Green</td><td>DC5V</td><td>20mA</td><td>20mA</td><td>1.9V</td><td>2.4V</td></tr> </tbody> </table>	Push No Sound No Lock	Push No Lock	Push To Lock	Operating Type	Color	VR	IF	Recommended Operating	IF Noml	IF Max	White	DC5V	20mA	20mA	3.0V	3.6V	Red	DC5V	20mA	20mA	1.7V	2.4V	Yellow	DC5V	20mA	20mA	1.9V	2.4V	Blue	DC5V	20mA	20mA	3.0V	3.6V	Green	DC5V	20mA	20mA	1.9V	2.4V	
Push No Sound No Lock																																										
Push No Lock																																										
Push To Lock																																										
Operating Type																																										
Color	VR	IF	Recommended Operating	IF Noml	IF Max																																					
White	DC5V	20mA	20mA	3.0V	3.6V																																					
Red	DC5V	20mA	20mA	1.7V	2.4V																																					
Yellow	DC5V	20mA	20mA	1.9V	2.4V																																					
Blue	DC5V	20mA	20mA	3.0V	3.6V																																					
Green	DC5V	20mA	20mA	1.9V	2.4V																																					

LAMP SERIES

8.5x8.5 Led Built-in Type

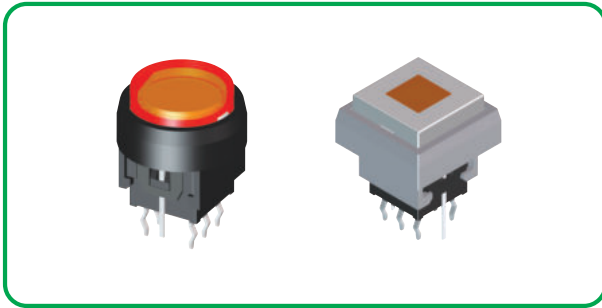

HOW TO ORDER

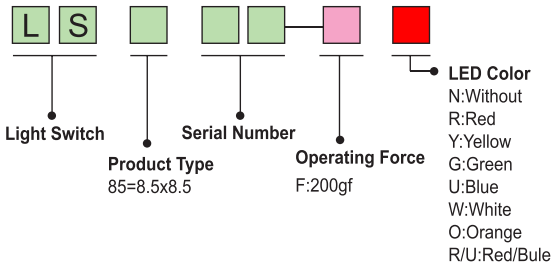

Specification

Items		Standard
Operating temperature range		-25°C to +85°C
Electrical performance	Rating	50mA, 30V DC
	Insulation resistance	100MΩ min. 250V DC
	Dielectric strength	AC250V(50-60Hz) for 1 min.
	Contact resistance	500mΩ max.
Durability	Lifetime	100,000 Cycles Min
Mechanical performance	Operating force	200 ± 50gf
	Travel	0.25 ± 0.1mm

Diagram

No.	Dimensions	Circuit Diagram Pad Layout																																		
1	<p>● LS8507</p> <table border="1"> <thead> <tr> <th>Color</th> <th>VR</th> <th>IF</th> <th>Recommended Operating</th> <th>IF Norm/Max</th> </tr> </thead> <tbody> <tr> <td>White</td> <td>DC5V</td> <td>20mA</td> <td>20mA</td> <td>3.0V/3.6V</td> </tr> <tr> <td>Red</td> <td>DC5V</td> <td>20mA</td> <td>20mA</td> <td>1.7V/2.4V</td> </tr> <tr> <td>Yellow</td> <td>DC5V</td> <td>20mA</td> <td>20mA</td> <td>1.9V/2.4V</td> </tr> <tr> <td>Blue</td> <td>DC5V</td> <td>20mA</td> <td>20mA</td> <td>3.0V/3.6V</td> </tr> <tr> <td>Green</td> <td>DC5V</td> <td>20mA</td> <td>20mA</td> <td>1.9V/2.4V</td> </tr> </tbody> </table> <table border="1"> <tbody> <tr> <td>Push No Sound No Lock</td> </tr> <tr> <td>Push No Lock</td> </tr> <tr> <td>Push To Lock</td> </tr> <tr> <td>Operating Type</td> </tr> </tbody> </table>	Color	VR	IF	Recommended Operating	IF Norm/Max	White	DC5V	20mA	20mA	3.0V/3.6V	Red	DC5V	20mA	20mA	1.7V/2.4V	Yellow	DC5V	20mA	20mA	1.9V/2.4V	Blue	DC5V	20mA	20mA	3.0V/3.6V	Green	DC5V	20mA	20mA	1.9V/2.4V	Push No Sound No Lock	Push No Lock	Push To Lock	Operating Type	<p>Circuit Diagram</p> <p>PCB Layout Recommended</p>
Color	VR	IF	Recommended Operating	IF Norm/Max																																
White	DC5V	20mA	20mA	3.0V/3.6V																																
Red	DC5V	20mA	20mA	1.7V/2.4V																																
Yellow	DC5V	20mA	20mA	1.9V/2.4V																																
Blue	DC5V	20mA	20mA	3.0V/3.6V																																
Green	DC5V	20mA	20mA	1.9V/2.4V																																
Push No Sound No Lock																																				
Push No Lock																																				
Push To Lock																																				
Operating Type																																				
2	<p>● LS8508</p> <table border="1"> <thead> <tr> <th>Color</th> <th>VR</th> <th>IF</th> <th>Recommended Operating</th> <th>IF Norm/Max</th> </tr> </thead> <tbody> <tr> <td>White</td> <td>DC5V</td> <td>20mA</td> <td>20mA</td> <td>3.0V/3.6V</td> </tr> <tr> <td>Red</td> <td>DC5V</td> <td>20mA</td> <td>20mA</td> <td>1.7V/2.4V</td> </tr> <tr> <td>Yellow</td> <td>DC5V</td> <td>20mA</td> <td>20mA</td> <td>1.9V/2.4V</td> </tr> <tr> <td>Blue</td> <td>DC5V</td> <td>20mA</td> <td>20mA</td> <td>3.0V/3.6V</td> </tr> <tr> <td>Green</td> <td>DC5V</td> <td>20mA</td> <td>20mA</td> <td>1.9V/2.4V</td> </tr> </tbody> </table> <table border="1"> <tbody> <tr> <td>Push No Sound No Lock</td> </tr> <tr> <td>Push No Lock</td> </tr> <tr> <td>Push To Lock</td> </tr> <tr> <td>Operating Type</td> </tr> </tbody> </table>	Color	VR	IF	Recommended Operating	IF Norm/Max	White	DC5V	20mA	20mA	3.0V/3.6V	Red	DC5V	20mA	20mA	1.7V/2.4V	Yellow	DC5V	20mA	20mA	1.9V/2.4V	Blue	DC5V	20mA	20mA	3.0V/3.6V	Green	DC5V	20mA	20mA	1.9V/2.4V	Push No Sound No Lock	Push No Lock	Push To Lock	Operating Type	<p>Circuit Diagram</p> <p>PCB Layout Recommended</p>
Color	VR	IF	Recommended Operating	IF Norm/Max																																
White	DC5V	20mA	20mA	3.0V/3.6V																																
Red	DC5V	20mA	20mA	1.7V/2.4V																																
Yellow	DC5V	20mA	20mA	1.9V/2.4V																																
Blue	DC5V	20mA	20mA	3.0V/3.6V																																
Green	DC5V	20mA	20mA	1.9V/2.4V																																
Push No Sound No Lock																																				
Push No Lock																																				
Push To Lock																																				
Operating Type																																				

LAMP SERIES

8.5x8.5 Led Built-in Type

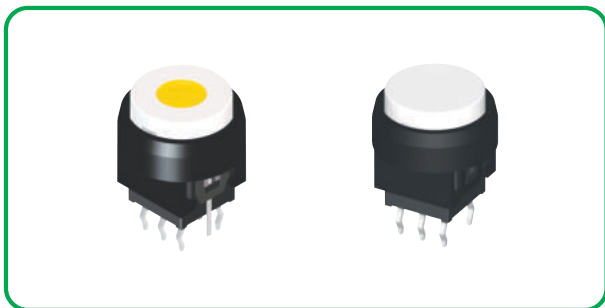

HOW TO ORDER

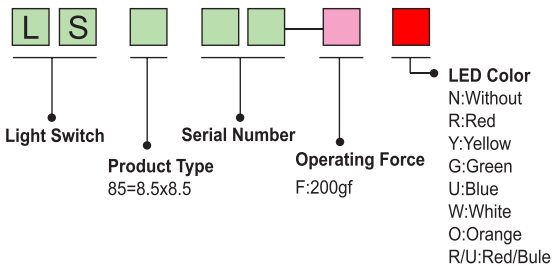

Specification

Items		Standard
Operating temperature range		-25°C to +85°C
Electrical performance	Rating	50mA. 30V DC
	Insulation resistance	100MΩ min. 250V DC
	Dielectric strength	AC250V(50-60Hz) for 1 min.
	Contact resistance	500mΩ max.
Durability	Lifetime	100,000 Cycles Min
Mechanical performance	Operating force	200 ± 50gf
	Travel	0.25 ± 0.1mm

Diagram

No.	Dimensions	Circuit Diagram Pad Layout																																				
1	<p>● LS8509</p> <table border="1"> <thead> <tr> <th>Color</th> <th>VR</th> <th>IF</th> <th>Recommended Operating</th> <th>IF Noml</th> <th>IF Max</th> </tr> </thead> <tbody> <tr> <td>White</td> <td>DC5V</td> <td>20mA</td> <td>20mA</td> <td>3.0V</td> <td>3.6V</td> </tr> <tr> <td>Red</td> <td>DC5V</td> <td>20mA</td> <td>20mA</td> <td>1.7V</td> <td>2.4V</td> </tr> <tr> <td>Yellow</td> <td>DC5V</td> <td>20mA</td> <td>20mA</td> <td>1.9V</td> <td>2.4V</td> </tr> <tr> <td>Blue</td> <td>DC5V</td> <td>20mA</td> <td>20mA</td> <td>3.0V</td> <td>3.6V</td> </tr> <tr> <td>Green</td> <td>DC5V</td> <td>20mA</td> <td>20mA</td> <td>1.9V</td> <td>2.4V</td> </tr> </tbody> </table> <p>Push No Sound No Lock Push No Lock Push To Lock Operating Type</p>	Color	VR	IF	Recommended Operating	IF Noml	IF Max	White	DC5V	20mA	20mA	3.0V	3.6V	Red	DC5V	20mA	20mA	1.7V	2.4V	Yellow	DC5V	20mA	20mA	1.9V	2.4V	Blue	DC5V	20mA	20mA	3.0V	3.6V	Green	DC5V	20mA	20mA	1.9V	2.4V	<p>Circuit Diagram</p> <p>PCB Layout Recommended</p>
Color	VR	IF	Recommended Operating	IF Noml	IF Max																																	
White	DC5V	20mA	20mA	3.0V	3.6V																																	
Red	DC5V	20mA	20mA	1.7V	2.4V																																	
Yellow	DC5V	20mA	20mA	1.9V	2.4V																																	
Blue	DC5V	20mA	20mA	3.0V	3.6V																																	
Green	DC5V	20mA	20mA	1.9V	2.4V																																	
2	<p>● LS8510</p> <p>Push No Sound No Lock Push No Lock Push To Lock Operating Type</p>	<p>Circuit Diagram</p> <p>PCB Layout Recommended</p>																																				

LAMP SERIES

8.5x8.5 Led Built-in Type

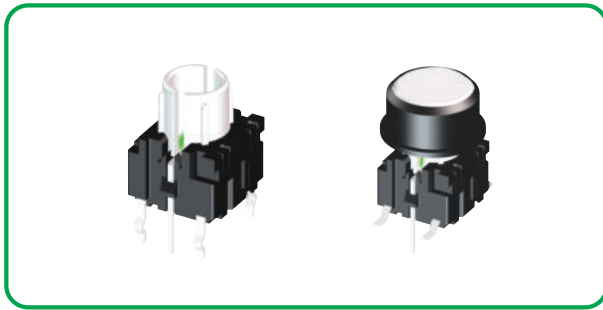

HOW TO ORDER

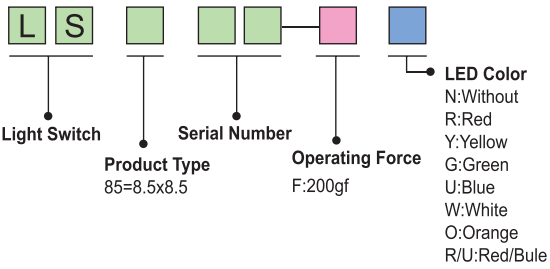

Specification

Items		Standard
Operating temperature range		-25°C to +85°C
Electrical performance	Rating	50mA, 30V DC
	Insulation resistance	100MΩ min. 250V DC
	Dielectric strength	AC250V(50-60Hz) for 1 min.
	Contact resistance	500mΩ max.
Durability	Lifetime	300,000 Cycles Min
Mechanical performance	Operating force	200 ± 50gf
	Travel	0.25 ± 0.1mm

Diagram

No.	Dimensions	Circuit Diagram																																				
		Pad Layout																																				
1	<p>● LS8511</p> <table border="1"> <thead> <tr> <th>Color</th> <th>VR</th> <th>IF</th> <th>Recommended Operating</th> <th>IF Norm</th> <th>IF Max</th> </tr> </thead> <tbody> <tr> <td>White</td> <td>DC5V</td> <td>20mA</td> <td>20mA</td> <td>3.0V</td> <td>3.6V</td> </tr> <tr> <td>Red</td> <td>DC5V</td> <td>20mA</td> <td>20mA</td> <td>1.7V</td> <td>2.4V</td> </tr> <tr> <td>Yellow</td> <td>DC5V</td> <td>20mA</td> <td>20mA</td> <td>1.9V</td> <td>2.4V</td> </tr> <tr> <td>Blue</td> <td>DC5V</td> <td>20mA</td> <td>20mA</td> <td>3.0V</td> <td>3.6V</td> </tr> <tr> <td>Green</td> <td>DC5V</td> <td>20mA</td> <td>20mA</td> <td>1.9V</td> <td>2.4V</td> </tr> </tbody> </table>	Color	VR	IF	Recommended Operating	IF Norm	IF Max	White	DC5V	20mA	20mA	3.0V	3.6V	Red	DC5V	20mA	20mA	1.7V	2.4V	Yellow	DC5V	20mA	20mA	1.9V	2.4V	Blue	DC5V	20mA	20mA	3.0V	3.6V	Green	DC5V	20mA	20mA	1.9V	2.4V	
Color	VR	IF	Recommended Operating	IF Norm	IF Max																																	
White	DC5V	20mA	20mA	3.0V	3.6V																																	
Red	DC5V	20mA	20mA	1.7V	2.4V																																	
Yellow	DC5V	20mA	20mA	1.9V	2.4V																																	
Blue	DC5V	20mA	20mA	3.0V	3.6V																																	
Green	DC5V	20mA	20mA	1.9V	2.4V																																	
2	<p>● LS8512</p>																																					

LAMP SERIES

10x10 Led Built-in Type

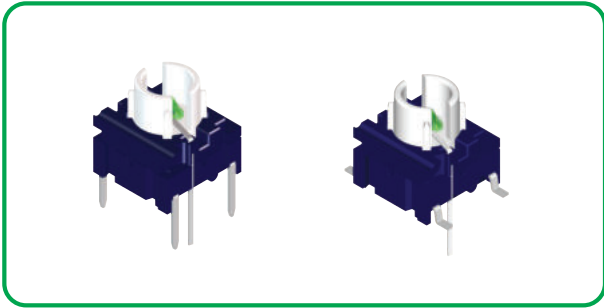

HOW TO ORDER

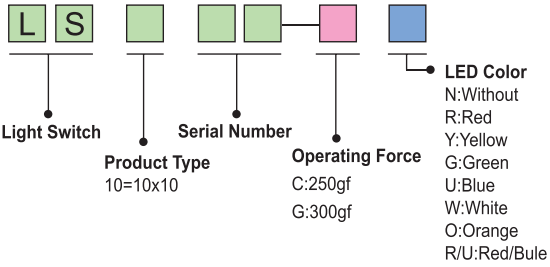

Specification

Items		Standard
Operating temperature range		-25°C to +85°C
Electrical performance	Rating	0.1A 30V DC
	Insulation resistance	100MΩ min. 250V DC
	Dielectric strength	AC250V(50-60Hz) for 1 min.
	Contact resistance	100mΩ max.
Durability	Lifetime	100,000 Cycles Min
Mechanical performance	Operating force	C:250gf G:300gf
	Travel	0.3 ± 0.1mm

LIGHT SWITCH

Diagram

No.	Dimensions	Circuit Diagram																																				
		Pad Layout																																				
1	<p>● LS1001</p> <table border="1"> <thead> <tr> <th>Color</th> <th>VR</th> <th>IF</th> <th>Recommended Operating</th> <th>IF Nom</th> <th>IF Max</th> </tr> </thead> <tbody> <tr> <td>White</td> <td>DC5V</td> <td>20mA</td> <td>20mA</td> <td>3.0V</td> <td>3.6V</td> </tr> <tr> <td>Red</td> <td>DC5V</td> <td>20mA</td> <td>20mA</td> <td>1.7V</td> <td>2.4V</td> </tr> <tr> <td>Yellow</td> <td>DC5V</td> <td>20mA</td> <td>20mA</td> <td>1.9V</td> <td>2.4V</td> </tr> <tr> <td>Blue</td> <td>DC5V</td> <td>20mA</td> <td>20mA</td> <td>3.0V</td> <td>3.6V</td> </tr> <tr> <td>Green</td> <td>DC5V</td> <td>20mA</td> <td>20mA</td> <td>1.9V</td> <td>2.4V</td> </tr> </tbody> </table>	Color	VR	IF	Recommended Operating	IF Nom	IF Max	White	DC5V	20mA	20mA	3.0V	3.6V	Red	DC5V	20mA	20mA	1.7V	2.4V	Yellow	DC5V	20mA	20mA	1.9V	2.4V	Blue	DC5V	20mA	20mA	3.0V	3.6V	Green	DC5V	20mA	20mA	1.9V	2.4V	
Color	VR	IF	Recommended Operating	IF Nom	IF Max																																	
White	DC5V	20mA	20mA	3.0V	3.6V																																	
Red	DC5V	20mA	20mA	1.7V	2.4V																																	
Yellow	DC5V	20mA	20mA	1.9V	2.4V																																	
Blue	DC5V	20mA	20mA	3.0V	3.6V																																	
Green	DC5V	20mA	20mA	1.9V	2.4V																																	
2	<p>● LS1002</p> <table border="1"> <thead> <tr> <th>Color</th> <th>VR</th> <th>IF</th> <th>Recommended Operating</th> <th>IF Nom</th> <th>IF Max</th> </tr> </thead> <tbody> <tr> <td>White</td> <td>DC5V</td> <td>20mA</td> <td>20mA</td> <td>3.0V</td> <td>3.6V</td> </tr> <tr> <td>Red</td> <td>DC5V</td> <td>20mA</td> <td>20mA</td> <td>1.7V</td> <td>2.4V</td> </tr> <tr> <td>Yellow</td> <td>DC5V</td> <td>20mA</td> <td>20mA</td> <td>1.9V</td> <td>2.4V</td> </tr> <tr> <td>Blue</td> <td>DC5V</td> <td>20mA</td> <td>20mA</td> <td>3.0V</td> <td>3.6V</td> </tr> <tr> <td>Green</td> <td>DC5V</td> <td>20mA</td> <td>20mA</td> <td>1.9V</td> <td>2.4V</td> </tr> </tbody> </table>	Color	VR	IF	Recommended Operating	IF Nom	IF Max	White	DC5V	20mA	20mA	3.0V	3.6V	Red	DC5V	20mA	20mA	1.7V	2.4V	Yellow	DC5V	20mA	20mA	1.9V	2.4V	Blue	DC5V	20mA	20mA	3.0V	3.6V	Green	DC5V	20mA	20mA	1.9V	2.4V	
Color	VR	IF	Recommended Operating	IF Nom	IF Max																																	
White	DC5V	20mA	20mA	3.0V	3.6V																																	
Red	DC5V	20mA	20mA	1.7V	2.4V																																	
Yellow	DC5V	20mA	20mA	1.9V	2.4V																																	
Blue	DC5V	20mA	20mA	3.0V	3.6V																																	
Green	DC5V	20mA	20mA	1.9V	2.4V																																	

LAMP SERIES

10x10 Led Built-in Type

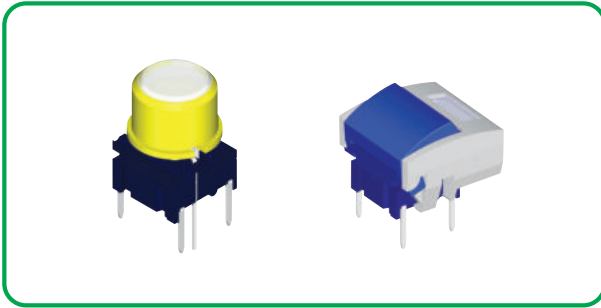

HOW TO ORDER

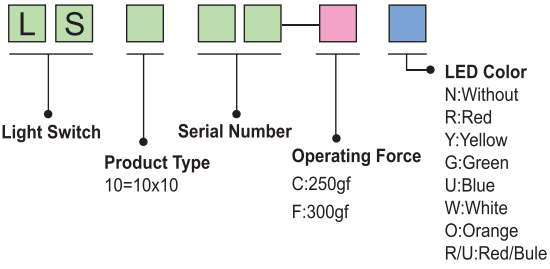

Specification

Items		Standard
Operating temperature range		-25°C to +85°C
Electrical performance	Rating	0.1A. 30V DC
	Insulation resistance	100MΩ min. 250V DC
	Dielectric strength	AC250V(50-60Hz) for 1 min.
	Contact resistance	100mΩ max.
Durability	Lifetime	100,000 Cycles Min
Mechanical performance	Operating force	C:250gf F:300gf
	Travel	0.3 ± 0.1mm

Diagram

No.	Dimensions	Circuit Diagram																														
		Pad Layout																														
1	<p>● LS1003</p> <table border="1"> <thead> <tr> <th>Color</th> <th>VR</th> <th>IF</th> <th>Recommended Operating</th> <th>IF Norm/Max</th> </tr> </thead> <tbody> <tr> <td>White</td> <td>DC5V</td> <td>20mA</td> <td>20mA</td> <td>3.0V/3.6V</td> </tr> <tr> <td>Red</td> <td>DC5V</td> <td>20mA</td> <td>20mA</td> <td>1.7V/2.4V</td> </tr> <tr> <td>Yellow</td> <td>DC5V</td> <td>20mA</td> <td>20mA</td> <td>1.9V/2.4V</td> </tr> <tr> <td>Blue</td> <td>DC5V</td> <td>20mA</td> <td>20mA</td> <td>3.0V/3.6V</td> </tr> <tr> <td>Green</td> <td>DC5V</td> <td>20mA</td> <td>20mA</td> <td>1.9V/2.4V</td> </tr> </tbody> </table>	Color	VR	IF	Recommended Operating	IF Norm/Max	White	DC5V	20mA	20mA	3.0V/3.6V	Red	DC5V	20mA	20mA	1.7V/2.4V	Yellow	DC5V	20mA	20mA	1.9V/2.4V	Blue	DC5V	20mA	20mA	3.0V/3.6V	Green	DC5V	20mA	20mA	1.9V/2.4V	
Color	VR	IF	Recommended Operating	IF Norm/Max																												
White	DC5V	20mA	20mA	3.0V/3.6V																												
Red	DC5V	20mA	20mA	1.7V/2.4V																												
Yellow	DC5V	20mA	20mA	1.9V/2.4V																												
Blue	DC5V	20mA	20mA	3.0V/3.6V																												
Green	DC5V	20mA	20mA	1.9V/2.4V																												
2	<p>● LS1004</p>																															

LAMP SERIES

10x10 Led Built-in Type

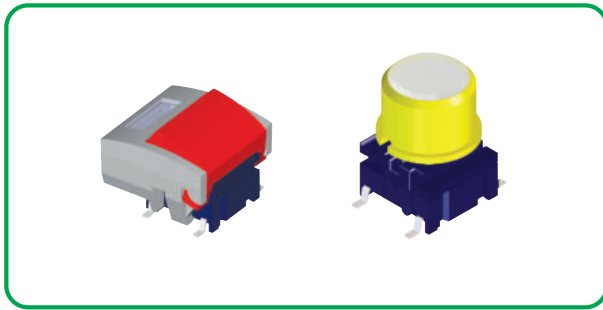

HOW TO ORDER

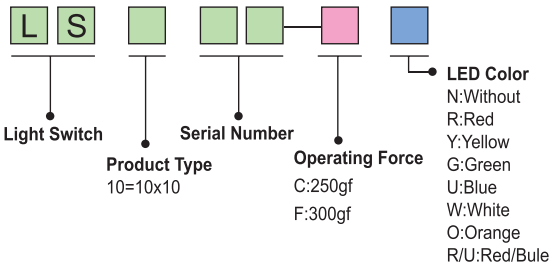

Specification

Items		Standard
Operating temperature range		-25°C to +85°C
Electrical performance	Rating	0.1A. 30V DC
	Insulation resistance	100MΩ min. 250V DC
	Dielectric strength	AC250V(50-60Hz) for 1 min.
	Contact resistance	100mΩ max.
Durability	Lifetime	100,000 Cycles Min
Mechanical performance	Operating force	C:250gf F:300gf
	Travel	0.3 ± 0.1mm

LIGHT SWITCH

Diagram

No.	Dimensions	Circuit Diagram
		Pad Layout
1	<p>● LS1005</p>	
2	<p>● LS1006</p>	

LAMP SERIES

12.0x12.0 With Light Tact Switch



HOW TO ORDER

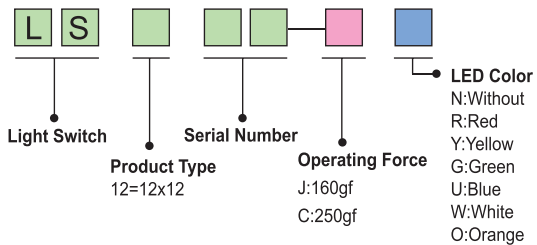

Specification

Items		Standard
Operating temperature range		-10°C to +60°C
Electrical performance	Rating	50mA. 12V DC
	Insulation resistance	100MΩ min. 100V DC
	Dielectric strength	250V AC for 1 min.
	Contact resistance	100mΩ max.
Durability	Lifetime	100,000 Cycles min
Mechanical performance	Operating force	J:160gf C:250gf
	Travel	0.3 ± 0.1mm

LED Data

Peak Reverse Voltage	See ordering guide
Max. Forward Current	20mA
Color	IF Forward Direct Current (mA)
Yellow	25
Red	25
Green	25

VF Forward Voltage (v) TYP.	NN Peak Emission Wavelength(nm)
4.2	630
4.2	565
4.2	589

Diagram

No.	Dimensions	Circuit Diagram
		Pad Layout
1	<p>● LS1201</p>	

LAMP SERIES

12x12 Led Built-in Type

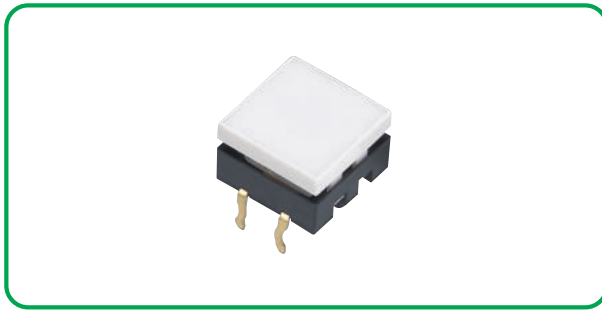

HOW TO ORDER

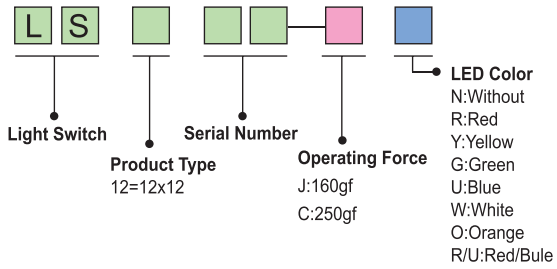

Specification

Items		Standard
Operating temperature range		-25°C to +85°C
Electrical performance	Rating	100mA, 30V DC
	Insulation resistance	100MΩ min. 100V DC
	Dielectric strength	250V AC for 1 min.
	Contact resistance	100mΩ max.
Durability	Lifetime	100,000 Cycles Min
Mechanical performance	Operating force	J:160gf C:250gf
	Travel	0.3 ± 0.1mm

LIGHT SWITCH

Diagram

No.	Dimensions	Circuit Diagram
		Pad Layout
1	<p>● LS1202</p>	
2	<p>● LS1203</p>	

04

PUSH SWITCH SERIES

Features:

- There are many dimensions available, such as:
- The switch sounds silvery, feeling and rhythm are perfect.
- Contact ways: SPDT & DPDT.
- There are 2 operating modes: Self-Lock and Non-Lock.
- The state of terminals and height of pushbutton can be designed according to customer's requirements.

Applications:

The push button switches can operate computer ancillary equipment, TV, audio equipment, all kinds of small autoimmunization equipment and instruments etc.

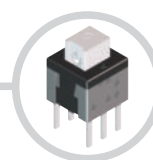
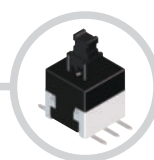
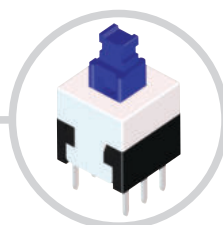
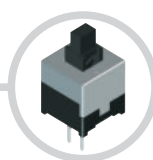
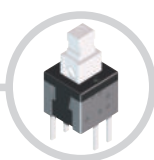

PUSH BUTTON SERIES

5.8x5.8 Push Switch

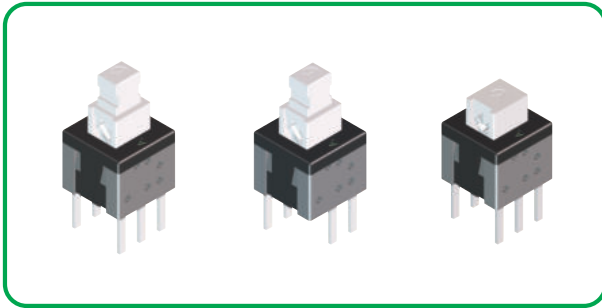

HOW TO ORDER

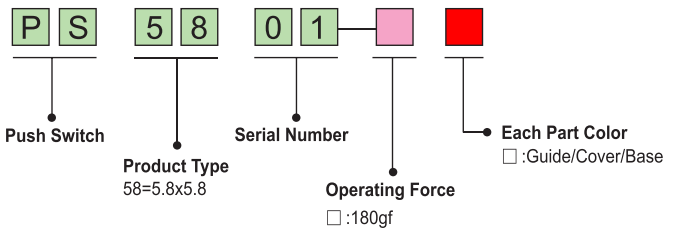

Specification

Items		Standard
Operating temperature range		-30°C to +85°C
Electrical performance	Rating	10mA, 30V DC
	Insulation resistance	100MΩ min. 500V DC
	Dielectric strength	250V AC for 1 min.
	Contact resistance	100mΩ max.
Durability	Lifetime	10,000 Cycles min.
Operating force		180gf

Diagram

No.	Dimensions	Circuit Diagram								
1	<p>● PS5801</p> <table border="1"> <tr><td>PS5803</td><td>Push No Sound No Lock</td></tr> <tr><td>PS5802</td><td>Push No Lock</td></tr> <tr><td>PS5801</td><td>Push To Lock</td></tr> <tr><td>PartNo</td><td>Operating Type</td></tr> </table>	PS5803	Push No Sound No Lock	PS5802	Push No Lock	PS5801	Push To Lock	PartNo	Operating Type	<p>Circuit Diagram</p> <p>PCB Layout Recommended</p>
PS5803	Push No Sound No Lock									
PS5802	Push No Lock									
PS5801	Push To Lock									
PartNo	Operating Type									
2	<p>● PS5804</p> <table border="1"> <tr><td>PS5806</td><td>Push No Sound No Lock</td></tr> <tr><td>PS5805</td><td>Push No Lock</td></tr> <tr><td>PS5804</td><td>Push To Lock</td></tr> <tr><td>PartNo</td><td>Operating Type</td></tr> </table>	PS5806	Push No Sound No Lock	PS5805	Push No Lock	PS5804	Push To Lock	PartNo	Operating Type	<p>Circuit Diagram</p> <p>PCB Layout Recommended</p>
PS5806	Push No Sound No Lock									
PS5805	Push No Lock									
PS5804	Push To Lock									
PartNo	Operating Type									
3	<p>● PS5807</p> <table border="1"> <tr><td>PS5809</td><td>Push No Sound No Lock</td></tr> <tr><td>PS5808</td><td>Push No Lock</td></tr> <tr><td>PS5807</td><td>Push To Lock</td></tr> <tr><td>PartNo</td><td>Operating Type</td></tr> </table>	PS5809	Push No Sound No Lock	PS5808	Push No Lock	PS5807	Push To Lock	PartNo	Operating Type	<p>Circuit Diagram</p> <p>PCB Layout Recommended</p>
PS5809	Push No Sound No Lock									
PS5808	Push No Lock									
PS5807	Push To Lock									
PartNo	Operating Type									

PUSH BUTTON SERIES

7x7 Push Switch

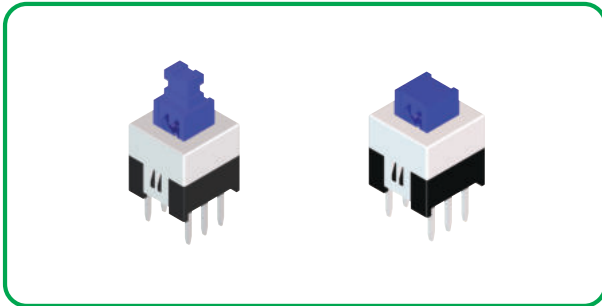

HOW TO ORDER

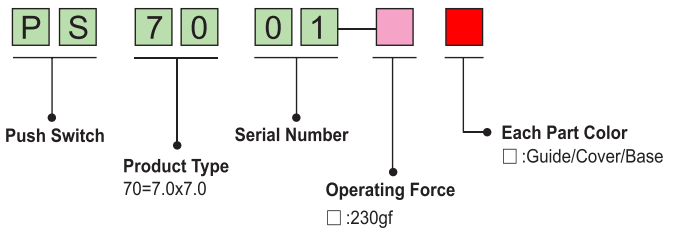

Specification

Items		Standard
Operating temperature range		-30℃ to +85℃
Electrical performance	Rating	10mA. 30V DC
	Insulation resistance	100MΩ min. 500V DC
	Dielectric strength	250V AC for 1 min.
	Contact resistance	100mΩ max.
Durability	Lifetime	10,000 Cycles min.
Operating force		230gf

Diagram

No.	Dimensions	Circuit Diagram								
1	<p>● PS7001</p> <table border="1"> <tr><td>PS7003</td><td>Push No Sound No Lock</td></tr> <tr><td>PS7002</td><td>Push No Lock</td></tr> <tr><td>PS7001</td><td>Push To Lock</td></tr> <tr><td>Part No</td><td>Operating Type</td></tr> </table>	PS7003	Push No Sound No Lock	PS7002	Push No Lock	PS7001	Push To Lock	Part No	Operating Type	<p>Circuit Diagram</p> <p>PCB Layout Recommended</p>
PS7003	Push No Sound No Lock									
PS7002	Push No Lock									
PS7001	Push To Lock									
Part No	Operating Type									
2	<p>● PS7004</p> <table border="1"> <tr><td>PS7006</td><td>Push No Sound No Lock</td></tr> <tr><td>PS7005</td><td>Push No Lock</td></tr> <tr><td>PS7004</td><td>Push To Lock</td></tr> <tr><td>Part No</td><td>Operating Type</td></tr> </table>	PS7006	Push No Sound No Lock	PS7005	Push No Lock	PS7004	Push To Lock	Part No	Operating Type	<p>Circuit Diagram</p> <p>PCB Layout Recommended</p>
PS7006	Push No Sound No Lock									
PS7005	Push No Lock									
PS7004	Push To Lock									
Part No	Operating Type									

PUSH BUTTON SERIES

8x8 Push Switch

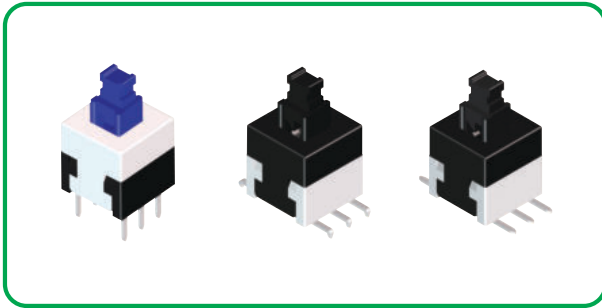

HOW TO ORDER

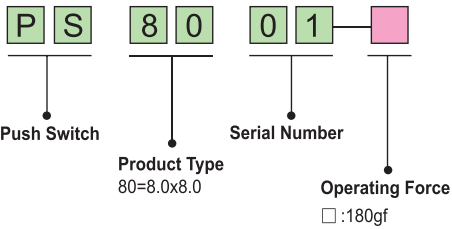

Specification

Items		Standard
Operating temperature range		-30℃ to +85℃
Electrical performance	Rating	10mA. 30V DC
	Insulation resistance	100MΩ min. 500V DC
	Dielectric strength	250V AC for 1 min.
	Contact resistance	100mΩ max.
Durability	Lifetime	10,000 Cycles min.
Operating force		180gf

Diagram

No.	Dimensions	Circuit Diagram																				
1	<p>● PS8001</p> <table border="1"> <tr><td>Push No Sound No Lock</td><td>PS8003</td><td>White</td><td>Black</td><td>White</td></tr> <tr><td>Push No Lock</td><td>PS8002</td><td>White</td><td>Black</td><td>Black</td></tr> <tr><td>Push To Lock</td><td>PS8001</td><td>Black</td><td>White</td><td>Blue</td></tr> <tr><td>Operating Type</td><td>PartNo</td><td>Color base</td><td>Rear cover color</td><td>Guide core color</td></tr> </table>	Push No Sound No Lock	PS8003	White	Black	White	Push No Lock	PS8002	White	Black	Black	Push To Lock	PS8001	Black	White	Blue	Operating Type	PartNo	Color base	Rear cover color	Guide core color	<p>Circuit Diagram</p> <p>PCB Layout Recommended</p>
Push No Sound No Lock	PS8003	White	Black	White																		
Push No Lock	PS8002	White	Black	Black																		
Push To Lock	PS8001	Black	White	Blue																		
Operating Type	PartNo	Color base	Rear cover color	Guide core color																		
2	<p>● PS8004</p> <table border="1"> <tr><td>Push No Sound No Lock</td><td>PS8006</td><td>White</td><td>Black</td><td>White</td></tr> <tr><td>Push No Lock</td><td>PS8005</td><td>White</td><td>Black</td><td>Black</td></tr> <tr><td>Push To Lock</td><td>PS8004</td><td>Black</td><td>White</td><td>Blue</td></tr> <tr><td>Operating Type</td><td>PartNo</td><td>Color base</td><td>Rear cover color</td><td>Guide core color</td></tr> </table>	Push No Sound No Lock	PS8006	White	Black	White	Push No Lock	PS8005	White	Black	Black	Push To Lock	PS8004	Black	White	Blue	Operating Type	PartNo	Color base	Rear cover color	Guide core color	<p>Circuit Diagram</p> <p>PCB Layout Recommended</p>
Push No Sound No Lock	PS8006	White	Black	White																		
Push No Lock	PS8005	White	Black	Black																		
Push To Lock	PS8004	Black	White	Blue																		
Operating Type	PartNo	Color base	Rear cover color	Guide core color																		
3	<p>● PS8007</p> <table border="1"> <tr><td>Push No Sound No Lock</td><td>PS8009</td><td>White</td><td>Black</td><td>White</td></tr> <tr><td>Push No Lock</td><td>PS8008</td><td>White</td><td>Black</td><td>Black</td></tr> <tr><td>Push To Lock</td><td>PS8007</td><td>Black</td><td>White</td><td>Blue</td></tr> <tr><td>Operating Type</td><td>PartNo</td><td>Color base</td><td>Rear cover color</td><td>Guide core color</td></tr> </table>	Push No Sound No Lock	PS8009	White	Black	White	Push No Lock	PS8008	White	Black	Black	Push To Lock	PS8007	Black	White	Blue	Operating Type	PartNo	Color base	Rear cover color	Guide core color	<p>Circuit Diagram</p> <p>PCB Layout Recommended</p>
Push No Sound No Lock	PS8009	White	Black	White																		
Push No Lock	PS8008	White	Black	Black																		
Push To Lock	PS8007	Black	White	Blue																		
Operating Type	PartNo	Color base	Rear cover color	Guide core color																		

PUSH BUTTON SERIES

8.45x8.45 Push Switch

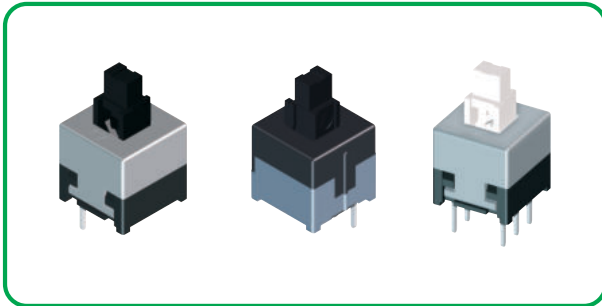

HOW TO ORDER

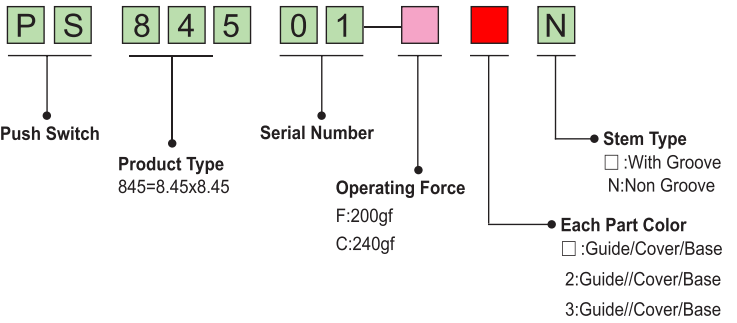

Specification

Items	Standard	
Operating temperature range	-30°C to +85°C	
Electrical performance	Rating	10mA, 30V DC
	Insulation resistance	100MΩ min. 500V DC
	Dielectric strength	500V AC for 1 min.
	Contact resistance	100mΩ max.
Durability	Lifetime	10,000 Cycles min.
	Operating force	F:200gf C:240gf

Diagram

No.	Dimensions	Circuit Diagram								
1	<p>● PS84501</p> <table border="1"> <tr> <td>PS84503</td> <td>Push No Sound No Lock</td> </tr> <tr> <td>PS84502</td> <td>Push No Lock</td> </tr> <tr> <td>PS84501</td> <td>Push To Lock</td> </tr> <tr> <td>Part No</td> <td>Operating Type</td> </tr> </table>	PS84503	Push No Sound No Lock	PS84502	Push No Lock	PS84501	Push To Lock	Part No	Operating Type	<p>Circuit Diagram</p> <p>PCB Layout Recommended</p>
PS84503	Push No Sound No Lock									
PS84502	Push No Lock									
PS84501	Push To Lock									
Part No	Operating Type									
2	<p>● PS84504</p> <table border="1"> <tr> <td>PS84506</td> <td>Push No Sound No Lock</td> </tr> <tr> <td>PS84505</td> <td>Push No Lock</td> </tr> <tr> <td>PS84504</td> <td>Push To Lock</td> </tr> <tr> <td>Part No</td> <td>Operating Type</td> </tr> </table>	PS84506	Push No Sound No Lock	PS84505	Push No Lock	PS84504	Push To Lock	Part No	Operating Type	<p>Circuit Diagram</p> <p>PCB Layout Recommended</p>
PS84506	Push No Sound No Lock									
PS84505	Push No Lock									
PS84504	Push To Lock									
Part No	Operating Type									
3	<p>● PS84507</p> <table border="1"> <tr> <td>PS84509</td> <td>Push No Sound No Lock</td> </tr> <tr> <td>PS84508</td> <td>Push No Lock</td> </tr> <tr> <td>PS84507</td> <td>Push To Lock</td> </tr> <tr> <td>Part No</td> <td>Operating Type</td> </tr> </table>	PS84509	Push No Sound No Lock	PS84508	Push No Lock	PS84507	Push To Lock	Part No	Operating Type	<p>Circuit Diagram</p> <p>PCB Layout Recommended</p>
PS84509	Push No Sound No Lock									
PS84508	Push No Lock									
PS84507	Push To Lock									
Part No	Operating Type									

PUSH BUTTON SERIES

8.5x8.5 Push Switch

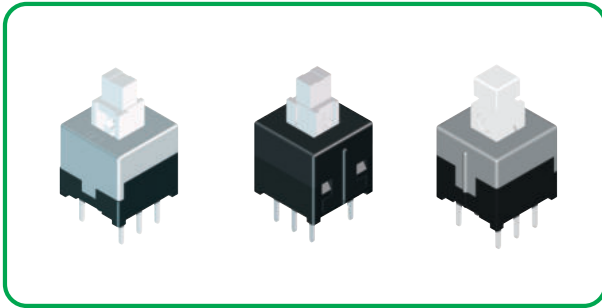

HOW TO ORDER

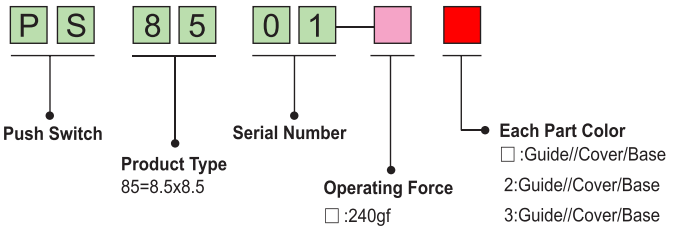

Specification

Items	Standard	
Operating temperature range	-30°C to +85°C	
Electrical performance	Rating	10mA, 30V DC
	Insulation resistance	100MΩ min. 500V DC
	Dielectric strength	500V AC for 1 min.
	Contact resistance	100mΩ max.
Durability	Lifetime	10,000 Cycles min.
	Operating force	240gf

Diagram

No.	Dimensions	Circuit Diagram								
1	<p>● PS8501</p> <table border="1"> <tr><td>PS8503</td><td>Push No Sound No Lock</td></tr> <tr><td>PS8502</td><td>Push No Lock</td></tr> <tr><td>PS8501</td><td>Push To Lock</td></tr> <tr><td>Part No</td><td>Operating Type</td></tr> </table>	PS8503	Push No Sound No Lock	PS8502	Push No Lock	PS8501	Push To Lock	Part No	Operating Type	<p>Circuit Diagram</p> <p>PCB Layout Recommended</p>
PS8503	Push No Sound No Lock									
PS8502	Push No Lock									
PS8501	Push To Lock									
Part No	Operating Type									
2	<p>● PS8504</p> <table border="1"> <tr><td>PS8506</td><td>Push No Sound No Lock</td></tr> <tr><td>PS8505</td><td>Push No Lock</td></tr> <tr><td>PS8504</td><td>Push To Lock</td></tr> <tr><td>Part No</td><td>Operating Type</td></tr> </table>	PS8506	Push No Sound No Lock	PS8505	Push No Lock	PS8504	Push To Lock	Part No	Operating Type	<p>Circuit Diagram</p> <p>PCB Layout Recommended</p>
PS8506	Push No Sound No Lock									
PS8505	Push No Lock									
PS8504	Push To Lock									
Part No	Operating Type									
3	<p>● PS8507</p> <table border="1"> <tr><td>PS8509</td><td>Push No Sound No Lock</td></tr> <tr><td>PS8508</td><td>Push No Lock</td></tr> <tr><td>PS8507</td><td>Push To Lock</td></tr> <tr><td>Part No</td><td>Operating Type</td></tr> </table>	PS8509	Push No Sound No Lock	PS8508	Push No Lock	PS8507	Push To Lock	Part No	Operating Type	<p>Circuit Diagram</p> <p>PCB Layout Recommended</p>
PS8509	Push No Sound No Lock									
PS8508	Push No Lock									
PS8507	Push To Lock									
Part No	Operating Type									

PUSH BUTTON SERIES

8.5x8.5 Push Switch

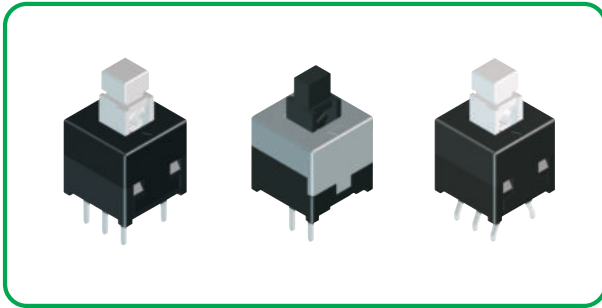

HOW TO ORDER

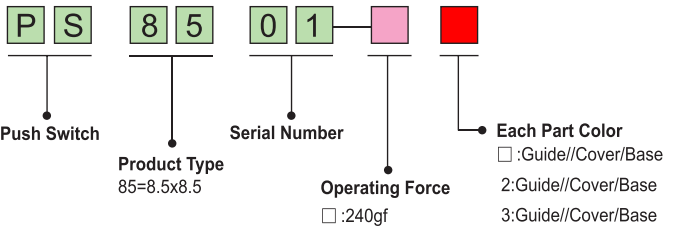

Specification

Items	Standard	
Operating temperature range	-30°C to +85°C	
Electrical performance	Rating	10mA, 30V DC
	Insulation resistance	100MΩ min. 500V DC
	Dielectric strength	500V AC for 1 min.
	Contact resistance	100mΩ max.
Durability	Lifetime	10,000 Cycles min.
	Operating force	240gf

Diagram

No.	Dimensions	Circuit Diagram								
1	<p>● PS8510</p> <table border="1"> <tr> <td>PS8512</td> <td>Push No Sound No Lock</td> </tr> <tr> <td>PS8511</td> <td>Push No Lock</td> </tr> <tr> <td>PS8510</td> <td>Push To Lock</td> </tr> <tr> <td>Part No</td> <td>Operating Type</td> </tr> </table>	PS8512	Push No Sound No Lock	PS8511	Push No Lock	PS8510	Push To Lock	Part No	Operating Type	<p>Circuit Diagram</p> <p>PCB Layout Recommended</p>
PS8512	Push No Sound No Lock									
PS8511	Push No Lock									
PS8510	Push To Lock									
Part No	Operating Type									
2	<p>● PS8513</p> <table border="1"> <tr> <td>PS8515</td> <td>Push No Sound No Lock</td> </tr> <tr> <td>PS8514</td> <td>Push No Lock</td> </tr> <tr> <td>PS8513</td> <td>Push To Lock</td> </tr> <tr> <td>Part No</td> <td>Operating Type</td> </tr> </table>	PS8515	Push No Sound No Lock	PS8514	Push No Lock	PS8513	Push To Lock	Part No	Operating Type	<p>Circuit Diagram</p> <p>PCB Layout Recommended</p>
PS8515	Push No Sound No Lock									
PS8514	Push No Lock									
PS8513	Push To Lock									
Part No	Operating Type									
3	<p>● PS8516</p> <table border="1"> <tr> <td>PS8518</td> <td>Push No Sound No Lock</td> </tr> <tr> <td>PS8517</td> <td>Push No Lock</td> </tr> <tr> <td>PS8516</td> <td>Push To Lock</td> </tr> <tr> <td>Part No</td> <td>Operating Type</td> </tr> </table>	PS8518	Push No Sound No Lock	PS8517	Push No Lock	PS8516	Push To Lock	Part No	Operating Type	<p>Circuit Diagram</p> <p>PCB Layout Recommended</p>
PS8518	Push No Sound No Lock									
PS8517	Push No Lock									
PS8516	Push To Lock									
Part No	Operating Type									

PUSH BUTTON SERIES

8.5x8.5 Push Switch

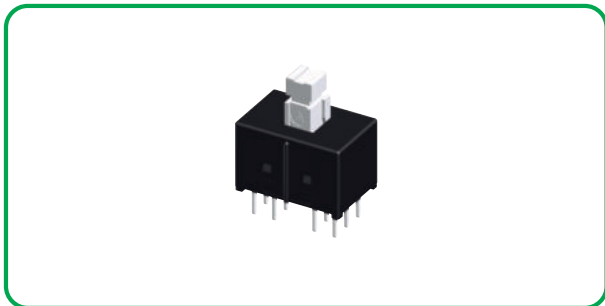

HOW TO ORDER

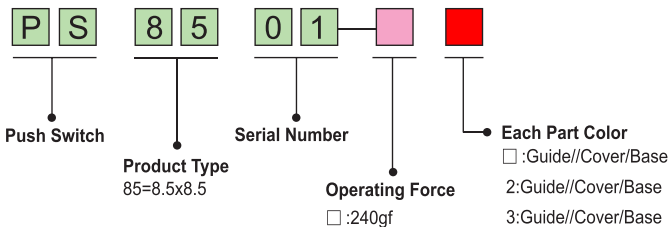

Specification

Items		Standard
Operating temperature range		-30°C to +85°C
Electrical performance	Rating	10mA, 30V DC
	Insulation resistance	100MΩ min. 500V DC
	Dielectric strength	500V AC for 1 min.
	Contact resistance	100mΩ max.
Durability	Lifetime	10,000 Cycles min.
Operating force		240gf

Diagram

No.	Dimensions	Circuit Diagram								
1	<p>● PS8519</p> <table border="1" style="margin-left: auto; margin-right: auto;"> <tr> <td>PS8521</td> <td>Push No Sound No Lock</td> </tr> <tr> <td>PS8520</td> <td>Push No Lock</td> </tr> <tr> <td>PS8519</td> <td>Push To Lock</td> </tr> <tr> <td>Part No</td> <td>Operating Type</td> </tr> </table>	PS8521	Push No Sound No Lock	PS8520	Push No Lock	PS8519	Push To Lock	Part No	Operating Type	<p>Circuit Diagram</p> <p>PCB Layout Recommended</p>
PS8521	Push No Sound No Lock									
PS8520	Push No Lock									
PS8519	Push To Lock									
Part No	Operating Type									

PUSH BUTTON SERIES

12x12 Push Switch

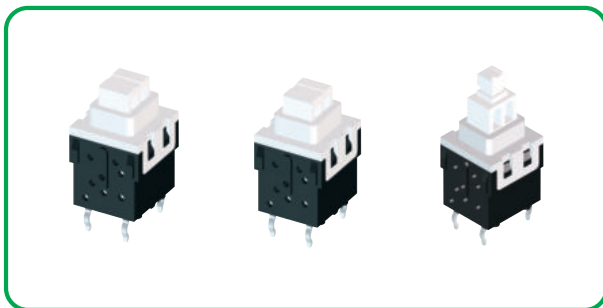

HOW TO ORDER

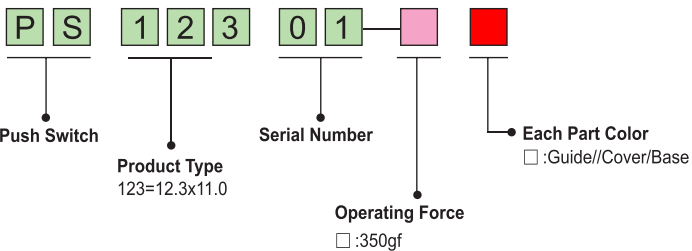

Specification

Items		Standard
Operating temperature range		-30°C to +85°C
Electrical performance	Rating	10mA. 30V DC
	Insulation resistance	100MΩ min. 500V DC
	Dielectric strength	250V AC for 1 min.
	Contact resistance	100mΩ max.
Durability	Lifetime	10,000 Cycles min.
Operating force		350gf

Diagram

No.	Dimensions	Circuit Diagram								
1	<p>● PS12301</p> <table border="1"> <tr> <td>PS12302</td> <td>Push No Lock</td> </tr> <tr> <td>PS12301</td> <td>Push To Lock</td> </tr> <tr> <td>PartNo</td> <td>Operating Type</td> </tr> </table>	PS12302	Push No Lock	PS12301	Push To Lock	PartNo	Operating Type	<p>Circuit Diagram</p> <p>PCB Layout Recommended</p>		
PS12302	Push No Lock									
PS12301	Push To Lock									
PartNo	Operating Type									
2	<p>● PS12303</p> <table border="1"> <tr> <td>PS12304</td> <td>Push No Lock</td> </tr> <tr> <td>PS12303</td> <td>Push To Lock</td> </tr> <tr> <td>PartNo</td> <td>Operating Type</td> </tr> </table>	PS12304	Push No Lock	PS12303	Push To Lock	PartNo	Operating Type	<p>Circuit Diagram</p> <p>PCB Layout Recommended</p>		
PS12304	Push No Lock									
PS12303	Push To Lock									
PartNo	Operating Type									
3	<p>● PS12305</p> <table border="1"> <tr> <td>PS12307</td> <td>Push No Sound No Lock</td> </tr> <tr> <td>PS12306</td> <td>Push No Lock</td> </tr> <tr> <td>PS12305</td> <td>Push To Lock</td> </tr> <tr> <td>PartNo</td> <td>Operating Type</td> </tr> </table>	PS12307	Push No Sound No Lock	PS12306	Push No Lock	PS12305	Push To Lock	PartNo	Operating Type	<p>Circuit Diagram</p> <p>PCB Layout Recommended</p>
PS12307	Push No Sound No Lock									
PS12306	Push No Lock									
PS12305	Push To Lock									
PartNo	Operating Type									

ROTARY CODED SWITCH SERIES

05

Features:

- Molded-in terminals and fully sealed construction.
- All plastics are UL 94V-0 grade fire retardant.
- Reliable contact and long-term stability.
- Binary decimal (8 or 10 positions) and hexadecimal (16 positions), real and complementary codes available.
- Pin-out is compatible with most of current equivalents.
- Gold plated contact to ensure low contact resistance.

Applications:

- Address switching applications.
- Data storage devices.
- Computer and peripherals.
- Instrumentation.

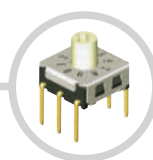
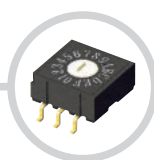
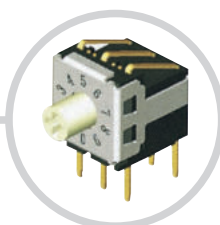
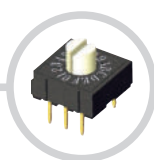

RS SERIES

10x10mm Rotary Type

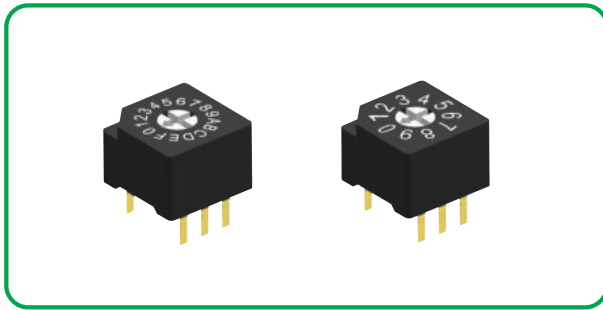

HOW TO ORDER

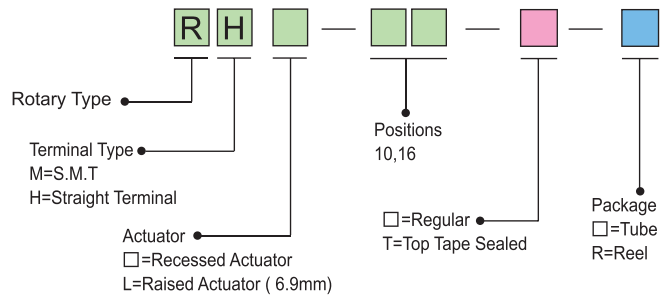

Specification

Items		Standard	Package Tube:50pcs/tube
Environmental	Operation Temperature Range	-25℃ to +70℃	
	Storage Temperature Range	-40℃ to +85℃	
Electrical performance	Electrical Life	2,000 Steps	
	Non-Switching Rating	100mA,50VDC	
	Switching Rating	25mA,24VDC	
Mechanical performance	Operating force	500gf-cm max	

Diagram

No.	Dimensions	Circuit Diagram																																																																																																		
		Pad Layout																																																																																																		
1	<p>● RH-16</p>	<p>Output Coding</p> <table border="1"> <thead> <tr> <th rowspan="2">TYPE</th> <th rowspan="2">POSITION</th> <th colspan="4">CODE</th> </tr> <tr> <th>1</th> <th>2</th> <th>4</th> <th>8</th> </tr> </thead> <tbody> <tr><td rowspan="10">O 10</td><td>0</td><td></td><td></td><td></td><td></td></tr> <tr><td>1</td><td>●</td><td></td><td></td><td></td></tr> <tr><td>2</td><td></td><td>●</td><td></td><td></td></tr> <tr><td>3</td><td>●</td><td>●</td><td></td><td></td></tr> <tr><td>4</td><td></td><td></td><td>●</td><td></td></tr> <tr><td>5</td><td>●</td><td></td><td></td><td></td></tr> <tr><td>6</td><td></td><td>●</td><td>●</td><td></td></tr> <tr><td>7</td><td>●</td><td>●</td><td>●</td><td></td></tr> <tr><td>8</td><td></td><td></td><td></td><td>●</td></tr> <tr><td>9</td><td>●</td><td></td><td></td><td>●</td></tr> <tr><td>A</td><td></td><td>●</td><td></td><td>●</td></tr> <tr><td>B</td><td>●</td><td>●</td><td></td><td>●</td></tr> <tr><td>C</td><td></td><td></td><td>●</td><td>●</td></tr> <tr><td rowspan="4">O 16</td><td>D</td><td>●</td><td></td><td>●</td><td>●</td></tr> <tr><td>E</td><td></td><td>●</td><td>●</td><td>●</td></tr> <tr><td>F</td><td>●</td><td>●</td><td>●</td><td>●</td></tr> <tr><td></td><td>●</td><td>●</td><td>●</td><td>●</td></tr> </tbody> </table>		TYPE	POSITION	CODE				1	2	4	8	O 10	0					1	●				2		●			3	●	●			4			●		5	●				6		●	●		7	●	●	●		8				●	9	●			●	A		●		●	B	●	●		●	C			●	●	O 16	D	●		●	●	E		●	●	●	F	●	●	●	●		●	●	●	●
TYPE	POSITION	CODE																																																																																																		
		1	2	4	8																																																																																															
O 10	0																																																																																																			
	1	●																																																																																																		
	2		●																																																																																																	
	3	●	●																																																																																																	
	4			●																																																																																																
	5	●																																																																																																		
	6		●	●																																																																																																
	7	●	●	●																																																																																																
	8				●																																																																																															
	9	●			●																																																																																															
A		●		●																																																																																																
B	●	●		●																																																																																																
C			●	●																																																																																																
O 16	D	●		●	●																																																																																															
	E		●	●	●																																																																																															
	F	●	●	●	●																																																																																															
		●	●	●	●																																																																																															
2	<p>● RH-10</p>																																																																																																			

ROTARY CODED SWITCH

RS SERIES

10x10mm Rotary Type

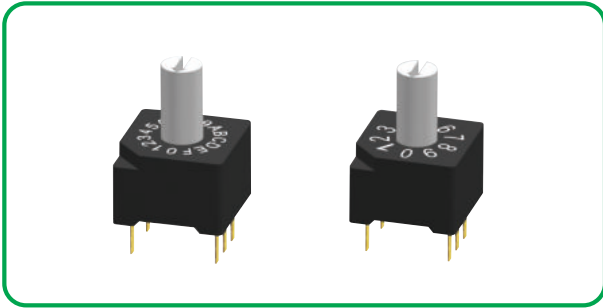

HOW TO ORDER

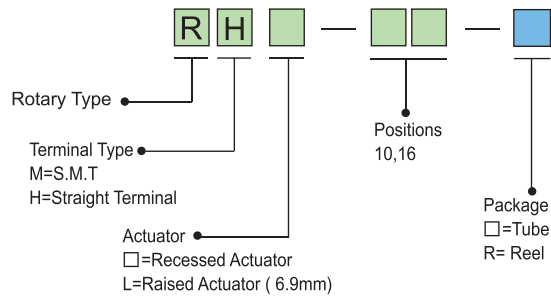

Specification

Items		Standard	Package Tube:50pcs/tube
Environmental	Operation Temperature Range	-25℃ to +70℃	
	Storage Temperature Range	-40℃ to +85℃	
Electrical performance	Electrical Life	2,000 Steps	
	Non-Switching Rating	100mA,50VDC	
	Switching Rating	25mA,24VDC	
Mechanical performance	Operating force	500gf-cm max	

Diagram

No.	Dimensions	Circuit Diagram																																																																																																	
		Pad Layout																																																																																																	
1	<p>● RHL-16</p>	<table border="1"> <thead> <tr> <th colspan="5">Output Coding</th> </tr> <tr> <th rowspan="2">TYPE</th> <th rowspan="2">POSITION</th> <th colspan="4">CODE</th> </tr> <tr> <th>1</th> <th>2</th> <th>4</th> <th>8</th> </tr> </thead> <tbody> <tr><td rowspan="10">O 10</td><td>0</td><td></td><td></td><td></td><td></td></tr> <tr><td>1</td><td>●</td><td></td><td></td><td></td></tr> <tr><td>2</td><td></td><td>●</td><td></td><td></td></tr> <tr><td>3</td><td>●</td><td>●</td><td></td><td></td></tr> <tr><td>4</td><td></td><td></td><td>●</td><td></td></tr> <tr><td>5</td><td>●</td><td></td><td></td><td></td></tr> <tr><td>6</td><td></td><td>●</td><td>●</td><td></td></tr> <tr><td>7</td><td>●</td><td>●</td><td>●</td><td></td></tr> <tr><td>8</td><td></td><td></td><td></td><td>●</td></tr> <tr><td>9</td><td>●</td><td></td><td></td><td></td></tr> <tr><td rowspan="6">O 16</td><td>A</td><td>●</td><td>●</td><td></td><td>●</td></tr> <tr><td>B</td><td>●</td><td>●</td><td>●</td><td>●</td></tr> <tr><td>C</td><td></td><td></td><td>●</td><td>●</td></tr> <tr><td>D</td><td>●</td><td></td><td>●</td><td>●</td></tr> <tr><td>E</td><td>●</td><td>●</td><td>●</td><td>●</td></tr> <tr><td>F</td><td>●</td><td>●</td><td>●</td><td>●</td></tr> </tbody> </table>	Output Coding					TYPE	POSITION	CODE				1	2	4	8	O 10	0					1	●				2		●			3	●	●			4			●		5	●				6		●	●		7	●	●	●		8				●	9	●				O 16	A	●	●		●	B	●	●	●	●	C			●	●	D	●		●	●	E	●	●	●	●	F	●	●	●	●
Output Coding																																																																																																			
TYPE	POSITION	CODE																																																																																																	
		1	2	4	8																																																																																														
O 10	0																																																																																																		
	1	●																																																																																																	
	2		●																																																																																																
	3	●	●																																																																																																
	4			●																																																																																															
	5	●																																																																																																	
	6		●	●																																																																																															
	7	●	●	●																																																																																															
	8				●																																																																																														
	9	●																																																																																																	
O 16	A	●	●		●																																																																																														
	B	●	●	●	●																																																																																														
	C			●	●																																																																																														
	D	●		●	●																																																																																														
	E	●	●	●	●																																																																																														
	F	●	●	●	●																																																																																														
2	<p>● RHL-10</p>																																																																																																		

RS SERIES

10x10mm Selector Rotary Type

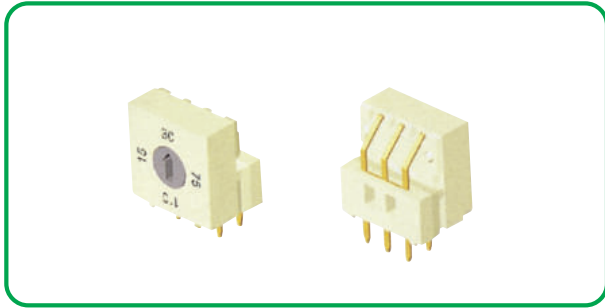

HOW TO ORDER

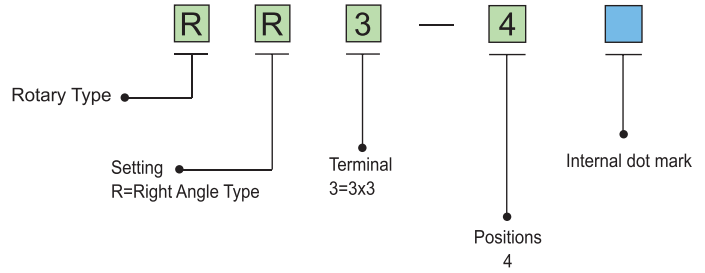

Specification

Items		Standard	Package Tube:48pcs/tube
Environmental	Operation Temperature Range	-25℃ to +80℃	
	Storage Temperature Range	-40℃ to +85℃	
Electrical performance	Electrical Life	20,000 steps	
	Non-Switching Rating	100mA,50VDC	
	Switching Rating	25mA,24VDC	
Mechanical performance	Operating force	200gf-cm max	

Diagram

No.	Dimensions	Circuit Diagram																													
		Pad Layout																													
1	<p>● RR3-4</p>	<table border="1"> <thead> <tr> <th rowspan="2">POSITION</th> <th colspan="4">CODE</th> </tr> <tr> <th>15</th> <th>30</th> <th>75</th> <th>110</th> </tr> </thead> <tbody> <tr> <td>15</td> <td>○</td> <td>○</td> <td>○</td> <td>○</td> </tr> <tr> <td>30</td> <td>●</td> <td>○</td> <td>●</td> <td>●</td> </tr> <tr> <td>75</td> <td>●</td> <td>○</td> <td>○</td> <td>○</td> </tr> <tr> <td>110</td> <td>●</td> <td>●</td> <td>●</td> <td>○</td> </tr> </tbody> </table> <p>Circuit Chart</p> <p>P.C.B. Layout</p>	POSITION	CODE				15	30	75	110	15	○	○	○	○	30	●	○	●	●	75	●	○	○	○	110	●	●	●	○
POSITION	CODE																														
	15	30	75	110																											
15	○	○	○	○																											
30	●	○	●	●																											
75	●	○	○	○																											
110	●	●	●	○																											

RS SERIES

10x10mm Rotary Type

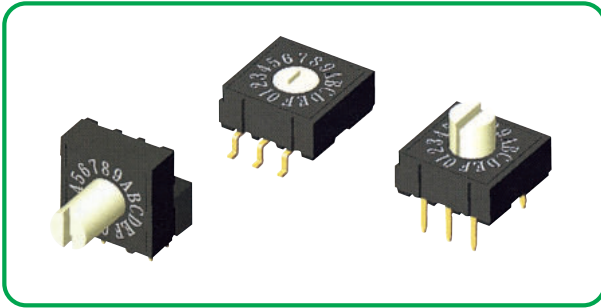

HOW TO ORDER

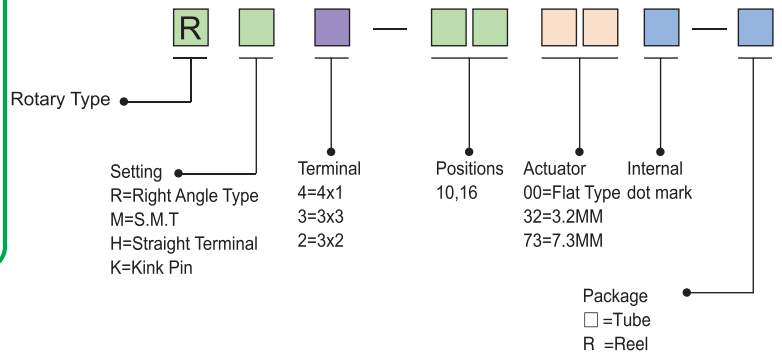

Specification

Items		Standard	Package
Environmental	Operation Temperature Range	-25°C to +80°C	
	Storage Temperature Range	-40°C to +85°C	Tape and Reel:
Electrical performance	Electrical Life	20,000 steps	750 pcs/reel (recessed actuator)
	Non-Switching Rating	100mA,50VDC	500 pcs/reel (3.2mm actuator)
	Switching Rating	25mA,24VDC	250 pcs/reel (7.3mm actuator)
Mechanical performance	Operating force	200gf-cm max	

Diagram

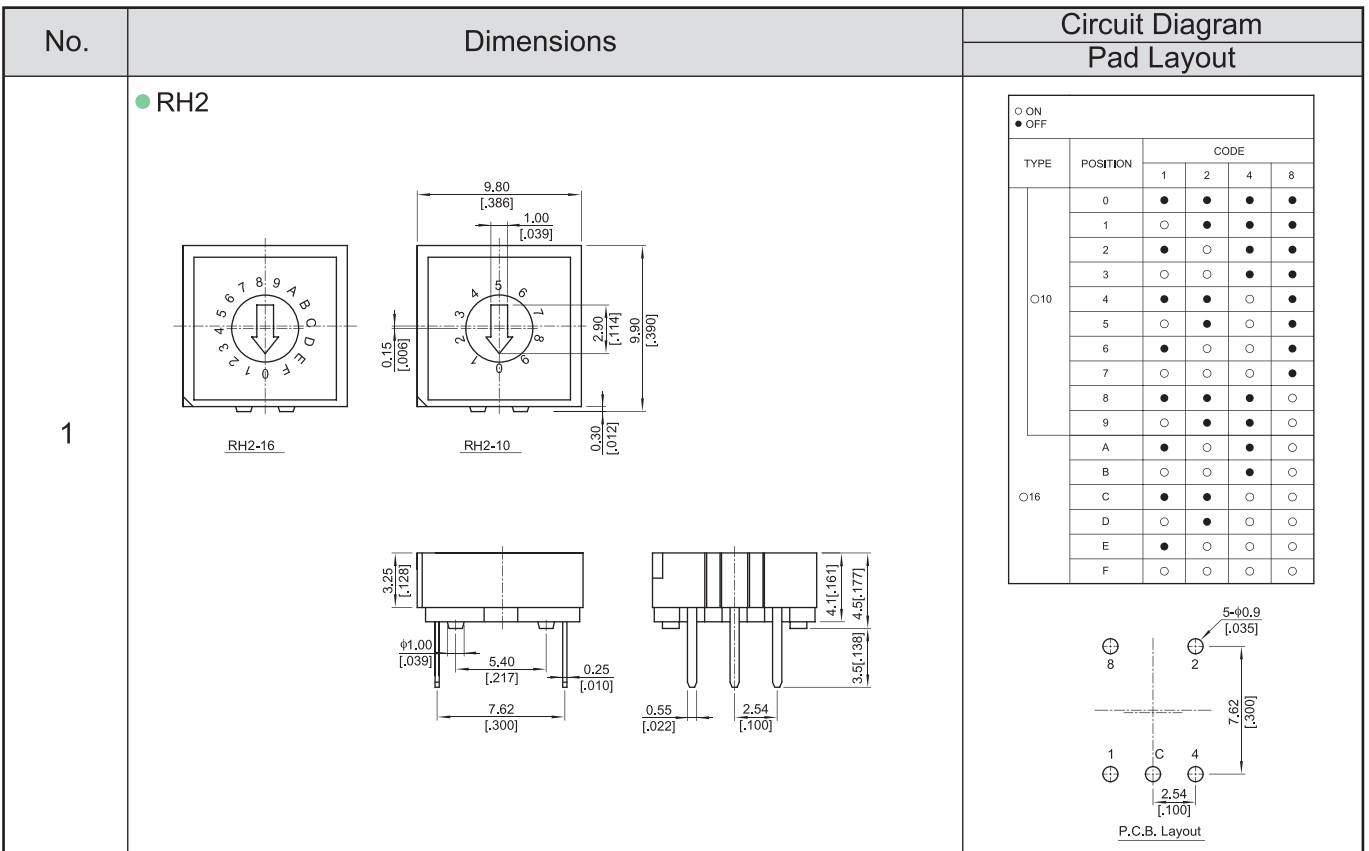

RS SERIES

10x10mm Rotary Type



Diagram

No.	Dimensions	Circuit Diagram Pad Layout																																																																																												
2	<p>● RM3</p>	<table border="1"> <thead> <tr> <th rowspan="2">TYPE</th> <th rowspan="2">POSITION</th> <th colspan="4">CODE</th> </tr> <tr> <th>1</th> <th>2</th> <th>4</th> <th>8</th> </tr> </thead> <tbody> <tr><td rowspan="10">O10</td><td>0</td><td>●</td><td>●</td><td>●</td><td>●</td></tr> <tr><td>1</td><td>○</td><td>○</td><td>○</td><td>○</td></tr> <tr><td>2</td><td>●</td><td>○</td><td>○</td><td>○</td></tr> <tr><td>3</td><td>○</td><td>○</td><td>○</td><td>○</td></tr> <tr><td>4</td><td>●</td><td>●</td><td>○</td><td>○</td></tr> <tr><td>5</td><td>○</td><td>○</td><td>○</td><td>○</td></tr> <tr><td>6</td><td>●</td><td>○</td><td>○</td><td>○</td></tr> <tr><td>7</td><td>○</td><td>○</td><td>○</td><td>○</td></tr> <tr><td>8</td><td>●</td><td>○</td><td>○</td><td>○</td></tr> <tr><td>9</td><td>○</td><td>○</td><td>○</td><td>○</td></tr> <tr><td rowspan="6">O16</td><td>A</td><td>●</td><td>○</td><td>○</td><td>○</td></tr> <tr><td>B</td><td>○</td><td>○</td><td>○</td><td>○</td></tr> <tr><td>C</td><td>●</td><td>○</td><td>○</td><td>○</td></tr> <tr><td>D</td><td>○</td><td>○</td><td>○</td><td>○</td></tr> <tr><td>E</td><td>○</td><td>○</td><td>○</td><td>○</td></tr> <tr><td>F</td><td>○</td><td>○</td><td>○</td><td>○</td></tr> </tbody> </table> <p>P.C.B. Layout</p>	TYPE	POSITION	CODE				1	2	4	8	O10	0	●	●	●	●	1	○	○	○	○	2	●	○	○	○	3	○	○	○	○	4	●	●	○	○	5	○	○	○	○	6	●	○	○	○	7	○	○	○	○	8	●	○	○	○	9	○	○	○	○	O16	A	●	○	○	○	B	○	○	○	○	C	●	○	○	○	D	○	○	○	○	E	○	○	○	○	F	○	○	○	○
TYPE	POSITION	CODE																																																																																												
		1	2	4	8																																																																																									
O10	0	●	●	●	●																																																																																									
	1	○	○	○	○																																																																																									
	2	●	○	○	○																																																																																									
	3	○	○	○	○																																																																																									
	4	●	●	○	○																																																																																									
	5	○	○	○	○																																																																																									
	6	●	○	○	○																																																																																									
	7	○	○	○	○																																																																																									
	8	●	○	○	○																																																																																									
	9	○	○	○	○																																																																																									
O16	A	●	○	○	○																																																																																									
	B	○	○	○	○																																																																																									
	C	●	○	○	○																																																																																									
	D	○	○	○	○																																																																																									
	E	○	○	○	○																																																																																									
	F	○	○	○	○																																																																																									
3	<p>● RR4</p>	<table border="1"> <thead> <tr> <th rowspan="2">TYPE</th> <th rowspan="2">POSITION</th> <th colspan="4">CODE</th> </tr> <tr> <th>1</th> <th>2</th> <th>4</th> <th>8</th> </tr> </thead> <tbody> <tr><td rowspan="10">O10</td><td>0</td><td>●</td><td>●</td><td>●</td><td>●</td></tr> <tr><td>1</td><td>○</td><td>○</td><td>○</td><td>○</td></tr> <tr><td>2</td><td>●</td><td>○</td><td>○</td><td>○</td></tr> <tr><td>3</td><td>○</td><td>○</td><td>○</td><td>○</td></tr> <tr><td>4</td><td>●</td><td>●</td><td>○</td><td>○</td></tr> <tr><td>5</td><td>○</td><td>○</td><td>○</td><td>○</td></tr> <tr><td>6</td><td>●</td><td>○</td><td>○</td><td>○</td></tr> <tr><td>7</td><td>○</td><td>○</td><td>○</td><td>○</td></tr> <tr><td>8</td><td>●</td><td>○</td><td>○</td><td>○</td></tr> <tr><td>9</td><td>○</td><td>○</td><td>○</td><td>○</td></tr> <tr><td rowspan="6">O16</td><td>A</td><td>●</td><td>○</td><td>○</td><td>○</td></tr> <tr><td>B</td><td>○</td><td>○</td><td>○</td><td>○</td></tr> <tr><td>C</td><td>●</td><td>○</td><td>○</td><td>○</td></tr> <tr><td>D</td><td>○</td><td>○</td><td>○</td><td>○</td></tr> <tr><td>E</td><td>○</td><td>○</td><td>○</td><td>○</td></tr> <tr><td>F</td><td>○</td><td>○</td><td>○</td><td>○</td></tr> </tbody> </table> <p>P.C.B. Layout</p>	TYPE	POSITION	CODE				1	2	4	8	O10	0	●	●	●	●	1	○	○	○	○	2	●	○	○	○	3	○	○	○	○	4	●	●	○	○	5	○	○	○	○	6	●	○	○	○	7	○	○	○	○	8	●	○	○	○	9	○	○	○	○	O16	A	●	○	○	○	B	○	○	○	○	C	●	○	○	○	D	○	○	○	○	E	○	○	○	○	F	○	○	○	○
TYPE	POSITION	CODE																																																																																												
		1	2	4	8																																																																																									
O10	0	●	●	●	●																																																																																									
	1	○	○	○	○																																																																																									
	2	●	○	○	○																																																																																									
	3	○	○	○	○																																																																																									
	4	●	●	○	○																																																																																									
	5	○	○	○	○																																																																																									
	6	●	○	○	○																																																																																									
	7	○	○	○	○																																																																																									
	8	●	○	○	○																																																																																									
	9	○	○	○	○																																																																																									
O16	A	●	○	○	○																																																																																									
	B	○	○	○	○																																																																																									
	C	●	○	○	○																																																																																									
	D	○	○	○	○																																																																																									
	E	○	○	○	○																																																																																									
	F	○	○	○	○																																																																																									
4	<p>● RK2</p>	<table border="1"> <thead> <tr> <th rowspan="2">TYPE</th> <th rowspan="2">POSITION</th> <th colspan="4">CODE</th> </tr> <tr> <th>1</th> <th>2</th> <th>4</th> <th>8</th> </tr> </thead> <tbody> <tr><td rowspan="10">O10</td><td>0</td><td>●</td><td>●</td><td>●</td><td>●</td></tr> <tr><td>1</td><td>○</td><td>○</td><td>○</td><td>○</td></tr> <tr><td>2</td><td>●</td><td>○</td><td>○</td><td>○</td></tr> <tr><td>3</td><td>○</td><td>○</td><td>○</td><td>○</td></tr> <tr><td>4</td><td>●</td><td>●</td><td>○</td><td>○</td></tr> <tr><td>5</td><td>○</td><td>○</td><td>○</td><td>○</td></tr> <tr><td>6</td><td>●</td><td>○</td><td>○</td><td>○</td></tr> <tr><td>7</td><td>○</td><td>○</td><td>○</td><td>○</td></tr> <tr><td>8</td><td>●</td><td>○</td><td>○</td><td>○</td></tr> <tr><td>9</td><td>○</td><td>○</td><td>○</td><td>○</td></tr> <tr><td rowspan="6">O16</td><td>A</td><td>●</td><td>○</td><td>○</td><td>○</td></tr> <tr><td>B</td><td>○</td><td>○</td><td>○</td><td>○</td></tr> <tr><td>C</td><td>●</td><td>○</td><td>○</td><td>○</td></tr> <tr><td>D</td><td>○</td><td>○</td><td>○</td><td>○</td></tr> <tr><td>E</td><td>○</td><td>○</td><td>○</td><td>○</td></tr> <tr><td>F</td><td>○</td><td>○</td><td>○</td><td>○</td></tr> </tbody> </table> <p>P.C.B. Layout</p>	TYPE	POSITION	CODE				1	2	4	8	O10	0	●	●	●	●	1	○	○	○	○	2	●	○	○	○	3	○	○	○	○	4	●	●	○	○	5	○	○	○	○	6	●	○	○	○	7	○	○	○	○	8	●	○	○	○	9	○	○	○	○	O16	A	●	○	○	○	B	○	○	○	○	C	●	○	○	○	D	○	○	○	○	E	○	○	○	○	F	○	○	○	○
TYPE	POSITION	CODE																																																																																												
		1	2	4	8																																																																																									
O10	0	●	●	●	●																																																																																									
	1	○	○	○	○																																																																																									
	2	●	○	○	○																																																																																									
	3	○	○	○	○																																																																																									
	4	●	●	○	○																																																																																									
	5	○	○	○	○																																																																																									
	6	●	○	○	○																																																																																									
	7	○	○	○	○																																																																																									
	8	●	○	○	○																																																																																									
	9	○	○	○	○																																																																																									
O16	A	●	○	○	○																																																																																									
	B	○	○	○	○																																																																																									
	C	●	○	○	○																																																																																									
	D	○	○	○	○																																																																																									
	E	○	○	○	○																																																																																									
	F	○	○	○	○																																																																																									

RS SERIES

7x7mm Rotary Type

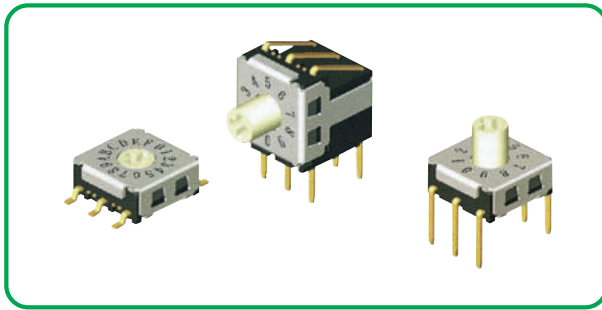

HOW TO ORDER

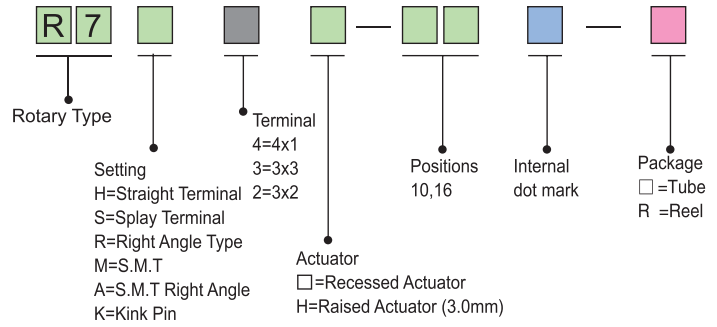

Specification

Items		Standard	Package
Environmental	Operation Temperature Range	-30°C to +80°C	R7H,R7M:63pcs/tube
	Storage Temperature Range	-40°C to +85°C	R7R:60pcs/tube
Electrical performance	Electrical Life	10,000 steps	R7M*:1450pcs/reel
	Switching Rating	25mA,24VDC	R7M*H:850pcs/reel
Mechanical performance	Operating force	200gf-cm max	R7A:750pcs/reel
			R7A4H:750pcs/reel

Diagram

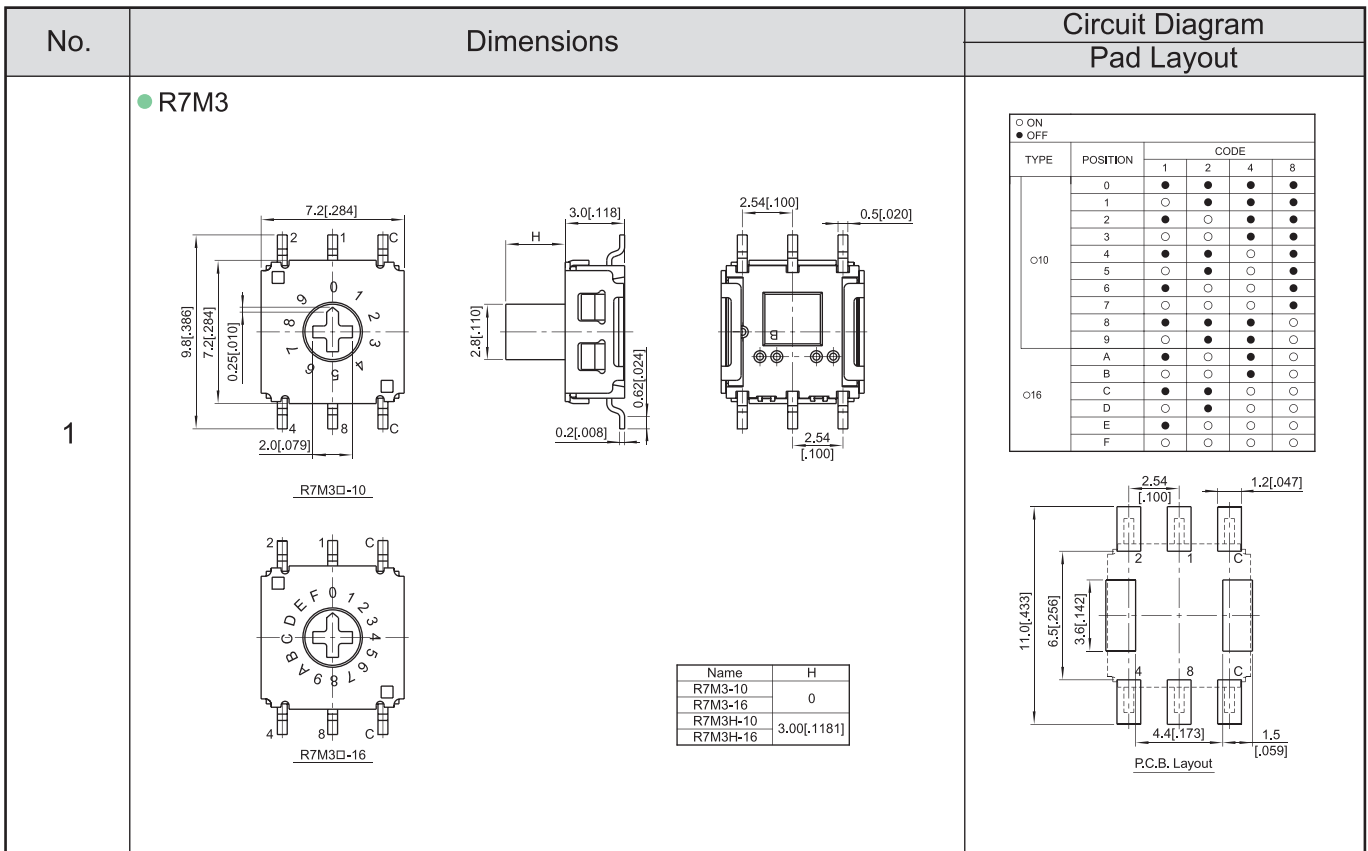

ROTARY CODED SWITCH

RS SERIES

7x7mm Rotary Type



Diagram

No.	Dimensions	Circuit Diagram Pad Layout						
2	<p>● R7H3</p> <table border="1"> <thead> <tr> <th>Name</th> <th>H</th> </tr> </thead> <tbody> <tr> <td>R7H3-10</td> <td>0</td> </tr> <tr> <td>R7H3-16</td> <td>3.00[.1181]</td> </tr> </tbody> </table>	Name	H	R7H3-10	0	R7H3-16	3.00[.1181]	
Name	H							
R7H3-10	0							
R7H3-16	3.00[.1181]							
3	<p>● R7A4</p> <table border="1"> <thead> <tr> <th>Name</th> <th>H</th> </tr> </thead> <tbody> <tr> <td>R7A4-10</td> <td>0</td> </tr> <tr> <td>R7A4-16</td> <td>3.00[.1181]</td> </tr> </tbody> </table>	Name	H	R7A4-10	0	R7A4-16	3.00[.1181]	
Name	H							
R7A4-10	0							
R7A4-16	3.00[.1181]							
4	<p>● R7R4</p> <table border="1"> <thead> <tr> <th>Name</th> <th>H</th> </tr> </thead> <tbody> <tr> <td>R7R4-10</td> <td>0</td> </tr> <tr> <td>R7R4-16</td> <td>3.00[.1181]</td> </tr> </tbody> </table>	Name	H	R7R4-10	0	R7R4-16	3.00[.1181]	
Name	H							
R7R4-10	0							
R7R4-16	3.00[.1181]							

06

DIP SWITCH SERIES

Features:

- Smaller size makes better heat convection during PC board wave soldering.
- Top tape sealed to withstand wave soldering, board washing.
- All plastics are UL 94V-0 grade fire retardant.
- Gold plated contact to ensure low contact resistance and long mechanical life.

Applications:

- Hand-held electronic devices, such as PDA, MP3, radios.
- Portable computer and electronic devices, such as notebook, computers.
- Instrumentation and industrial control products, such as CDROM, coin changers.

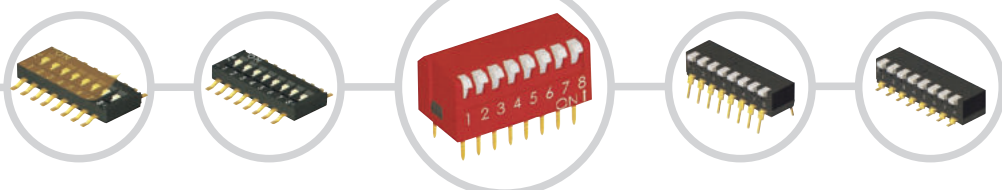

SMT SERIES

1.6mm Half Pitch SMT Type

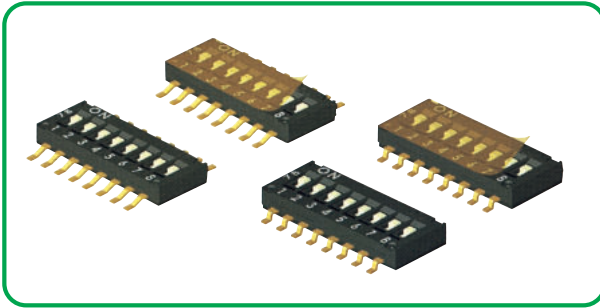

HOW TO ORDER

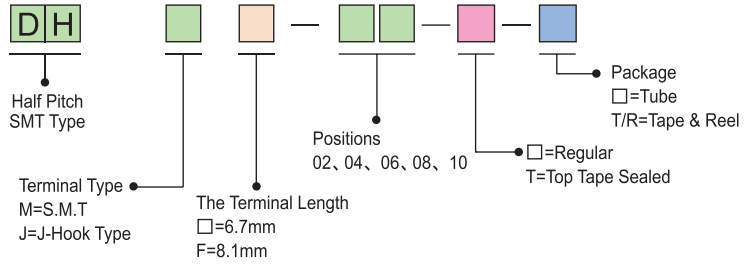

Precaution: For quality assurance, please operate actuators carefully refer specification.

Specification

Items		Standard	Package
Environmental	Operation Temperature Range	-40°C to +85°C	
	Storage Temperature Range	-40°C to +85°C	
Electrical performance	Electrical Life	1000 operation cycles	
	Non-Switching Rating	100mA,50VDC	
	Switching Rating	25mA,24VDC	
Mechanical performance	Operating force	500gf	
	Stroke	0.6mm	

Diagram

No.	Dimensions	Circuit Diagram Pad Layout																		
1	<p>● DHMF</p>	<table border="1"> <thead> <tr> <th>PROD.NO.</th> <th>NO.OF.POS.</th> <th>DM.A</th> </tr> </thead> <tbody> <tr><td>DHMF-10</td><td>10</td><td>13.93[.548]</td></tr> <tr><td>DHMF-08</td><td>08</td><td>11.39[.448]</td></tr> <tr><td>DHMF-06</td><td>06</td><td>8.85[.348]</td></tr> <tr><td>DHMF-04</td><td>04</td><td>6.31[.248]</td></tr> <tr><td>DHMF-02</td><td>02</td><td>3.77[.148]</td></tr> </tbody> </table> <p>P.C.B Layout</p>	PROD.NO.	NO.OF.POS.	DM.A	DHMF-10	10	13.93[.548]	DHMF-08	08	11.39[.448]	DHMF-06	06	8.85[.348]	DHMF-04	04	6.31[.248]	DHMF-02	02	3.77[.148]
PROD.NO.	NO.OF.POS.	DM.A																		
DHMF-10	10	13.93[.548]																		
DHMF-08	08	11.39[.448]																		
DHMF-06	06	8.85[.348]																		
DHMF-04	04	6.31[.248]																		
DHMF-02	02	3.77[.148]																		
2	<p>● DHM</p>	<table border="1"> <thead> <tr> <th>PROD.NO.</th> <th>NO.OF.POS.</th> <th>DM.A</th> </tr> </thead> <tbody> <tr><td>DHM-10</td><td>10</td><td>13.93[.548]</td></tr> <tr><td>DHM-08</td><td>08</td><td>11.39[.448]</td></tr> <tr><td>DHM-06</td><td>06</td><td>8.85[.348]</td></tr> <tr><td>DHM-04</td><td>04</td><td>6.31[.248]</td></tr> <tr><td>DHM-02</td><td>02</td><td>3.77[.148]</td></tr> </tbody> </table> <p>P.C.B Layout</p>	PROD.NO.	NO.OF.POS.	DM.A	DHM-10	10	13.93[.548]	DHM-08	08	11.39[.448]	DHM-06	06	8.85[.348]	DHM-04	04	6.31[.248]	DHM-02	02	3.77[.148]
PROD.NO.	NO.OF.POS.	DM.A																		
DHM-10	10	13.93[.548]																		
DHM-08	08	11.39[.448]																		
DHM-06	06	8.85[.348]																		
DHM-04	04	6.31[.248]																		
DHM-02	02	3.77[.148]																		

DIP SERIES

End-Stackable Type

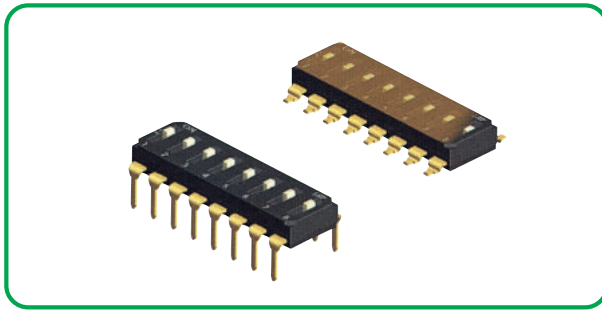

HOW TO ORDER

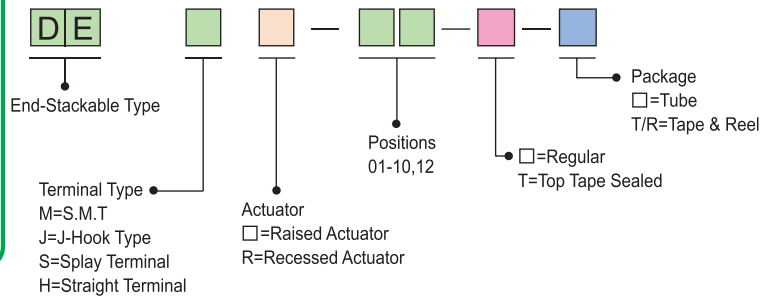

Specification

Items		Standard	Package
Environmental	Operation Temperature Range	-20°C to +85°C	DEM(R)/DEH(R)/DES(R)-01:194pcs/tube DEM(R)/DEH(R)/DES(R)-02:95pcs/tube DEM(R)/DEH(R)/DES(R)-03:63pcs/tube DEM(R)/DEH(R)/DES(R)/DEJ(R)-04:47pcs/tube DEM(R)/DEH(R)/DES(R)-05:38pcs/tube DEM(R)/DEH(R)/DES(R)-06:31pcs/tube DEM(R)/DEH(R)/DES(R)-07:27pcs/tube DEM(R)/DEH(R)/DES(R)/DEJ(R)-08:23pcs/tube DEM(R)/DEH(R)/DES(R)-09:21pcs/tube DEM(R)/DEH(R)/DES(R)/DEJ(R)-10:19pcs/tube DEM(R)/DEH(R)/DES(R)-12:15pcs/tube DEM(R)-01~10, 12:900 pcs/reel
	Storage Temperature Range	-40°C to +85°C	
Electrical performance	Electrical Life	2000 cycles	
	Switching Rating	25mA, 24VDC	
Mechanical performance	Operating force	1,000gf max.	
	Stroke	1.0mm	

Diagram

No.	Dimensions	Circuit Diagram				
		Pad Layout				
1	● DEM 	DEM-12 DEMR-12	12	30.38[.196]	27.94[1.100]	
		DEM-10 DEMR-10	10	25.3[.996]	22.86[.900]	
		DEM-09 DEMR-09	9	22.76[.896]	20.32[.800]	
		DEM-08 DEMR-08	8	20.22[.796]	17.78[.700]	
		DEM-07 DEMR-07	7	17.68[.696]	15.24[.600]	
		DEM-06 DEMR-06	6	15.14[.596]	12.70[.500]	
		DEM-05 DEMR-05	5	12.6[.496]	10.16[.400]	
		DEM-04 DEMR-04	4	10.06[.396]	7.62[.300]	
		DEM-03 DEMR-03	3	7.52[.296]	5.08[.200]	
		DEM-02 DEMR-02	2	4.98[.196]	2.54[.100]	
		DEM-01 DEMR-01	1	2.44[.096]	---	
		PROD.NO.	NO.OF POS.	DIM.A	DIM.B	
		SCHEMATIC(TYP.)				
		<p>(1, 2, 3, 4, 5, 6, 7, 8, 9, 10, 12, POS AVAIL)</p>				
		<p>P.C.B Layout</p>				

DIP SWITCH

DIP SERIES

End Stackable/SMT & Through Hole Type



Diagram

No.	Dimensions	Circuit Diagram																																																	
		Pad Layout																																																	
2	<p>● DEH</p>	<table border="1"> <tr><td>DEH-12</td><td>12</td><td>30.38[1.196]</td><td>27.94[1.100]</td></tr> <tr><td>DEH-10</td><td>10</td><td>25.3[.996]</td><td>22.86[.900]</td></tr> <tr><td>DEH-09</td><td>9</td><td>22.76[.896]</td><td>20.32[.800]</td></tr> <tr><td>DEH-08</td><td>8</td><td>20.22[.796]</td><td>17.78[.700]</td></tr> <tr><td>DEH-07</td><td>7</td><td>17.68[.696]</td><td>15.24[.600]</td></tr> <tr><td>DEH-06</td><td>6</td><td>15.14[.596]</td><td>12.70[.500]</td></tr> <tr><td>DEH-05</td><td>5</td><td>12.6[.496]</td><td>10.16[.400]</td></tr> <tr><td>DEH-04</td><td>4</td><td>10.06[.396]</td><td>7.62[.300]</td></tr> <tr><td>DEH-03</td><td>3</td><td>7.52[.296]</td><td>5.08[.200]</td></tr> <tr><td>DEH-02</td><td>2</td><td>4.98[.196]</td><td>2.54[.100]</td></tr> <tr><td>DEH-01</td><td>1</td><td>2.44[.096]</td><td>---</td></tr> <tr> <th>PROD.NO.</th> <th>N.O. OF POS.</th> <th>DIM.A</th> <th>DIM.B</th> </tr> </table>	DEH-12	12	30.38[1.196]	27.94[1.100]	DEH-10	10	25.3[.996]	22.86[.900]	DEH-09	9	22.76[.896]	20.32[.800]	DEH-08	8	20.22[.796]	17.78[.700]	DEH-07	7	17.68[.696]	15.24[.600]	DEH-06	6	15.14[.596]	12.70[.500]	DEH-05	5	12.6[.496]	10.16[.400]	DEH-04	4	10.06[.396]	7.62[.300]	DEH-03	3	7.52[.296]	5.08[.200]	DEH-02	2	4.98[.196]	2.54[.100]	DEH-01	1	2.44[.096]	---	PROD.NO.	N.O. OF POS.	DIM.A	DIM.B	<p>SCHEMATIC(TYP.)</p> <p>P.C.B Layout</p>
		DEH-12	12	30.38[1.196]	27.94[1.100]																																														
DEH-10	10	25.3[.996]	22.86[.900]																																																
DEH-09	9	22.76[.896]	20.32[.800]																																																
DEH-08	8	20.22[.796]	17.78[.700]																																																
DEH-07	7	17.68[.696]	15.24[.600]																																																
DEH-06	6	15.14[.596]	12.70[.500]																																																
DEH-05	5	12.6[.496]	10.16[.400]																																																
DEH-04	4	10.06[.396]	7.62[.300]																																																
DEH-03	3	7.52[.296]	5.08[.200]																																																
DEH-02	2	4.98[.196]	2.54[.100]																																																
DEH-01	1	2.44[.096]	---																																																
PROD.NO.	N.O. OF POS.	DIM.A	DIM.B																																																
3	<p>● DES</p>	<table border="1"> <tr><td>DES-12</td><td>12</td><td>30.38[1.196]</td><td>27.94[1.100]</td></tr> <tr><td>DES-10</td><td>10</td><td>25.3[.996]</td><td>22.86[.900]</td></tr> <tr><td>DES-09</td><td>9</td><td>22.76[.896]</td><td>20.32[.800]</td></tr> <tr><td>DES-08</td><td>8</td><td>20.22[.796]</td><td>17.78[.700]</td></tr> <tr><td>DES-07</td><td>7</td><td>17.68[.696]</td><td>15.24[.600]</td></tr> <tr><td>DES-06</td><td>6</td><td>15.14[.596]</td><td>12.70[.500]</td></tr> <tr><td>DES-05</td><td>5</td><td>12.6[.496]</td><td>10.16[.400]</td></tr> <tr><td>DES-04</td><td>4</td><td>10.06[.396]</td><td>7.62[.300]</td></tr> <tr><td>DES-03</td><td>3</td><td>7.52[.296]</td><td>5.08[.200]</td></tr> <tr><td>DES-02</td><td>2</td><td>4.98[.196]</td><td>2.54[.100]</td></tr> <tr><td>DES-01</td><td>1</td><td>2.44[.096]</td><td>---</td></tr> <tr> <th>PROD.NO.</th> <th>N.O. OF POS.</th> <th>DIM.A</th> <th>DIM.B</th> </tr> </table>	DES-12	12	30.38[1.196]	27.94[1.100]	DES-10	10	25.3[.996]	22.86[.900]	DES-09	9	22.76[.896]	20.32[.800]	DES-08	8	20.22[.796]	17.78[.700]	DES-07	7	17.68[.696]	15.24[.600]	DES-06	6	15.14[.596]	12.70[.500]	DES-05	5	12.6[.496]	10.16[.400]	DES-04	4	10.06[.396]	7.62[.300]	DES-03	3	7.52[.296]	5.08[.200]	DES-02	2	4.98[.196]	2.54[.100]	DES-01	1	2.44[.096]	---	PROD.NO.	N.O. OF POS.	DIM.A	DIM.B	<p>SCHEMATIC(TYP.)</p> <p>P.C.B Layout</p>
		DES-12	12	30.38[1.196]	27.94[1.100]																																														
DES-10	10	25.3[.996]	22.86[.900]																																																
DES-09	9	22.76[.896]	20.32[.800]																																																
DES-08	8	20.22[.796]	17.78[.700]																																																
DES-07	7	17.68[.696]	15.24[.600]																																																
DES-06	6	15.14[.596]	12.70[.500]																																																
DES-05	5	12.6[.496]	10.16[.400]																																																
DES-04	4	10.06[.396]	7.62[.300]																																																
DES-03	3	7.52[.296]	5.08[.200]																																																
DES-02	2	4.98[.196]	2.54[.100]																																																
DES-01	1	2.44[.096]	---																																																
PROD.NO.	N.O. OF POS.	DIM.A	DIM.B																																																
4	<p>● DEJ</p>	<table border="1"> <tr><td>DEJ-10</td><td>10</td><td>25.3[.996]</td><td>22.86[.900]</td></tr> <tr><td>DEJ-08</td><td>8</td><td>20.22[.796]</td><td>17.78[.700]</td></tr> <tr><td>DEJ-04</td><td>4</td><td>10.06[.396]</td><td>7.62[.300]</td></tr> <tr> <th>PROD.NO.</th> <th>N.O. OF POS.</th> <th>DIM.A</th> <th>DIM.B</th> </tr> </table>	DEJ-10	10	25.3[.996]	22.86[.900]	DEJ-08	8	20.22[.796]	17.78[.700]	DEJ-04	4	10.06[.396]	7.62[.300]	PROD.NO.	N.O. OF POS.	DIM.A	DIM.B	<p>SCHEMATIC(TYP.)</p> <p>P.C.B Layout</p>																																
		DEJ-10	10	25.3[.996]	22.86[.900]																																														
DEJ-08	8	20.22[.796]	17.78[.700]																																																
DEJ-04	4	10.06[.396]	7.62[.300]																																																
PROD.NO.	N.O. OF POS.	DIM.A	DIM.B																																																

DIP SWITCH

DIP SERIES

Auto Inserting IC Type

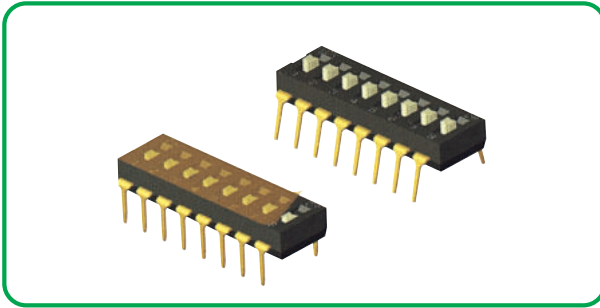

HOW TO ORDER

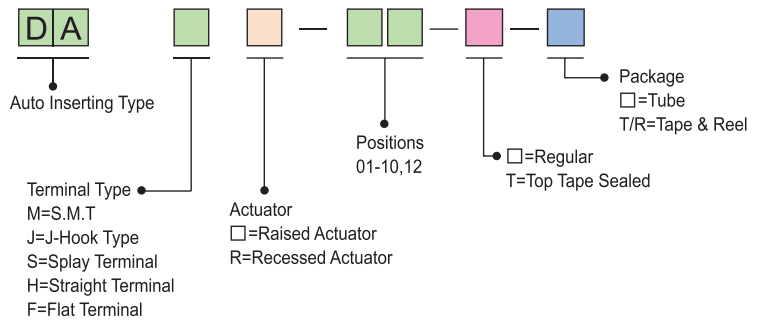

Specification

Items		Standard	Package
Environmental	Operation Temperature Range	-20°C to +85°C	
	Storage Temperature Range	-40°C to +85°C	
Electrical performance	Electrical Life	2,000 operations	
	Non-Switching Rating	100mA,50VDC	
	Switching Rating	25mA,24VDC	
Mechanical performance	Mechanical Life	2,000 operations	
	Operating force	1,000gf max.	
	Stroke	1.0mm	

Diagram

No.	Dimensions	Circuit Diagram			
		Pad Layout			
1	<p>● DAH(S)</p> <p>Splay Terminal</p> <p>Straight Terminal</p>	DAH-12 DAHR-12	12	31.42[1.237]	27.94[1.100]
		DAH-10 DAHR-10	10	26.34[1.037]	22.86[.900]
		DAH-09 DAHR-09	9	23.80[.937]	20.32[.800]
		DAH-08 DAHR-08	8	21.26[.837]	17.78[.700]
		DAH-07 DAHR-07	7	18.72[.737]	15.24[.600]
		DAH-06 DAHR-06	6	16.18[.637]	12.70[.500]
		DAH-05 DAHR-05	5	13.64[.537]	10.16[.400]
		DAH-04 DAHR-04	4	11.10[.437]	7.62[.300]
		DAH-03 DAHR-03	3	8.56[.337]	5.08[.200]
		DAH-02 DAHR-02	2	6.02[.237]	2.54[.100]
DAH-01 DAHR-01	1	3.48[.137]	---		
<p>PROD.NO. NO.OF POS. DIM.A DIM.B</p> <p>SCHEMATIC(TYP.)</p> <p>(1,2,3,4,5,6,7,8,9,10,12, POS AVAIL)</p> <p>P.C.B. Layout</p>					

DIP SWITCH

DIP SERIES

Surface Mount IC Type

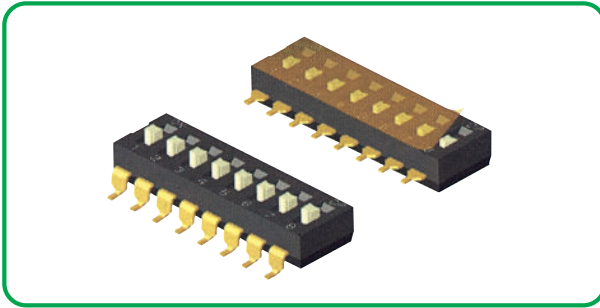

HOW TO ORDER

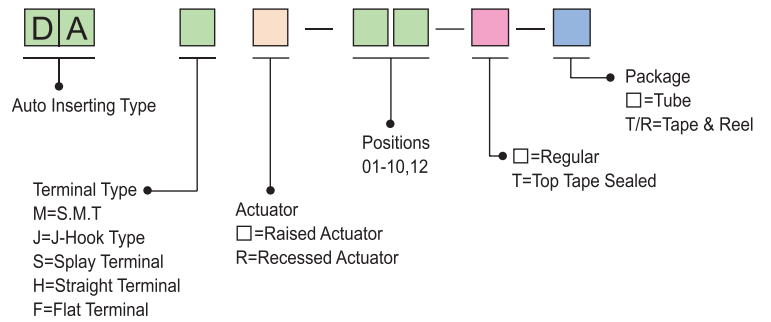

Specification

Items		Standard	Package
Environmental	Operation Temperature Range	-20°C to +85°C	DAM(R)-01(-T):130pcs/tube DAM(R)-02(-T):76pcs/tube DAM(R)-03(-T):55pcs/tube DAM(R)-04(-T):42pcs/tube DAM(R)-05(-T):35pcs/tube DAM(R)-06(-T):28pcs/tube DAM(R)-07(-T):25pcs/tube DAM(R)-08(-T):22pcs/tube DAM(R)-09(-T):20pcs/tube DAM(R)-10(-T):18pcs/tube DAM(R)-12(-T):15pcs/tube DAM(R)-01-T-T/R:800pcs/reel DAMR-02-T-T/R~DMR-12-T-TR:900pcs/reel DAM-(01)(05)(07)(10)-T/R:800pcs/reel DAM-(02)(03)(04)(06)(08)(12)-T/R:700pcs/reel DJR-(02)(03)(04)(08)(09)(10)-T/R:1000pcs/reel
	Storage Temperature Range	-40°C to +85°C	
Electrical performance	Electrical Life	2,000 operations	
	Non-Switching Rating	100mA,50VDC	
	Switching Rating	25mA,24VDC	
Mechanical performance	Mechanical Life	2,000 operations	
	Operating force	1,000gf max.	
	Stroke	1.0mm	

Diagram

No.	Dimensions	Circuit Diagram Pad Layout				
		PROD.NO.	NO.OF POS.	DIM.A	DIM.B	
1	<p>DAM</p>	DAM-12 DAMR-12	12	31.42[1.237]	27.94[1.100]	
		DAM-10 DAMR-10	10	26.34[1.037]	22.86[.900]	
		DAM-09 DAMR-09	9	23.80[.937]	20.32[.800]	
		DAM-08 DAMR-08	8	21.26[.837]	17.78[.700]	
		DAM-07 DAMR-07	7	18.72[.737]	15.24[.600]	
		DAM-06 DAMR-06	6	16.18[.637]	12.70[.500]	
		DAM-05 DAMR-05	5	13.64[.537]	10.16[.400]	
		DAM-04 DAMR-04	4	11.10[.437]	7.62[.300]	
		DAM-03 DAMR-03	3	8.56[.337]	5.08[.200]	
		DAM-02 DAMR-02	2	6.02[.237]	2.54[.100]	
		DAM-01 DAMR-01	1	3.48[.137]	---	
		SCHEMATIC(TYP.)		<p>(1,2,3,4,5,6,7,8,9,10,12, POS AVAIL)</p>		
		P.C.B. Layout				

DIP SWITCH

DIP SERIES

Auto Inserting Type



Diagram

No.	Dimensions	Circuit Diagram																																																																																																																																																																																					
		Pad Layout																																																																																																																																																																																					
2	<p>● DAJ</p>	<table border="1"> <tr><td>DAJ-12</td><td>12</td><td>31.42[1.237]</td><td>27.94[1.100]</td></tr> <tr><td>DAJR-12</td><td>12</td><td>31.42[1.237]</td><td>27.94[1.100]</td></tr> <tr><td>DAJ-10</td><td>10</td><td>26.34[1.037]</td><td>22.86[.900]</td></tr> <tr><td>DAJR-10</td><td>10</td><td>26.34[1.037]</td><td>22.86[.900]</td></tr> <tr><td>DAJ-09</td><td>9</td><td>23.80[.937]</td><td>20.32[.800]</td></tr> <tr><td>DAJR-09</td><td>9</td><td>23.80[.937]</td><td>20.32[.800]</td></tr> <tr><td>DAJ-08</td><td>8</td><td>21.26[.837]</td><td>17.78[.700]</td></tr> <tr><td>DAJR-08</td><td>8</td><td>21.26[.837]</td><td>17.78[.700]</td></tr> <tr><td>DAJ-07</td><td>7</td><td>18.72[.737]</td><td>15.24[.600]</td></tr> <tr><td>DAJR-07</td><td>7</td><td>18.72[.737]</td><td>15.24[.600]</td></tr> <tr><td>DAJ-06</td><td>6</td><td>16.18[.637]</td><td>12.70[.500]</td></tr> <tr><td>DAJR-06</td><td>6</td><td>16.18[.637]</td><td>12.70[.500]</td></tr> <tr><td>DAJ-05</td><td>5</td><td>13.64[.537]</td><td>10.16[.400]</td></tr> <tr><td>DAJR-05</td><td>5</td><td>13.64[.537]</td><td>10.16[.400]</td></tr> <tr><td>DAJ-04</td><td>4</td><td>11.10[.437]</td><td>7.62[.300]</td></tr> <tr><td>DAJR-04</td><td>4</td><td>11.10[.437]</td><td>7.62[.300]</td></tr> <tr><td>DAJ-03</td><td>3</td><td>8.56[.337]</td><td>5.08[.200]</td></tr> <tr><td>DAJR-03</td><td>3</td><td>8.56[.337]</td><td>5.08[.200]</td></tr> <tr><td>DAJ-02</td><td>2</td><td>6.02[.237]</td><td>2.54[.100]</td></tr> <tr><td>DAJR-02</td><td>2</td><td>6.02[.237]</td><td>2.54[.100]</td></tr> <tr><td>DAJ-01</td><td>1</td><td>---</td><td>---</td></tr> <tr><td>DAJR-01</td><td>1</td><td>---</td><td>---</td></tr> </table>	DAJ-12	12	31.42[1.237]	27.94[1.100]	DAJR-12	12	31.42[1.237]	27.94[1.100]	DAJ-10	10	26.34[1.037]	22.86[.900]	DAJR-10	10	26.34[1.037]	22.86[.900]	DAJ-09	9	23.80[.937]	20.32[.800]	DAJR-09	9	23.80[.937]	20.32[.800]	DAJ-08	8	21.26[.837]	17.78[.700]	DAJR-08	8	21.26[.837]	17.78[.700]	DAJ-07	7	18.72[.737]	15.24[.600]	DAJR-07	7	18.72[.737]	15.24[.600]	DAJ-06	6	16.18[.637]	12.70[.500]	DAJR-06	6	16.18[.637]	12.70[.500]	DAJ-05	5	13.64[.537]	10.16[.400]	DAJR-05	5	13.64[.537]	10.16[.400]	DAJ-04	4	11.10[.437]	7.62[.300]	DAJR-04	4	11.10[.437]	7.62[.300]	DAJ-03	3	8.56[.337]	5.08[.200]	DAJR-03	3	8.56[.337]	5.08[.200]	DAJ-02	2	6.02[.237]	2.54[.100]	DAJR-02	2	6.02[.237]	2.54[.100]	DAJ-01	1	---	---	DAJR-01	1	---	---	<table border="1"> <tr><th>PROD.NO.</th><th>NO.OF POS.</th><th>DIM.A</th><th>DIM.B</th></tr> <tr><td>DAJ-12</td><td>12</td><td>31.42[1.237]</td><td>27.94[1.100]</td></tr> <tr><td>DAJR-12</td><td>12</td><td>31.42[1.237]</td><td>27.94[1.100]</td></tr> <tr><td>DAJ-10</td><td>10</td><td>26.34[1.037]</td><td>22.86[.900]</td></tr> <tr><td>DAJR-10</td><td>10</td><td>26.34[1.037]</td><td>22.86[.900]</td></tr> <tr><td>DAJ-09</td><td>9</td><td>23.80[.937]</td><td>20.32[.800]</td></tr> <tr><td>DAJR-09</td><td>9</td><td>23.80[.937]</td><td>20.32[.800]</td></tr> <tr><td>DAJ-08</td><td>8</td><td>21.26[.837]</td><td>17.78[.700]</td></tr> <tr><td>DAJR-08</td><td>8</td><td>21.26[.837]</td><td>17.78[.700]</td></tr> <tr><td>DAJ-07</td><td>7</td><td>18.72[.737]</td><td>15.24[.600]</td></tr> <tr><td>DAJR-07</td><td>7</td><td>18.72[.737]</td><td>15.24[.600]</td></tr> <tr><td>DAJ-06</td><td>6</td><td>16.18[.637]</td><td>12.70[.500]</td></tr> <tr><td>DAJR-06</td><td>6</td><td>16.18[.637]</td><td>12.70[.500]</td></tr> <tr><td>DAJ-05</td><td>5</td><td>13.64[.537]</td><td>10.16[.400]</td></tr> <tr><td>DAJR-05</td><td>5</td><td>13.64[.537]</td><td>10.16[.400]</td></tr> <tr><td>DAJ-04</td><td>4</td><td>11.10[.437]</td><td>7.62[.300]</td></tr> <tr><td>DAJR-04</td><td>4</td><td>11.10[.437]</td><td>7.62[.300]</td></tr> <tr><td>DAJ-03</td><td>3</td><td>8.56[.337]</td><td>5.08[.200]</td></tr> <tr><td>DAJR-03</td><td>3</td><td>8.56[.337]</td><td>5.08[.200]</td></tr> <tr><td>DAJ-02</td><td>2</td><td>6.02[.237]</td><td>2.54[.100]</td></tr> <tr><td>DAJR-02</td><td>2</td><td>6.02[.237]</td><td>2.54[.100]</td></tr> <tr><td>DAJ-01</td><td>1</td><td>---</td><td>---</td></tr> <tr><td>DAJR-01</td><td>1</td><td>---</td><td>---</td></tr> </table> <p>SCHEMATIC(TYP.)</p> <p>(1,2,3,4,5,6,7,8,9,10,12, POS AVAIL)</p> <p>P.C.B. Layout</p>	PROD.NO.	NO.OF POS.	DIM.A	DIM.B	DAJ-12	12	31.42[1.237]	27.94[1.100]	DAJR-12	12	31.42[1.237]	27.94[1.100]	DAJ-10	10	26.34[1.037]	22.86[.900]	DAJR-10	10	26.34[1.037]	22.86[.900]	DAJ-09	9	23.80[.937]	20.32[.800]	DAJR-09	9	23.80[.937]	20.32[.800]	DAJ-08	8	21.26[.837]	17.78[.700]	DAJR-08	8	21.26[.837]	17.78[.700]	DAJ-07	7	18.72[.737]	15.24[.600]	DAJR-07	7	18.72[.737]	15.24[.600]	DAJ-06	6	16.18[.637]	12.70[.500]	DAJR-06	6	16.18[.637]	12.70[.500]	DAJ-05	5	13.64[.537]	10.16[.400]	DAJR-05	5	13.64[.537]	10.16[.400]	DAJ-04	4	11.10[.437]	7.62[.300]	DAJR-04	4	11.10[.437]	7.62[.300]	DAJ-03	3	8.56[.337]	5.08[.200]	DAJR-03	3	8.56[.337]	5.08[.200]	DAJ-02	2	6.02[.237]	2.54[.100]	DAJR-02	2	6.02[.237]	2.54[.100]	DAJ-01	1	---	---	DAJR-01	1	---	---
		DAJ-12	12	31.42[1.237]	27.94[1.100]																																																																																																																																																																																		
DAJR-12	12	31.42[1.237]	27.94[1.100]																																																																																																																																																																																				
DAJ-10	10	26.34[1.037]	22.86[.900]																																																																																																																																																																																				
DAJR-10	10	26.34[1.037]	22.86[.900]																																																																																																																																																																																				
DAJ-09	9	23.80[.937]	20.32[.800]																																																																																																																																																																																				
DAJR-09	9	23.80[.937]	20.32[.800]																																																																																																																																																																																				
DAJ-08	8	21.26[.837]	17.78[.700]																																																																																																																																																																																				
DAJR-08	8	21.26[.837]	17.78[.700]																																																																																																																																																																																				
DAJ-07	7	18.72[.737]	15.24[.600]																																																																																																																																																																																				
DAJR-07	7	18.72[.737]	15.24[.600]																																																																																																																																																																																				
DAJ-06	6	16.18[.637]	12.70[.500]																																																																																																																																																																																				
DAJR-06	6	16.18[.637]	12.70[.500]																																																																																																																																																																																				
DAJ-05	5	13.64[.537]	10.16[.400]																																																																																																																																																																																				
DAJR-05	5	13.64[.537]	10.16[.400]																																																																																																																																																																																				
DAJ-04	4	11.10[.437]	7.62[.300]																																																																																																																																																																																				
DAJR-04	4	11.10[.437]	7.62[.300]																																																																																																																																																																																				
DAJ-03	3	8.56[.337]	5.08[.200]																																																																																																																																																																																				
DAJR-03	3	8.56[.337]	5.08[.200]																																																																																																																																																																																				
DAJ-02	2	6.02[.237]	2.54[.100]																																																																																																																																																																																				
DAJR-02	2	6.02[.237]	2.54[.100]																																																																																																																																																																																				
DAJ-01	1	---	---																																																																																																																																																																																				
DAJR-01	1	---	---																																																																																																																																																																																				
PROD.NO.	NO.OF POS.	DIM.A	DIM.B																																																																																																																																																																																				
DAJ-12	12	31.42[1.237]	27.94[1.100]																																																																																																																																																																																				
DAJR-12	12	31.42[1.237]	27.94[1.100]																																																																																																																																																																																				
DAJ-10	10	26.34[1.037]	22.86[.900]																																																																																																																																																																																				
DAJR-10	10	26.34[1.037]	22.86[.900]																																																																																																																																																																																				
DAJ-09	9	23.80[.937]	20.32[.800]																																																																																																																																																																																				
DAJR-09	9	23.80[.937]	20.32[.800]																																																																																																																																																																																				
DAJ-08	8	21.26[.837]	17.78[.700]																																																																																																																																																																																				
DAJR-08	8	21.26[.837]	17.78[.700]																																																																																																																																																																																				
DAJ-07	7	18.72[.737]	15.24[.600]																																																																																																																																																																																				
DAJR-07	7	18.72[.737]	15.24[.600]																																																																																																																																																																																				
DAJ-06	6	16.18[.637]	12.70[.500]																																																																																																																																																																																				
DAJR-06	6	16.18[.637]	12.70[.500]																																																																																																																																																																																				
DAJ-05	5	13.64[.537]	10.16[.400]																																																																																																																																																																																				
DAJR-05	5	13.64[.537]	10.16[.400]																																																																																																																																																																																				
DAJ-04	4	11.10[.437]	7.62[.300]																																																																																																																																																																																				
DAJR-04	4	11.10[.437]	7.62[.300]																																																																																																																																																																																				
DAJ-03	3	8.56[.337]	5.08[.200]																																																																																																																																																																																				
DAJR-03	3	8.56[.337]	5.08[.200]																																																																																																																																																																																				
DAJ-02	2	6.02[.237]	2.54[.100]																																																																																																																																																																																				
DAJR-02	2	6.02[.237]	2.54[.100]																																																																																																																																																																																				
DAJ-01	1	---	---																																																																																																																																																																																				
DAJR-01	1	---	---																																																																																																																																																																																				
3	<p>● DAF</p>	<table border="1"> <tr><td>DAF-12</td><td>12</td><td>31.42[1.237]</td><td>27.94[1.100]</td></tr> <tr><td>DAFR-12</td><td>12</td><td>31.42[1.237]</td><td>27.94[1.100]</td></tr> <tr><td>DAF-10</td><td>10</td><td>26.34[1.037]</td><td>22.86[.900]</td></tr> <tr><td>DAFR-10</td><td>10</td><td>26.34[1.037]</td><td>22.86[.900]</td></tr> <tr><td>DAF-09</td><td>9</td><td>23.80[.937]</td><td>20.32[.800]</td></tr> <tr><td>DAFR-09</td><td>9</td><td>23.80[.937]</td><td>20.32[.800]</td></tr> <tr><td>DAF-08</td><td>8</td><td>21.26[.837]</td><td>17.78[.700]</td></tr> <tr><td>DAFR-08</td><td>8</td><td>21.26[.837]</td><td>17.78[.700]</td></tr> <tr><td>DAF-07</td><td>7</td><td>18.72[.737]</td><td>15.24[.600]</td></tr> <tr><td>DAFR-07</td><td>7</td><td>18.72[.737]</td><td>15.24[.600]</td></tr> <tr><td>DAF-06</td><td>6</td><td>16.18[.637]</td><td>12.70[.500]</td></tr> <tr><td>DAFR-06</td><td>6</td><td>16.18[.637]</td><td>12.70[.500]</td></tr> <tr><td>DAF-05</td><td>5</td><td>13.64[.537]</td><td>10.16[.400]</td></tr> <tr><td>DAFR-05</td><td>5</td><td>13.64[.537]</td><td>10.16[.400]</td></tr> <tr><td>DAF-04</td><td>4</td><td>11.10[.437]</td><td>7.62[.300]</td></tr> <tr><td>DAFR-04</td><td>4</td><td>11.10[.437]</td><td>7.62[.300]</td></tr> <tr><td>DAF-03</td><td>3</td><td>8.56[.337]</td><td>5.08[.200]</td></tr> <tr><td>DAFR-03</td><td>3</td><td>8.56[.337]</td><td>5.08[.200]</td></tr> <tr><td>DAF-02</td><td>2</td><td>6.02[.237]</td><td>2.54[.100]</td></tr> <tr><td>DAFR-02</td><td>2</td><td>6.02[.237]</td><td>2.54[.100]</td></tr> <tr><td>DAF-01</td><td>1</td><td>3.48[.137]</td><td>---</td></tr> <tr><td>DAFR-01</td><td>1</td><td>3.48[.137]</td><td>---</td></tr> </table>	DAF-12	12	31.42[1.237]	27.94[1.100]	DAFR-12	12	31.42[1.237]	27.94[1.100]	DAF-10	10	26.34[1.037]	22.86[.900]	DAFR-10	10	26.34[1.037]	22.86[.900]	DAF-09	9	23.80[.937]	20.32[.800]	DAFR-09	9	23.80[.937]	20.32[.800]	DAF-08	8	21.26[.837]	17.78[.700]	DAFR-08	8	21.26[.837]	17.78[.700]	DAF-07	7	18.72[.737]	15.24[.600]	DAFR-07	7	18.72[.737]	15.24[.600]	DAF-06	6	16.18[.637]	12.70[.500]	DAFR-06	6	16.18[.637]	12.70[.500]	DAF-05	5	13.64[.537]	10.16[.400]	DAFR-05	5	13.64[.537]	10.16[.400]	DAF-04	4	11.10[.437]	7.62[.300]	DAFR-04	4	11.10[.437]	7.62[.300]	DAF-03	3	8.56[.337]	5.08[.200]	DAFR-03	3	8.56[.337]	5.08[.200]	DAF-02	2	6.02[.237]	2.54[.100]	DAFR-02	2	6.02[.237]	2.54[.100]	DAF-01	1	3.48[.137]	---	DAFR-01	1	3.48[.137]	---	<table border="1"> <tr><th>PROD.NO.</th><th>NO.OF POS.</th><th>DIM.A</th><th>DIM.B</th></tr> <tr><td>DAF-12</td><td>12</td><td>31.42[1.237]</td><td>27.94[1.100]</td></tr> <tr><td>DAFR-12</td><td>12</td><td>31.42[1.237]</td><td>27.94[1.100]</td></tr> <tr><td>DAF-10</td><td>10</td><td>26.34[1.037]</td><td>22.86[.900]</td></tr> <tr><td>DAFR-10</td><td>10</td><td>26.34[1.037]</td><td>22.86[.900]</td></tr> <tr><td>DAF-09</td><td>9</td><td>23.80[.937]</td><td>20.32[.800]</td></tr> <tr><td>DAFR-09</td><td>9</td><td>23.80[.937]</td><td>20.32[.800]</td></tr> <tr><td>DAF-08</td><td>8</td><td>21.26[.837]</td><td>17.78[.700]</td></tr> <tr><td>DAFR-08</td><td>8</td><td>21.26[.837]</td><td>17.78[.700]</td></tr> <tr><td>DAF-07</td><td>7</td><td>18.72[.737]</td><td>15.24[.600]</td></tr> <tr><td>DAFR-07</td><td>7</td><td>18.72[.737]</td><td>15.24[.600]</td></tr> <tr><td>DAF-06</td><td>6</td><td>16.18[.637]</td><td>12.70[.500]</td></tr> <tr><td>DAFR-06</td><td>6</td><td>16.18[.637]</td><td>12.70[.500]</td></tr> <tr><td>DAF-05</td><td>5</td><td>13.64[.537]</td><td>10.16[.400]</td></tr> <tr><td>DAFR-05</td><td>5</td><td>13.64[.537]</td><td>10.16[.400]</td></tr> <tr><td>DAF-04</td><td>4</td><td>11.10[.437]</td><td>7.62[.300]</td></tr> <tr><td>DAFR-04</td><td>4</td><td>11.10[.437]</td><td>7.62[.300]</td></tr> <tr><td>DAF-03</td><td>3</td><td>8.56[.337]</td><td>5.08[.200]</td></tr> <tr><td>DAFR-03</td><td>3</td><td>8.56[.337]</td><td>5.08[.200]</td></tr> <tr><td>DAF-02</td><td>2</td><td>6.02[.237]</td><td>2.54[.100]</td></tr> <tr><td>DAFR-02</td><td>2</td><td>6.02[.237]</td><td>2.54[.100]</td></tr> <tr><td>DAF-01</td><td>1</td><td>3.48[.137]</td><td>---</td></tr> <tr><td>DAFR-01</td><td>1</td><td>3.48[.137]</td><td>---</td></tr> </table> <p>SCHEMATIC(TYP.)</p> <p>(1,2,3,4,5,6,7,8,9,10,12, POS AVAIL)</p> <p>P.C.B. Layout</p>	PROD.NO.	NO.OF POS.	DIM.A	DIM.B	DAF-12	12	31.42[1.237]	27.94[1.100]	DAFR-12	12	31.42[1.237]	27.94[1.100]	DAF-10	10	26.34[1.037]	22.86[.900]	DAFR-10	10	26.34[1.037]	22.86[.900]	DAF-09	9	23.80[.937]	20.32[.800]	DAFR-09	9	23.80[.937]	20.32[.800]	DAF-08	8	21.26[.837]	17.78[.700]	DAFR-08	8	21.26[.837]	17.78[.700]	DAF-07	7	18.72[.737]	15.24[.600]	DAFR-07	7	18.72[.737]	15.24[.600]	DAF-06	6	16.18[.637]	12.70[.500]	DAFR-06	6	16.18[.637]	12.70[.500]	DAF-05	5	13.64[.537]	10.16[.400]	DAFR-05	5	13.64[.537]	10.16[.400]	DAF-04	4	11.10[.437]	7.62[.300]	DAFR-04	4	11.10[.437]	7.62[.300]	DAF-03	3	8.56[.337]	5.08[.200]	DAFR-03	3	8.56[.337]	5.08[.200]	DAF-02	2	6.02[.237]	2.54[.100]	DAFR-02	2	6.02[.237]	2.54[.100]	DAF-01	1	3.48[.137]	---	DAFR-01	1	3.48[.137]	---
DAF-12	12	31.42[1.237]	27.94[1.100]																																																																																																																																																																																				
DAFR-12	12	31.42[1.237]	27.94[1.100]																																																																																																																																																																																				
DAF-10	10	26.34[1.037]	22.86[.900]																																																																																																																																																																																				
DAFR-10	10	26.34[1.037]	22.86[.900]																																																																																																																																																																																				
DAF-09	9	23.80[.937]	20.32[.800]																																																																																																																																																																																				
DAFR-09	9	23.80[.937]	20.32[.800]																																																																																																																																																																																				
DAF-08	8	21.26[.837]	17.78[.700]																																																																																																																																																																																				
DAFR-08	8	21.26[.837]	17.78[.700]																																																																																																																																																																																				
DAF-07	7	18.72[.737]	15.24[.600]																																																																																																																																																																																				
DAFR-07	7	18.72[.737]	15.24[.600]																																																																																																																																																																																				
DAF-06	6	16.18[.637]	12.70[.500]																																																																																																																																																																																				
DAFR-06	6	16.18[.637]	12.70[.500]																																																																																																																																																																																				
DAF-05	5	13.64[.537]	10.16[.400]																																																																																																																																																																																				
DAFR-05	5	13.64[.537]	10.16[.400]																																																																																																																																																																																				
DAF-04	4	11.10[.437]	7.62[.300]																																																																																																																																																																																				
DAFR-04	4	11.10[.437]	7.62[.300]																																																																																																																																																																																				
DAF-03	3	8.56[.337]	5.08[.200]																																																																																																																																																																																				
DAFR-03	3	8.56[.337]	5.08[.200]																																																																																																																																																																																				
DAF-02	2	6.02[.237]	2.54[.100]																																																																																																																																																																																				
DAFR-02	2	6.02[.237]	2.54[.100]																																																																																																																																																																																				
DAF-01	1	3.48[.137]	---																																																																																																																																																																																				
DAFR-01	1	3.48[.137]	---																																																																																																																																																																																				
PROD.NO.	NO.OF POS.	DIM.A	DIM.B																																																																																																																																																																																				
DAF-12	12	31.42[1.237]	27.94[1.100]																																																																																																																																																																																				
DAFR-12	12	31.42[1.237]	27.94[1.100]																																																																																																																																																																																				
DAF-10	10	26.34[1.037]	22.86[.900]																																																																																																																																																																																				
DAFR-10	10	26.34[1.037]	22.86[.900]																																																																																																																																																																																				
DAF-09	9	23.80[.937]	20.32[.800]																																																																																																																																																																																				
DAFR-09	9	23.80[.937]	20.32[.800]																																																																																																																																																																																				
DAF-08	8	21.26[.837]	17.78[.700]																																																																																																																																																																																				
DAFR-08	8	21.26[.837]	17.78[.700]																																																																																																																																																																																				
DAF-07	7	18.72[.737]	15.24[.600]																																																																																																																																																																																				
DAFR-07	7	18.72[.737]	15.24[.600]																																																																																																																																																																																				
DAF-06	6	16.18[.637]	12.70[.500]																																																																																																																																																																																				
DAFR-06	6	16.18[.637]	12.70[.500]																																																																																																																																																																																				
DAF-05	5	13.64[.537]	10.16[.400]																																																																																																																																																																																				
DAFR-05	5	13.64[.537]	10.16[.400]																																																																																																																																																																																				
DAF-04	4	11.10[.437]	7.62[.300]																																																																																																																																																																																				
DAFR-04	4	11.10[.437]	7.62[.300]																																																																																																																																																																																				
DAF-03	3	8.56[.337]	5.08[.200]																																																																																																																																																																																				
DAFR-03	3	8.56[.337]	5.08[.200]																																																																																																																																																																																				
DAF-02	2	6.02[.237]	2.54[.100]																																																																																																																																																																																				
DAFR-02	2	6.02[.237]	2.54[.100]																																																																																																																																																																																				
DAF-01	1	3.48[.137]	---																																																																																																																																																																																				
DAFR-01	1	3.48[.137]	---																																																																																																																																																																																				

DIP SWITCH

DIP SERIES

New Piano Type

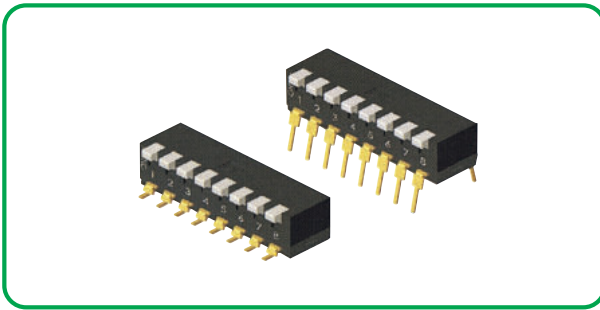

HOW TO ORDER

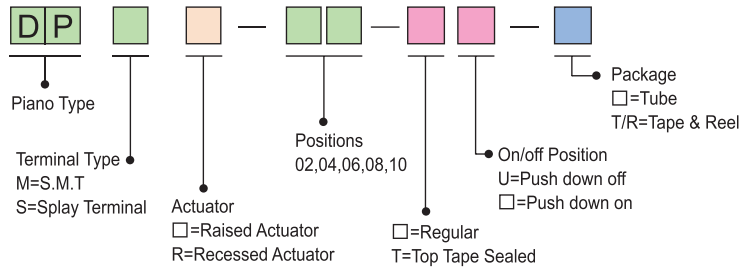

Specification

Items		Standard	Package DPS(R)/DPM(R)-02:70pcs/tube DPS(R)/DPM(R)-04:40pcs/tube DPS(R)/DPM(R)-06:28pcs/tube DPS(R)/DPM(R)-08:20pcs/tube DPS(R)/DPM(R)-10:16pcs/tube DPS(R)-02,04,06,08,10:700pcs/reel
Environmental	Operation Temperature Range	-20°C to +85°C	
	Storage Temperature Range	-40°C to +85°C	
Electrical performance	Electrical Life	2,000 operations	
	Non-Switching Rating	100mA,50VDC	
	Switching Rating	25mA,24VDC	
Mechanical performance	Operating force	800gf max.	

Diagram

No.	Dimensions	Circuit Diagram Pad Layout			
		DPS-10	DPS-08	DPS-06	DPS-04
1	<p>● DPS</p>	10	8	6	4
		26.8[1.055]	21.72[.855]	16.64[.655]	11.56[.455]
		22.86[.900]	17.78[.700]	12.70[.500]	7.62[.300]
		6.48[.255]	2.54[.100]	SCHEMATIC (TYP.)	
		PROD.NO.	NO.OF POS.	DIM.A	DIM.B
		<p>Circuit Diagram</p> <p>P.C.B. Layout</p>			

DIP SERIES

New Piano Type



Diagram

No.	Dimensions	Circuit Diagram Pad Layout																							
		Circuit Diagram Pad Layout																							
2	<p>● DPM</p>	<table border="1"> <tr> <td>DPM-10</td> <td>10</td> <td>26.8[1.055]</td> <td>22.86[.900]</td> </tr> <tr> <td>DPM-08</td> <td>8</td> <td>21.72[.855]</td> <td>17.78[.700]</td> </tr> <tr> <td>DPM-06</td> <td>6</td> <td>16.64[.655]</td> <td>12.70[.500]</td> </tr> <tr> <td>DPM-04</td> <td>4</td> <td>11.56[.455]</td> <td>7.62[.300]</td> </tr> <tr> <td>DPM-02</td> <td>2</td> <td>6.48[.255]</td> <td>2.54[.100]</td> </tr> </table>	DPM-10	10	26.8[1.055]	22.86[.900]	DPM-08	8	21.72[.855]	17.78[.700]	DPM-06	6	16.64[.655]	12.70[.500]	DPM-04	4	11.56[.455]	7.62[.300]	DPM-02	2	6.48[.255]	2.54[.100]			
		DPM-10	10	26.8[1.055]	22.86[.900]																				
DPM-08	8	21.72[.855]	17.78[.700]																						
DPM-06	6	16.64[.655]	12.70[.500]																						
DPM-04	4	11.56[.455]	7.62[.300]																						
DPM-02	2	6.48[.255]	2.54[.100]																						
		<table border="1"> <thead> <tr> <th>PROD.NO.</th> <th>NO. OF POS.</th> <th>DIM.A</th> <th>DIM.B</th> </tr> </thead> <tbody> <tr> <td colspan="4">SCHEMATIC(TYP.)</td> </tr> <tr> <td colspan="4"> <p>Circuit Diagram</p> </td> </tr> </tbody> </table> <p>P.C.B. Layout</p>				PROD.NO.	NO. OF POS.	DIM.A	DIM.B	SCHEMATIC(TYP.)				<p>Circuit Diagram</p>											
PROD.NO.	NO. OF POS.	DIM.A	DIM.B																						
SCHEMATIC(TYP.)																									
<p>Circuit Diagram</p>																									

DIP SERIES

End Stackable Piano Type

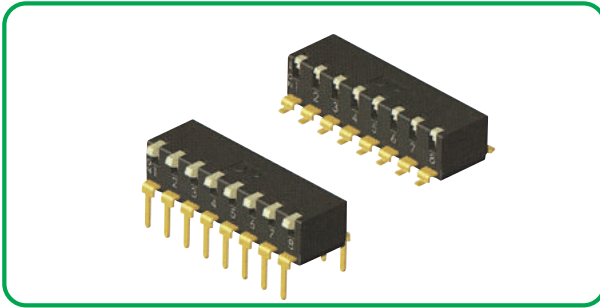

HOW TO ORDER

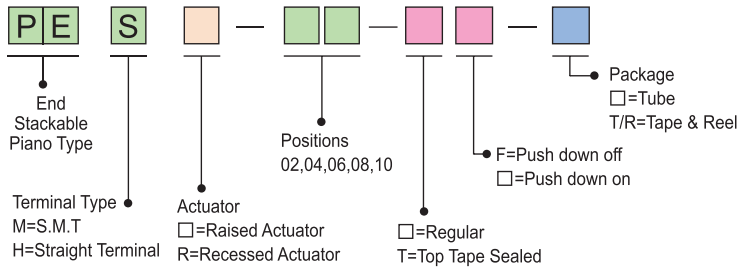

Specification

Items		Standard	Package
Environmental	Operation Temperature Range	-20°C to +85°C	
	Storage Temperature Range	-40°C to +85°C	
Electrical performance	Electrical Life	2,000 cycles	
	Switching Rating	25mA,24VDC	
Mechanical performance	Operating force	800gf max.	

Diagram

No.	Dimensions	Circuit Diagram																											
		Pad Layout																											
1	● PEH 	<table border="1"> <tr> <td>PEH-10 PEHR-10</td> <td>10</td> <td>25.30[.996]</td> <td>22.86[.900]</td> </tr> <tr> <td>PEH-08 PEHR-08</td> <td>8</td> <td>20.22[.796]</td> <td>17.78[.700]</td> </tr> <tr> <td>PEH-06 PEHR-06</td> <td>6</td> <td>15.14[.596]</td> <td>12.70[.500]</td> </tr> <tr> <td>PEH-04 PEHR-04</td> <td>4</td> <td>10.06[.396]</td> <td>7.62[.300]</td> </tr> <tr> <td>PEH-02 PEHR-02</td> <td>2</td> <td>4.89[.196]</td> <td>2.54[.100]</td> </tr> <tr> <td>PROD.NO.</td> <td>NO.OF POS.</td> <td>DIM.A</td> <td>DIM.B</td> </tr> </table>	PEH-10 PEHR-10	10	25.30[.996]	22.86[.900]	PEH-08 PEHR-08	8	20.22[.796]	17.78[.700]	PEH-06 PEHR-06	6	15.14[.596]	12.70[.500]	PEH-04 PEHR-04	4	10.06[.396]	7.62[.300]	PEH-02 PEHR-02	2	4.89[.196]	2.54[.100]	PROD.NO.	NO.OF POS.	DIM.A	DIM.B	SCHEMATIC(TYP.) (2,4,6,8,10 POS AVAIL)		
		PEH-10 PEHR-10	10	25.30[.996]	22.86[.900]																								
PEH-08 PEHR-08	8	20.22[.796]	17.78[.700]																										
PEH-06 PEHR-06	6	15.14[.596]	12.70[.500]																										
PEH-04 PEHR-04	4	10.06[.396]	7.62[.300]																										
PEH-02 PEHR-02	2	4.89[.196]	2.54[.100]																										
PROD.NO.	NO.OF POS.	DIM.A	DIM.B																										
P.C.B. Layout																													

DIP SWITCH

DIP SERIES

End Stackable Piano Type



Diagram

No.	Dimensions	Circuit Diagram Pad Layout			
		PROD.NO.	NO. OF POS.	DIM.A	DIM.B
2	<p>● PEM</p>	PEM-10 PEMR-10	10	25.30[.996]	22.86[.900]
		PEM-08 PEMR-08	8	20.22[.796]	17.78[.700]
		PEM-06 PEMR-06	6	15.14[.596]	12.70[.500]
		PEM-04 PEMR-04	4	10.06[.396]	7.62[.300]
		PEM-02 PEMR-02	2	4.89[.196]	2.54[.100]
		<p>SCHMATIC(TYP.)</p> <p>(2,4,6,8,10 POS AVAIL)</p>			
		<p>$B=2.54x(P-1)$ $[B=.100x(P-1)]$</p> <p>P.C.B. Layout</p>			

DIP SERIES

Slide Type Dip Switch

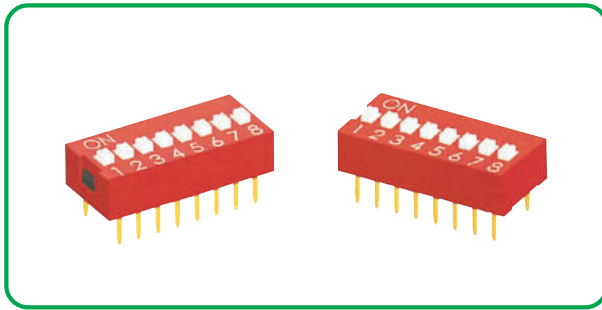

HOW TO ORDER

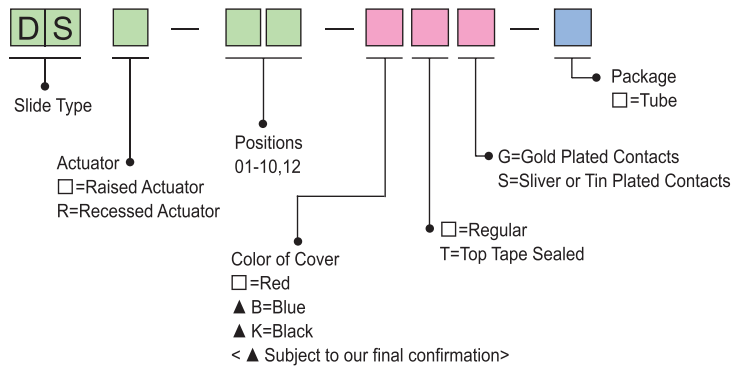

Specification

Items		Standard	Package
Environmental	Operation Temperature Range	-20°C to +70°C	DS(R)-01:120pcs/tube DS(R)-01-T:113pcs/tube
	Storage Temperature Range	-40°C to +85°C	DS(R)-02:72pcs/tube DS(R)-02-T:70pcs/tube
Electrical performance	Electrical Life	2,000 operations	DS(R)-03:51pcs/tube DS(R)-03-T:50pcs/tube
	Non-Switching Rating	100mA,50VDC	DS(R)-04:40pcs/tube DS(R)-04-T:39pcs/tube
	Switching Rating	25mA,24VDC	DS(R)-05:32pcs/tube DS(R)-05-T:32pcs/tube
Mechanical performance	Operating force	1,000gf max.	DS(R)-06:27pcs/tube DS(R)-06-T:27pcs/tube
	Stroke	2.0mm	DS(R)-07:24pcs/tube DS(R)-07-T:24pcs/tube
			DS(R)-08:21pcs/tube DS(R)-08-T:21pcs/tube
			DS(R)-09:19pcs/tube DS(R)-09-T:19pcs/tube
			DS(R)-10:17pcs/tube DS(R)-10-T:17pcs/tube
			DS(R)-12:14pcs/tube DS(R)-12-T:14pcs/tube

Diagram

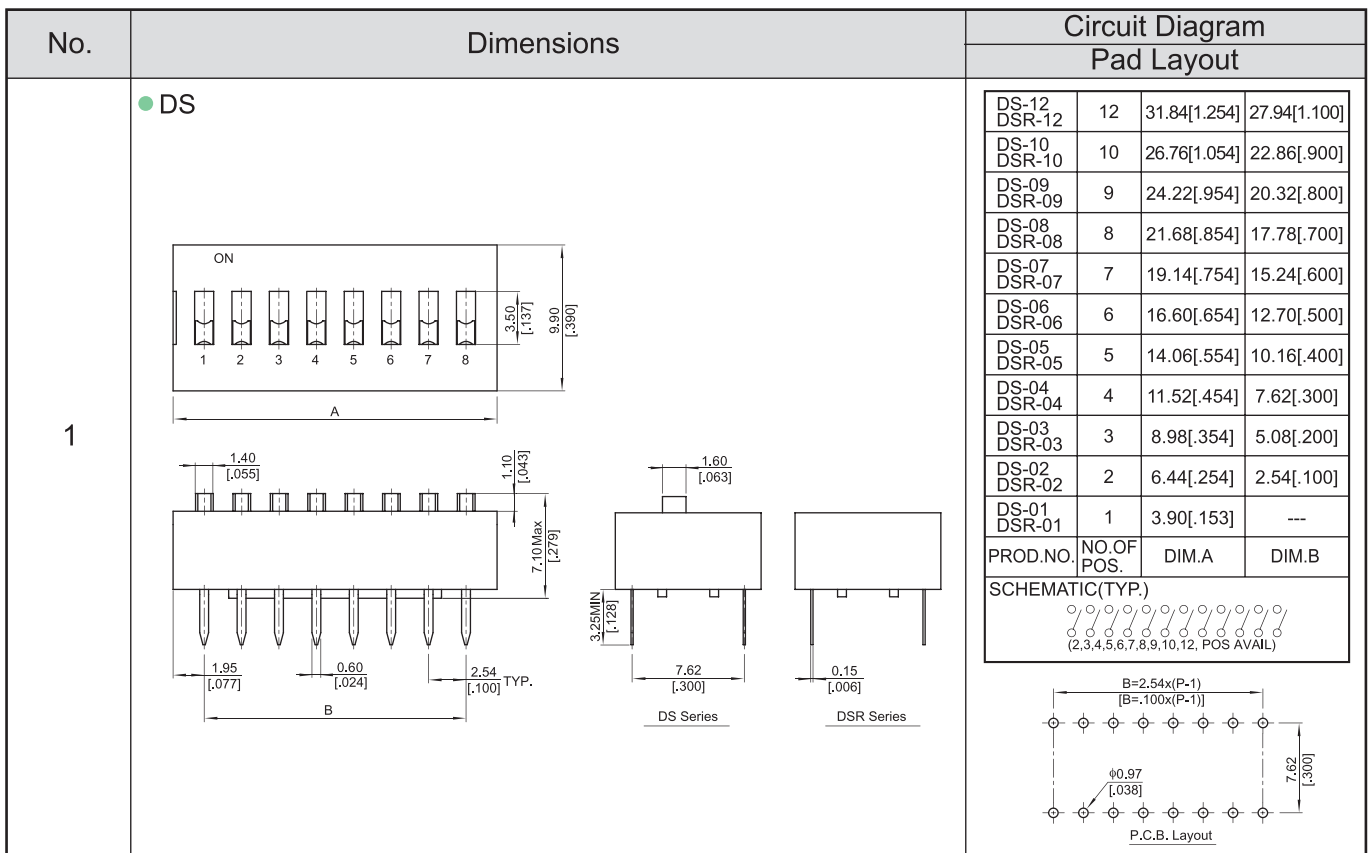

DIP SWITCH

DIP SERIES

Piano Type Dip Switch

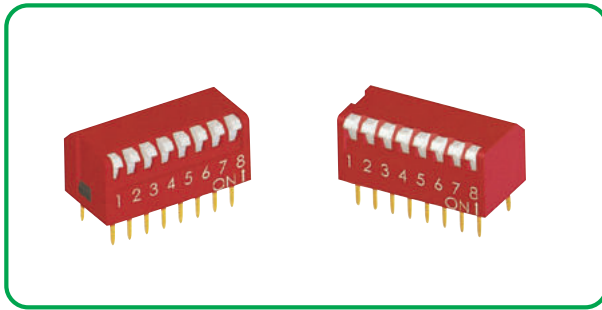

HOW TO ORDER

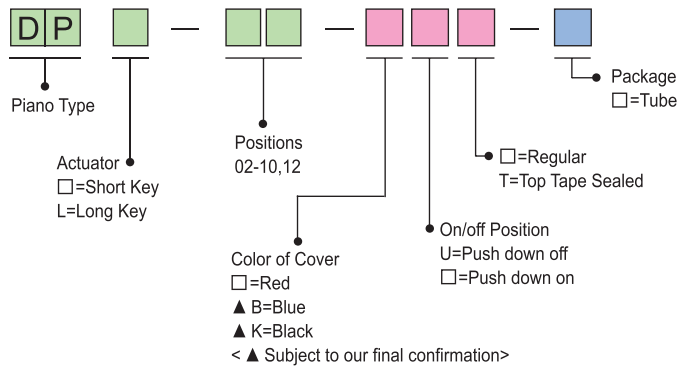

Specification

Items		Standard	Package	
Environmental	Operation Temperature Range	-20 °C to +70 °C	DP(L)-02:70pcs/tube	DP(L)-02-T:75pcs/tube
	Storage Temperature Range	-40 °C to +85 °C	DP(L)-03:50pcs/tube	DP(L)-03-T:49pcs/tube
Electrical performance	Electrical Life	2,000 operations	DP(L)-04:39pcs/tube	DP(L)-04-T:39pcs/tube
	Non-Switching Rating	100mA,50VDC	DP(L)-05:32pcs/tube	DP(L)-05-T:32pcs/tube
	Switching Rating	25mA,24VDC	DP(L)-06:27pcs/tube	DP(L)-06-T:27pcs/tube
Mechanical performance	Operating force	400gf max.	DP(L)-07:24pcs/tube	DP(L)-07-T:24pcs/tube
	Stroke	2.0mm	DP(L)-08:21pcs/tube	DP(L)-08-T:21pcs/tube
			DP(L)-09:19pcs/tube	DP(L)-09-T:19pcs/tube
			DP(L)-10:17pcs/tube	DP(L)-10-T:17pcs/tube
			DP(L)-12:14pcs/tube	DP(L)-12-T:14pcs/tube

Diagram

No.	Dimensions	Circuit Diagram																																													
		Pad Layout																																													
1	<p>● DP</p>	<table border="1"> <tr> <td>DP-12 DPL-12</td> <td>12</td> <td>31.84[1.254]</td> <td>27.94[1.100]</td> </tr> <tr> <td>DP-10 DPL-10</td> <td>10</td> <td>26.76[1.054]</td> <td>22.86[.900]</td> </tr> <tr> <td>DP-09 DPL-09</td> <td>9</td> <td>24.22[.954]</td> <td>20.32[.800]</td> </tr> <tr> <td>DP-08 DPL-08</td> <td>8</td> <td>21.68[.854]</td> <td>17.78[.700]</td> </tr> <tr> <td>DP-07 DPL-07</td> <td>7</td> <td>19.14[.754]</td> <td>15.24[.600]</td> </tr> <tr> <td>DP-06 DPL-06</td> <td>6</td> <td>16.60[.654]</td> <td>12.70[.500]</td> </tr> <tr> <td>DP-05 DPL-05</td> <td>5</td> <td>14.06[.554]</td> <td>10.16[.400]</td> </tr> <tr> <td>DP-04 DPL-04</td> <td>4</td> <td>11.52[.454]</td> <td>7.62[.300]</td> </tr> <tr> <td>DP-03 DPL-03</td> <td>3</td> <td>8.98[.354]</td> <td>5.08[.200]</td> </tr> <tr> <td>DP-02 DPL-02</td> <td>2</td> <td>6.44[.261]</td> <td>2.54[.100]</td> </tr> </table>	DP-12 DPL-12	12	31.84[1.254]	27.94[1.100]	DP-10 DPL-10	10	26.76[1.054]	22.86[.900]	DP-09 DPL-09	9	24.22[.954]	20.32[.800]	DP-08 DPL-08	8	21.68[.854]	17.78[.700]	DP-07 DPL-07	7	19.14[.754]	15.24[.600]	DP-06 DPL-06	6	16.60[.654]	12.70[.500]	DP-05 DPL-05	5	14.06[.554]	10.16[.400]	DP-04 DPL-04	4	11.52[.454]	7.62[.300]	DP-03 DPL-03	3	8.98[.354]	5.08[.200]	DP-02 DPL-02	2	6.44[.261]	2.54[.100]	<table border="1"> <tr> <th>PROD.NO.</th> <th>NO.OF POS.</th> <th>DIM.A</th> <th>DIM.B</th> </tr> </table> <p>SCHEMATIC(TYP.)</p> <p>(2,3,4,5,6,7,8,9,10,12, POS AVAIL)</p> <p>P.C.B. Layout</p>	PROD.NO.	NO.OF POS.	DIM.A	DIM.B
		DP-12 DPL-12	12	31.84[1.254]	27.94[1.100]																																										
DP-10 DPL-10	10	26.76[1.054]	22.86[.900]																																												
DP-09 DPL-09	9	24.22[.954]	20.32[.800]																																												
DP-08 DPL-08	8	21.68[.854]	17.78[.700]																																												
DP-07 DPL-07	7	19.14[.754]	15.24[.600]																																												
DP-06 DPL-06	6	16.60[.654]	12.70[.500]																																												
DP-05 DPL-05	5	14.06[.554]	10.16[.400]																																												
DP-04 DPL-04	4	11.52[.454]	7.62[.300]																																												
DP-03 DPL-03	3	8.98[.354]	5.08[.200]																																												
DP-02 DPL-02	2	6.44[.261]	2.54[.100]																																												
PROD.NO.	NO.OF POS.	DIM.A	DIM.B																																												

DIP SWITCH

DIP SERIES

Right Angle Type Dip Switch

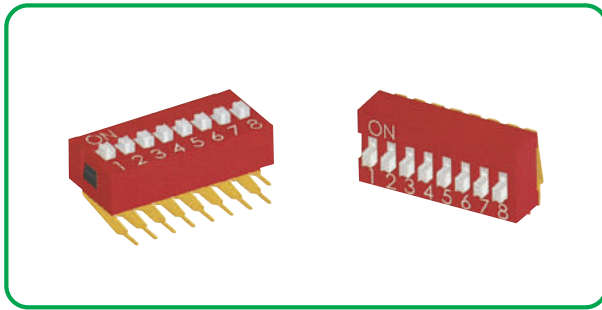

HOW TO ORDER

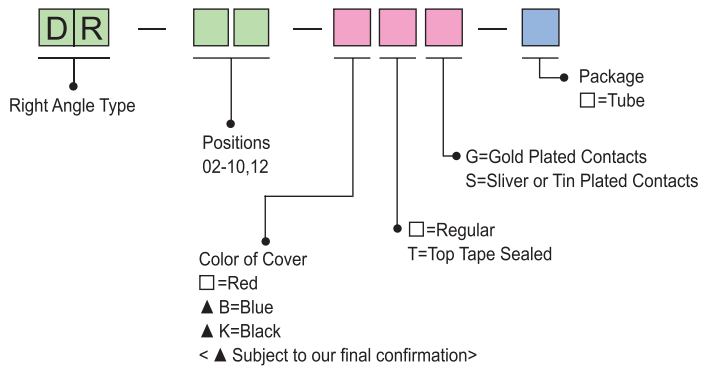

Specification

Items		Standard	Package	
Environmental	Operation Temperature Range	-20 °C to +70 °C	DR-02:73pcs/tube	DA-02-T:70pcs/tube
	Storage Temperature Range	-40 °C to +85 °C	DR-03:52pcs/tube	DA-03-T:50pcs/tube
Electrical performance	Electrical Life	2,000 operations	DR-04:40pcs/tube	DA-04-T:39pcs/tube
	Non-Switching Rating	100mA,50VDC	DR-05:33pcs/tube	DA-05-T:32pcs/tube
	Switching Rating	25mA,24VDC	DR-06:28pcs/tube	DA-06-T:28pcs/tube
Mechanical performance	Operating force	1,000gf max.	DR-07:24pcs/tube	DA-07-T:24pcs/tube
	Stroke	2.0mm	DR-08:21pcs/tube	DA-08-T:21pcs/tube
			DR-09:19pcs/tube	DA-09-T:19pcs/tube
			DR-10:17pcs/tube	DA-10-T:17pcs/tube
			DR-12:14pcs/tube	DA-12-T:14pcs/tube

Diagram

No.	Dimensions	Circuit Diagram																																									
		Pad Layout																																									
1	<p>● DR</p>	<table border="1"> <thead> <tr> <th>DR-12</th> <th>12</th> <th>31.84[1.254]</th> <th>27.94[1.100]</th> </tr> </thead> <tbody> <tr> <td>DR-10</td> <td>10</td> <td>26.76[1.054]</td> <td>22.86[.900]</td> </tr> <tr> <td>DR-09</td> <td>9</td> <td>24.22[.954]</td> <td>20.32[.800]</td> </tr> <tr> <td>DR-08</td> <td>8</td> <td>21.68[.854]</td> <td>17.78[.700]</td> </tr> <tr> <td>DR-07</td> <td>7</td> <td>19.14[.754]</td> <td>15.24[.600]</td> </tr> <tr> <td>DR-06</td> <td>6</td> <td>16.60[.654]</td> <td>12.70[.500]</td> </tr> <tr> <td>DR-05</td> <td>5</td> <td>14.06[.554]</td> <td>10.16[.400]</td> </tr> <tr> <td>DR-04</td> <td>4</td> <td>11.52[.454]</td> <td>7.62[.300]</td> </tr> <tr> <td>DR-03</td> <td>3</td> <td>8.98[.354]</td> <td>5.08[.200]</td> </tr> <tr> <td>DR-02</td> <td>2</td> <td>6.44[.261]</td> <td>2.54[.100]</td> </tr> </tbody> </table>		DR-12	12	31.84[1.254]	27.94[1.100]	DR-10	10	26.76[1.054]	22.86[.900]	DR-09	9	24.22[.954]	20.32[.800]	DR-08	8	21.68[.854]	17.78[.700]	DR-07	7	19.14[.754]	15.24[.600]	DR-06	6	16.60[.654]	12.70[.500]	DR-05	5	14.06[.554]	10.16[.400]	DR-04	4	11.52[.454]	7.62[.300]	DR-03	3	8.98[.354]	5.08[.200]	DR-02	2	6.44[.261]	2.54[.100]
		DR-12	12	31.84[1.254]	27.94[1.100]																																						
DR-10	10	26.76[1.054]	22.86[.900]																																								
DR-09	9	24.22[.954]	20.32[.800]																																								
DR-08	8	21.68[.854]	17.78[.700]																																								
DR-07	7	19.14[.754]	15.24[.600]																																								
DR-06	6	16.60[.654]	12.70[.500]																																								
DR-05	5	14.06[.554]	10.16[.400]																																								
DR-04	4	11.52[.454]	7.62[.300]																																								
DR-03	3	8.98[.354]	5.08[.200]																																								
DR-02	2	6.44[.261]	2.54[.100]																																								
<p>SCHEMATIC(TYP.)</p>																																											

DIP SWITCH

TERMINAL TYPE

■ When order tact switch, please refer to the following illustration for your terminal choice

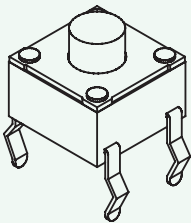
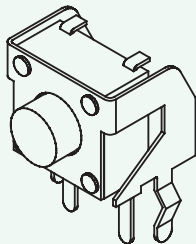
Vertical	Horizontal
	

■ Terminal Type

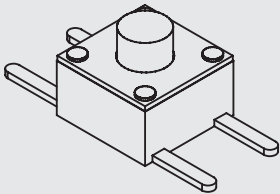
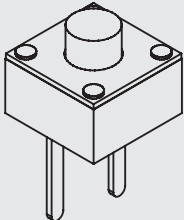
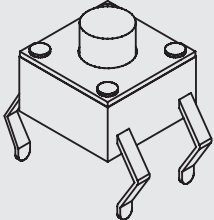
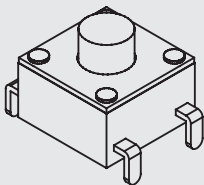
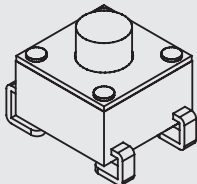
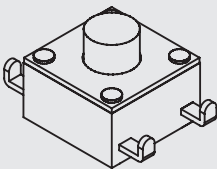
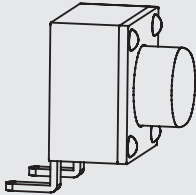
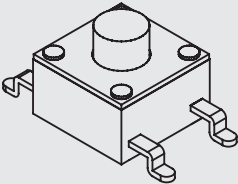
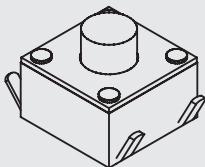
 <p data-bbox="244 1244 450 1274">F: Flat Terminal</p>	 <p data-bbox="703 1244 836 1274">T: Tapping</p>	 <p data-bbox="1038 1244 1390 1274">P: Through Hole Terminals</p>
 <p data-bbox="288 1597 395 1627">J: J type</p>	 <p data-bbox="699 1597 810 1627">J: J type</p>	 <p data-bbox="1129 1597 1353 1627">R: Reverse Lead</p>
 <p data-bbox="277 1957 405 1987">M: S.M.T</p>	 <p data-bbox="703 1957 831 1987">M: S.M.T</p>	 <p data-bbox="1166 1957 1283 1987">U:U type</p>

CAUTION

Caution

1. Note that terminals might suffer deformation of the switch and the defects in electrical performance, if the load is applied to the terminals during soldering.
2. If you use a through-hole PC board or a PC board thinner or thicker than the recommendation, there may be greater heat stress. Verify the soldering conditions thoroughly before use.
3. When soldering twice, wait until the first soldered portion cools to normal temperature. Continuous heating will deform the external portions, loosen or dislodge terminals, or may deteriorate their electrical characteristics.
4. Verify soldering conditions under actual mass production conditions.
5. This product is designed and manufactured assuming that it is to be used with the resistance for direct current. If you use other kinds of resistance [inductive (L) or capacitive (C)], consult with us beforehand.
6. For the sizes of holes and patterns on a PC board for mounting a switch, refer to the recommended dimensions in the outline drawings.
7. This switch is designed for manually operated units. Do not use this switch in a mechanical detection unit. For detection purposes, please use our detection switch.
8. The switch will break if you apply a greater stress than that specified. Take great care not to let the switch be subject to greater stress than specified.
9. Do not press the side of the stem.
10. Be sure to push the center position of a flat stem switch. Extreme care is required for a hinge structure type because the stem press position moves when it is pressed.
11. If you put the board with the switch in the oven so as to harden adhesive for other parts, consult with us.
12. When corrosive gas is generated by a peripheral material of a product using the TACT switch, malfunctions such as imperfect contacts can occur. Check this point thoroughly in advance.
13. The contact resistance of a rubber contact type changes depending on pressure load. Confirm that it functions sufficiently when you use this TACT switch with a voltage divider circuit.
14. Be aware of dust intrusion into an unsealed-type TACT switch.
15. Storage method
 - (1) If you do not use the product immediately, store it just as delivered in the following environment: with neither direct sunshine nor corrosive gas and in normal temperatures. However, it is recommended that you should use it as soon as possible or within six months from the date of delivery at the most.
 - (2) After you break the seal, you should put the remainder in a plastic bag to shut out outside air, and store it in the same environment mentioned above. You should use it up as soon as possible.
 - (3) Do not stack too many switches for safety.
 - (4) Store the key switches with the switch in the released position.

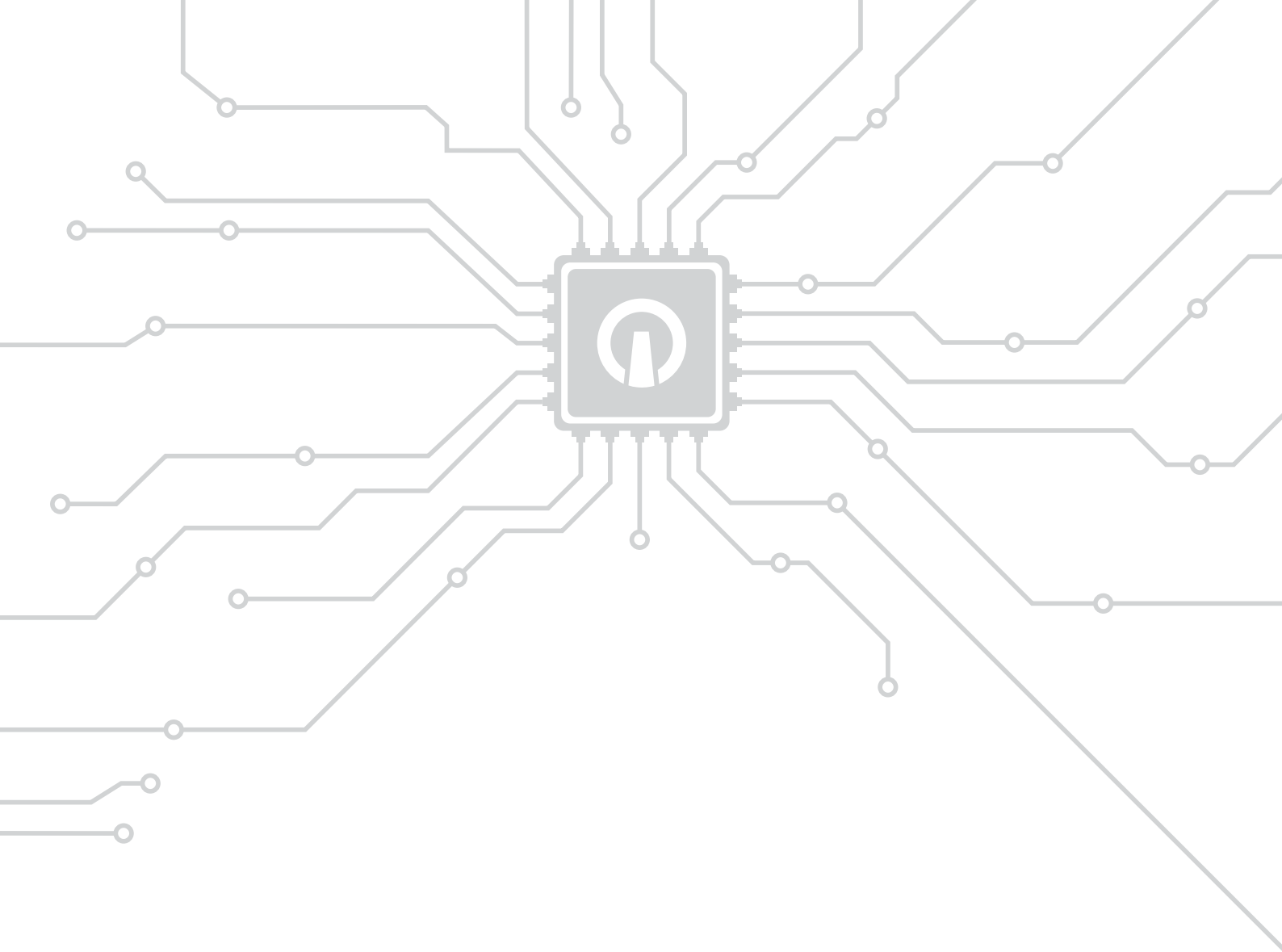

InterElcom Sp. z o.o.

ul. Zagony 25, 54-614 Wrocław, Polska

NIP: 8982185866, Regon: 021451864

T: +48 (71) 780 78 36 | F: +48 (71) 780 78 46

www.interelcom.com | info@interelcom.com